

# **AN–1133 LM2653EVAL 1.5A Synchronous Switching Regulator Evaluation Board**

---

---

---

## **1 Introduction**

The LM2653 switching regulator provides high efficiency power conversion over a 100:1 load range (1.5A to 15 mA). This feature makes the LM2653 an ideal fit in battery-powered applications.

Synchronous rectification and 75 mΩ internal switches provide up to 97% efficiency. At light loads, the LM2653 enters a low power hysteretic or “sleep” mode to keep the efficiency high. In many applications, the efficiency still exceeds 80% at 15 mA load. A shutdown pin is available to disable the LM2653 and reduce the supply current to 7 μA.

The IC contains patented current sensing circuitry for current mode control. This feature eliminates the external current sensing required by other current-mode DC-DC converters.

The IC has a 300kHz fixed frequency internal oscillator. The high oscillator frequency allows the use of extremely small, low profile components.

The evaluation board can be obtained by ordering part number LM2653EVAL from your local Texas Instruments sales office, or TI's website at <http://www.ti.com>.

## **2 Evaluation Board Design**

The evaluation board is designed to supply 2.5 V at up to 1.5A. The input voltage range is 4 V to 14 V. Components were selected based on the design procedure in the *LM2653 1.5A High Efficiency Synchronous Switching Regulator Data Sheet* ([SNVS050](#)). The feedback resistors can be adjusted to achieve a different output voltage:

$$V_{OUT} = 1.238 \text{ V} \times [1 + (R_1/R_2)] \quad (1)$$

Choose 1% resistors between 10 kΩ to 100 kΩ for R1 and R2.

PCB layout is critical to reduce noises and ensure specified performance. For layout guidelines, see the *LM2653 1.5A High Efficiency Synchronous Switching Regulator Data Sheet* ([SNVS050](#)). The artwork for the evaluation board is shown at the end of this application report.

The schematic for the evaluation board is shown in [Figure 1](#), and the parts list is given in [Table 1](#).

When the undervoltage protection occurs, the output voltage can be pulled below ground as the inductor current is reversed through the synchronous FET. For applications that need to be protected from a negative voltage, a clamping diode D2 is recommended.

The PGOOD flag goes low whenever the overvoltage or undervoltage latch protection is enabled. The overvoltage protection will be enabled immediately when the output voltage exceeds 110% of its nominal. While the undervoltage latch protection will wait for a period of time set by the LDELAY capacitor. If the output voltage is still below 80% of its nominal after this waiting period, the latch protection will be enabled.

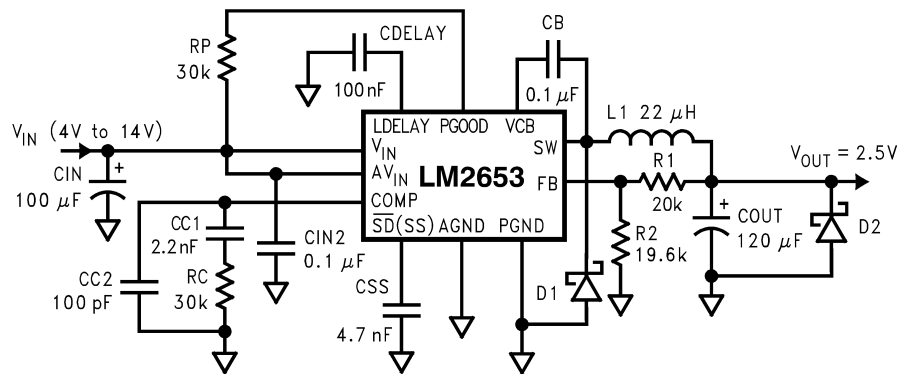
**Figure 1. LM2653 EVAL Schematic**
**Table 1. Parts List (Bill Of Materials)**

Designation	Description
L1	22 µH, Coilcraft DO3316P-223
CIN (input capacitor)	100 µF, 16 V, Sprague 594D107X0016D2T
CIN2 (input capacitor)	0.1 µF ceramic capacitor
CB (bootstrap capacitor)	0.1 µF ceramic capacitor
CSS (softstart capacitor)	4.7 nF ceramic capacitor
COUT (output capacitor)	120 µF, 6.3 V, Sprague 594D127X06R3C2T
CC1 (compensation)	2.2 nF ceramic capacitor
CC2 (compensation)	100 pF ceramic capacitor
RC (compensation)	30 kΩ, 5% resistor
D1	1A Schottky diode, Motorola MBRA130LT3
R1	20.0k, 1% resistor
R2	19.6k, 1% resistor
CDELAY	100 nF ceramic capacitor
RP	50K, 5% resistor
D2	Open

### 3 Typical PC Board Layout: (2X Size)

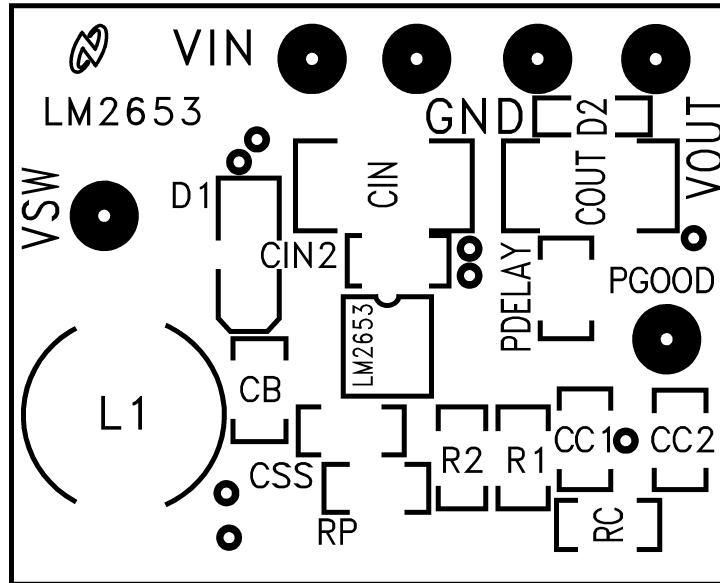

Figure 2. Component Placement Guide

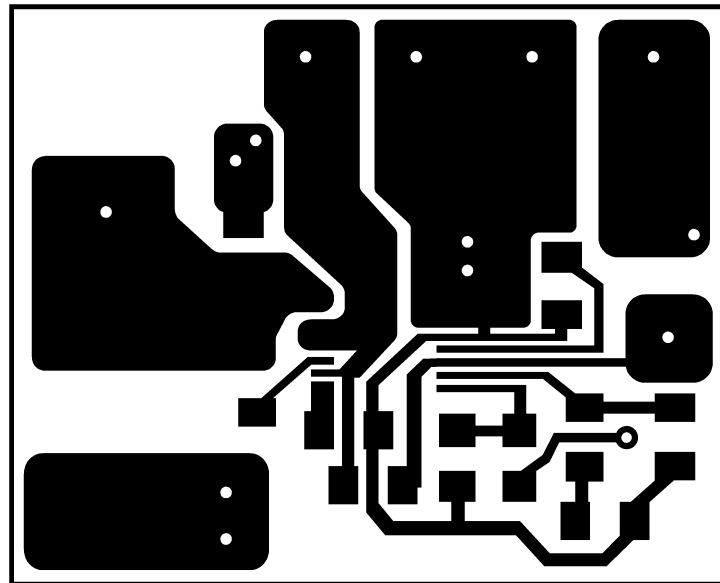

Figure 3. Component Side PC Board Layout

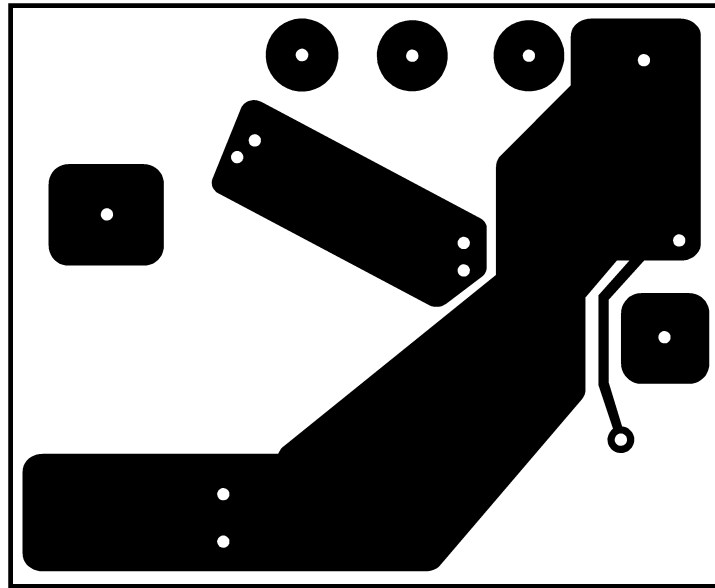

Figure 4. Solder Side PC Board Layout

#### 4 References

*LM2653 1.5A High Efficiency Synchronous Switching Regulator Data Sheet* ([SNVS050](#))

## IMPORTANT NOTICE

Texas Instruments Incorporated and its subsidiaries (TI) reserve the right to make corrections, enhancements, improvements and other changes to its semiconductor products and services per JESD46, latest issue, and to discontinue any product or service per JESD48, latest issue. Buyers should obtain the latest relevant information before placing orders and should verify that such information is current and complete. All semiconductor products (also referred to herein as "components") are sold subject to TI's terms and conditions of sale supplied at the time of order acknowledgment.

TI warrants performance of its components to the specifications applicable at the time of sale, in accordance with the warranty in TI's terms and conditions of sale of semiconductor products. Testing and other quality control techniques are used to the extent TI deems necessary to support this warranty. Except where mandated by applicable law, testing of all parameters of each component is not necessarily performed.

TI assumes no liability for applications assistance or the design of Buyers' products. Buyers are responsible for their products and applications using TI components. To minimize the risks associated with Buyers' products and applications, Buyers should provide adequate design and operating safeguards.

TI does not warrant or represent that any license, either express or implied, is granted under any patent right, copyright, mask work right, or other intellectual property right relating to any combination, machine, or process in which TI components or services are used. Information published by TI regarding third-party products or services does not constitute a license to use such products or services or a warranty or endorsement thereof. Use of such information may require a license from a third party under the patents or other intellectual property of the third party, or a license from TI under the patents or other intellectual property of TI.

Reproduction of significant portions of TI information in TI data books or data sheets is permissible only if reproduction is without alteration and is accompanied by all associated warranties, conditions, limitations, and notices. TI is not responsible or liable for such altered documentation. Information of third parties may be subject to additional restrictions.

Resale of TI components or services with statements different from or beyond the parameters stated by TI for that component or service voids all express and any implied warranties for the associated TI component or service and is an unfair and deceptive business practice. TI is not responsible or liable for any such statements.

Buyer acknowledges and agrees that it is solely responsible for compliance with all legal, regulatory and safety-related requirements concerning its products, and any use of TI components in its applications, notwithstanding any applications-related information or support that may be provided by TI. Buyer represents and agrees that it has all the necessary expertise to create and implement safeguards which anticipate dangerous consequences of failures, monitor failures and their consequences, lessen the likelihood of failures that might cause harm and take appropriate remedial actions. Buyer will fully indemnify TI and its representatives against any damages arising out of the use of any TI components in safety-critical applications.

In some cases, TI components may be promoted specifically to facilitate safety-related applications. With such components, TI's goal is to help enable customers to design and create their own end-product solutions that meet applicable functional safety standards and requirements. Nonetheless, such components are subject to these terms.

No TI components are authorized for use in FDA Class III (or similar life-critical medical equipment) unless authorized officers of the parties have executed a special agreement specifically governing such use.

Only those TI components which TI has specifically designated as military grade or "enhanced plastic" are designed and intended for use in military/aerospace applications or environments. Buyer acknowledges and agrees that any military or aerospace use of TI components which have **not** been so designated is solely at the Buyer's risk, and that Buyer is solely responsible for compliance with all legal and regulatory requirements in connection with such use.

TI has specifically designated certain components as meeting ISO/TS16949 requirements, mainly for automotive use. In any case of use of non-designated products, TI will not be responsible for any failure to meet ISO/TS16949.

### Products

Audio	<a href="http://www.ti.com/audio">www.ti.com/audio</a>
Amplifiers	<a href="http://amplifier.ti.com">amplifier.ti.com</a>
Data Converters	<a href="http://dataconverter.ti.com">dataconverter.ti.com</a>
DLP® Products	<a href="http://www.dlp.com">www.dlp.com</a>
DSP	<a href="http://dsp.ti.com">dsp.ti.com</a>
Clocks and Timers	<a href="http://www.ti.com/clocks">www.ti.com/clocks</a>
Interface	<a href="http://interface.ti.com">interface.ti.com</a>
Logic	<a href="http://logic.ti.com">logic.ti.com</a>
Power Mgmt	<a href="http://power.ti.com">power.ti.com</a>
Microcontrollers	<a href="http://microcontroller.ti.com">microcontroller.ti.com</a>
RFID	<a href="http://www.ti-rfid.com">www.ti-rfid.com</a>
OMAP Applications Processors	<a href="http://www.ti.com/omap">www.ti.com/omap</a>
Wireless Connectivity	<a href="http://www.ti.com/wirelessconnectivity">www.ti.com/wirelessconnectivity</a>

### Applications

Automotive and Transportation	<a href="http://www.ti.com/automotive">www.ti.com/automotive</a>
Communications and Telecom	<a href="http://www.ti.com/communications">www.ti.com/communications</a>
Computers and Peripherals	<a href="http://www.ti.com/computers">www.ti.com/computers</a>
Consumer Electronics	<a href="http://www.ti.com/consumer-apps">www.ti.com/consumer-apps</a>
Energy and Lighting	<a href="http://www.ti.com/energy">www.ti.com/energy</a>
Industrial	<a href="http://www.ti.com/industrial">www.ti.com/industrial</a>
Medical	<a href="http://www.ti.com/medical">www.ti.com/medical</a>
Security	<a href="http://www.ti.com/security">www.ti.com/security</a>
Space, Avionics and Defense	<a href="http://www.ti.com/space-avionics-defense">www.ti.com/space-avionics-defense</a>
Video and Imaging	<a href="http://www.ti.com/video">www.ti.com/video</a>

### TI E2E Community

[e2e.ti.com](http://e2e.ti.com)