

DESCRIPTION

The IF-E92A and IF-E92B are blue LEDs housed in a “connector-less” style plastic fiber optic package. The IF-E92A contains a Silicon Carbide die with a spectral output peaking at 430 nm and the IF-E92B die is made from Gallium Nitride peaking at 470 nm. The device package features an internal micro-lens and a precision-molded PBT housing to ensure efficient optical coupling with standard 1000 μm core plastic fiber cable.

APPLICATION HIGHLIGHTS

These LEDs are low-cost alternatives to other light sources for producing a narrowband blue light output that can be efficiently coupled into a fiber cable. They can be used in a variety of sensor and display applications that require a narrowband optical light source whose intensity can be easily adjusted or modulated without changing optical spectrum. When combined with red and green LEDs the IF-E92A and IF-E92B provide an RGB source for generating white or multicolored light. Applications include process control for color identification/separation and demonstration of wavelength division multiplexing for educational purposes. The IF-E92A and IF-E92B are also capable of digital data rates of 1 Mbps and 800 kbps respectively. The electrical drive circuit design is the same as that of other LEDs, making the IF-E92A and IF-E92B cost-effective light sources in a variety of analog, digital sensor and lighting applications.

APPLICATIONS

- Optical Sensors
- RGB Light Sources
- Color Separation for Process Control
- Medical Instruments
- Analog and Digital Data Links
- Robotics Communications
- Display Indicators
- Electronic Games
- Wavelength Multiplexing
- Fluorescent Instruments

FEATURES

- ◆ Easily Adjusted or Modulated Blue Optical Output
- ◆ Fast Transition Times
- ◆ No Optical Design Required
- ◆ Mates With Standard 1000 μm Core Jacketed Plastic Fiber Cable
- ◆ Internal Micro-Lens for Efficient Optical Coupling
- ◆ Inexpensive Plastic Connector Housing
- ◆ Connector-Less Fiber Termination
- ◆ RoHS Compliant

MAXIMUM RATINGS

(T_A=25°C)

Operating and Storage Temperature Range (T_{OP}, T_{STG})-40° to 60°C
 Junction Temperature (T_J)85°C
 Soldering Temperature (2 mm from case bottom) (T_S) t ≤ 5s240°C
 Reverse Voltage (V_R).....5 V
 Power Dissipation (P_{TOT}) T_A=25°C.....60 mW
 De-rate Above 25°C....1.1 mW/°C
 Forward Current, DC (I_F) ...35 mA
 Surge Current (I_{FSM}) t ≤ 10 μs75 mA

CHARACTERISTICS (T_A =25°C)

Parameter Typical Values	Symbol	IF-E92A	IF-E92B	Unit
Peak Wavelength	λ _{PEAK}	430	470	nm
Spectral Bandwidth (50% of I _{MAX})	Δλ	65	25	nm
Output Power Coupled into Plastic Fiber (1 mm core diameter). Distance Lens to Fiber ≤ 0.1 mm, 10 cm polished fiber, I _F =10 mA	Φ _{min}	25 -16	75 -11	μW dBm
Switching Times (10% to 90% and 90% to 10%) (R _L =47Ω, I _F =10 mA)	t _r , t _f	.5	.6	ns
Capacitance (V _F =0, F=1 Mhz)	C ₀	100	100	pF
Forward Voltage (I _F =20 mA)	V _f	4.5 max	4.0 max	V
Temperature Coefficient, λ _{PEAK}	TC _λ	.16	.16	nm/K

CAUTION: The IF E92 is ESD sensitive. To minimize risk of damage observe appropriate precautions during handling and processing.

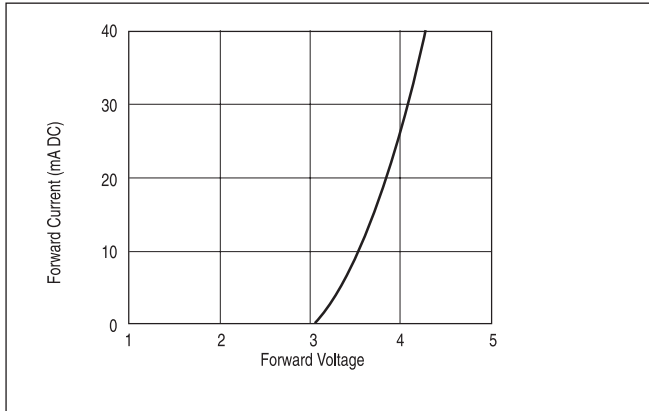

FIGURE 1. Forward current versus forward voltage.

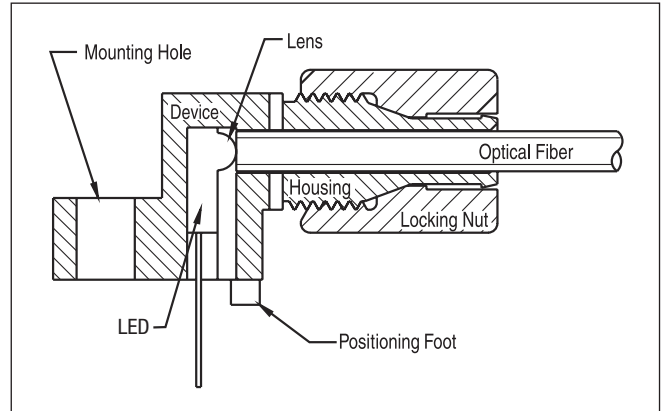

FIGURE 3. Cross-section of fiber optic device.

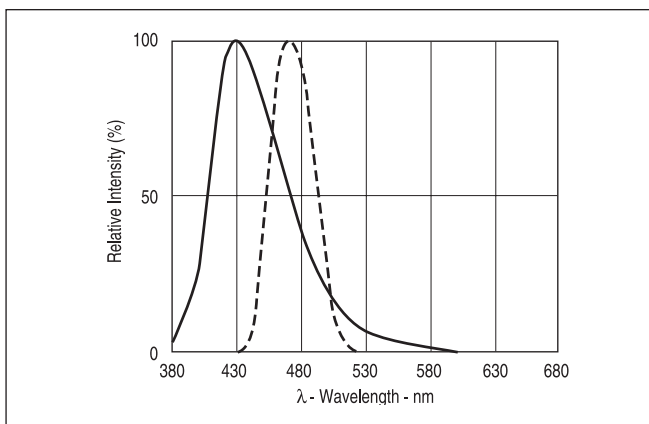

FIGURE 2. Typical spectral output vs. wavelength.

FIBER TERMINATION INSTRUCTIONS

1. Cut off the ends of the optical fiber with a single-edge razor blade or sharp knife. Try to obtain a precise 90-degree angle (square).
2. Insert the fiber through the locking nut and into the connector until the core tip seats against the internal micro-lens.
3. Screw the connector locking nut down to a snug fit, locking the fiber in place.

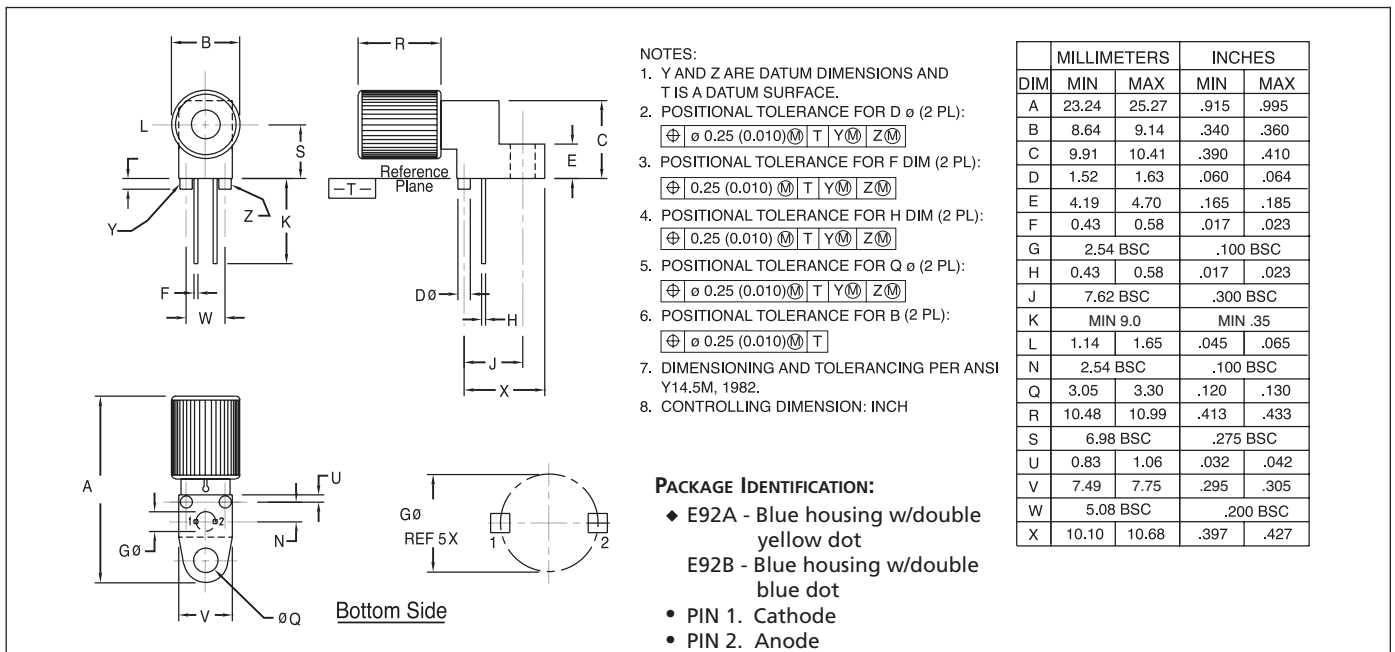

FIGURE 4. Case outline. Specifications are believed to be accurate but are subject to change. Industrial Fiber Optics assumes no responsibility for the consequences of using the information provided beyond replacement warranty for products not meeting stated specifications. Industrial Fiber Optics products are not authorized for use in life support applications without written approval from the President of Industrial Fiber Optics Corporation.

NOTE: • To avoid degraded device life due to package stress, do not bend or form leads outside the orientation shown on drawing.
 • To avoid degrading the performance, it is recommended to not wave solder or wash the device.