

DESCRIPTION

The IF-D98 is a very high-speed photologic detector housed in a “connector-less” style plastic fiber optic package. The detector contains an IC with a photodiode, linear amplifier and Schmitt trigger featuring an ACT logic compatible totem-pole output. Optical response of the IF-D98 extends from 400 to 1050 nm, making it compatible with a wide range of LED and laser diode sources. The detector package features an internal micro-lens, and a precision-molded PBT housing ensures efficient optical coupling with standard 1000 μm core plastic fiber cable.

APPLICATION HIGHLIGHTS

The fast transition times of the IF-D98 make it suitable for high-speed digital data links. Link distances in excess of 75 meters at data rates of 155 Mbps are possible using standard 1000 μm core plastic fiber and an IF-E99 LED. The integrated design of the IF-D98 provides simple, cost-effective implementation in a variety of digital applications.

APPLICATIONS

- ▶ PC-to-Peripheral Data Links
- ▶ Motor Controller Triggering
- ▶ Ethernet LANs
- ▶ Medical Instruments
- ▶ Automotive Electronics
- ▶ Digitized Video and HDTV
- ▶ Sonet/SDH Receivers
- ▶ Robotics Communications
- ▶ Isolation from Lightning and Voltage Transients

FEATURES

- ◆ No Optical Design Required
- ◆ Mates with Standard 1000 μm Core Jacketed Plastic Fiber Cable
- ◆ Internal Micro-Lens for Efficient Coupling
- ◆ Inexpensive Plastic Connector Housing
- ◆ Connector-Less Fiber Termination and Connection
- ◆ Interference-Free Transmission from Light-Tight Housing
- ◆ Totem-Pole Output

MAXIMUM RATINGS

(T_A =25°C)

Operating Temperature Range
(T_{OP})-20° to 70°C

Storage Temperature Range
(T_{STG})-40° to 85°C

Soldering Temperature
(2mm from case bottom)
(T_S) t ≤ 5 s.....240°C

Supply Voltage, (V_S)..... -5 to 7 V

Power Dissipation
(P_{TOT}) T_A=25°C250 mW

De-rate Above 25°C1.7 mW/°C

CHARACTERISTICS (T_A =25°C)

Parameter	Symbol	Min.	Typ.	Max.	Unit
Peak Sensitivity	λ _{PEAK}	-	800	-	nm
Spectral Bandwidth (S=10% of S _{MAX})	Δλ	400	-	1050	nm
Operating Voltage	V _{CC}	4.75	5	5.25	V
Supply Current	I _{CC}	-	-	40	mA
Light Required to Trigger ^{1, 2, 3, 4, 5} (V _{CC} =5 V, λ=660 nm)	E _r (+)	-	6.3 -22	-	μW dBm
High Level Output Voltage ^{1, 2, 5} (I _{OH} = -1 mA)	V _{OH}	3.9	-	4.3	V
Low Level Output Voltage ^{1, 2, 5} (I _{OH} = -0.5 mA)	V _{OL}	2.9	-	3.4	V
Output Rise and Fall Times ^{1, 2, 5}	t _r , t _f	-	-	3	ns
Data Rate ^{6, 7}	f _D	4	-	156	Mbps
Pulse Width Distortion	Δt	-3	-	3	ns
Jitter	Δt _j	-	-	3	ns

NOTES:

1. Input signal at 156 Mbps (Bi-phase signal)

2. 3 pF capacitor as load (including parasitic capacitance such as probes, connectors, and PCB patterns)

3. Optical input waveform is generated with IF-E99 LED

4. Average value, measured using plastic fiber (MH4001 by Mitsubishi Rayon)

5. 3 kΩ resistor externally connected to Q and Q̄

6. Bi-phase signal; NRZ conversion

7. No transition with DC light, no light, and modulated light below 4 Mbps

CAUTION: The IF D98 is ESD sensitive. To minimize risk of damage observe appropriate precautions during handling and processing.

IF D98 Plastic Fiber Optic 155 Mbps Photologic Detector

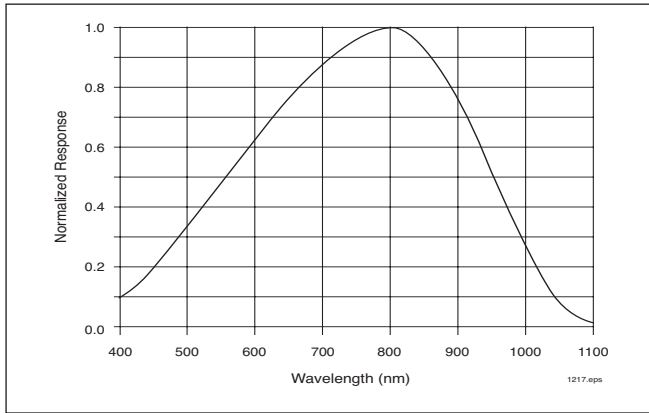

FIGURE 1. Normalized detector response versus wavelength.

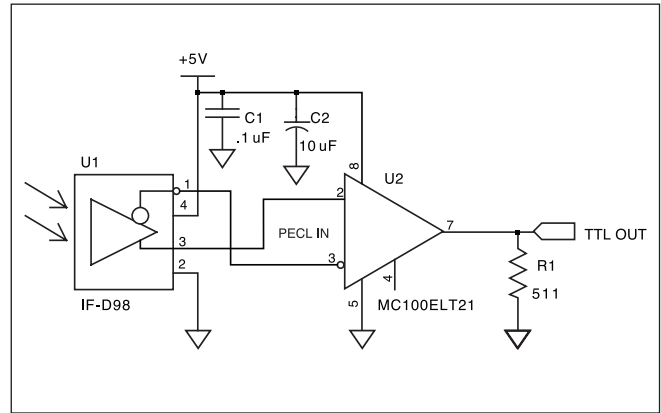

FIGURE 3. Typical interface circuit.

FIBER TERMINATION INSTRUCTIONS

1. Cut off the ends of the optical fiber with a single-edge razor blade or sharp knife. Try to obtain a precise 90-degree angle (square).
2. Insert the fiber through the locking nut and into the connector until the core tip seats against the internal micro-lens.
3. Screw the connector locking nut down to a snug fit, locking the fiber in place.

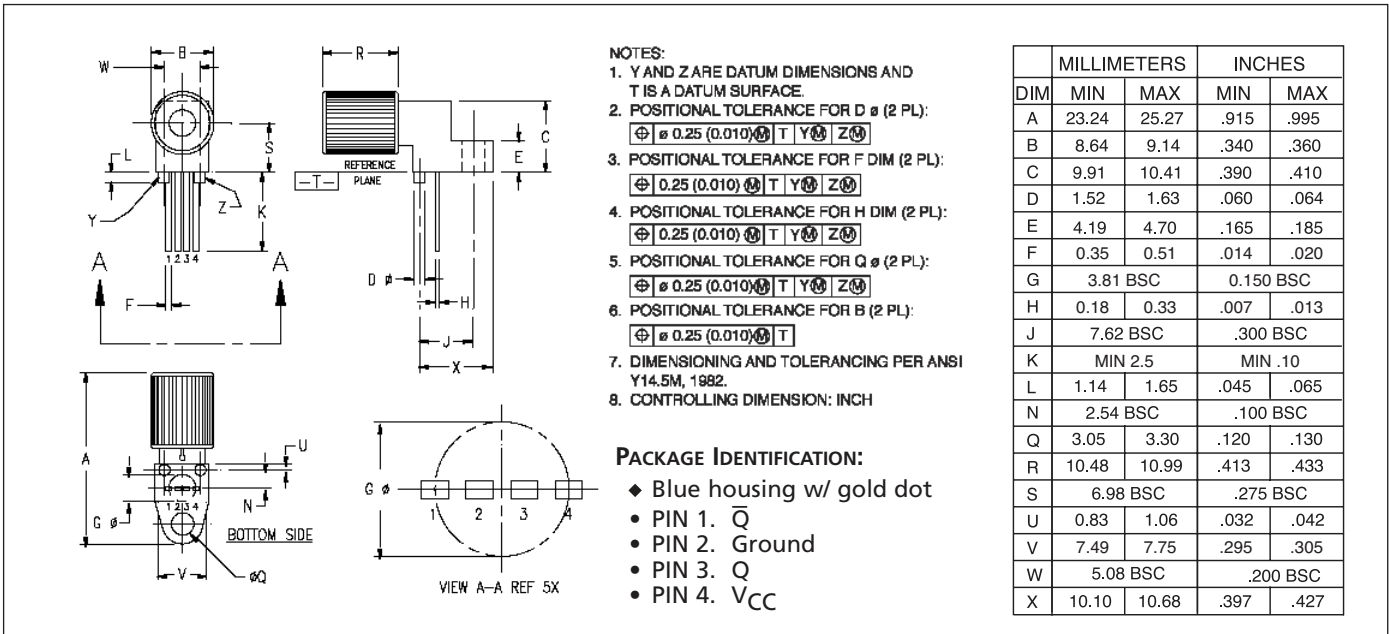

FIGURE 4. Case outline. Specifications are believed to be accurate but are subject to change. Industrial Fiber Optics assumes no responsibility for the consequences of using the information provided beyond replacement warranty for products not meeting stated specifications. Industrial Fiber Optics products are not authorized for use in life support applications without written approval from the President of Industrial Fiber Optics Corporation.

NOTE: • To avoid degraded device life due to package stress, do not bend or form leads outside the orientation shown on drawing.
• To avoid degrading the performance, it is recommended to not wave solder or wash the device.