

Plastic Fiber Optic Photologic Detectors IF D95

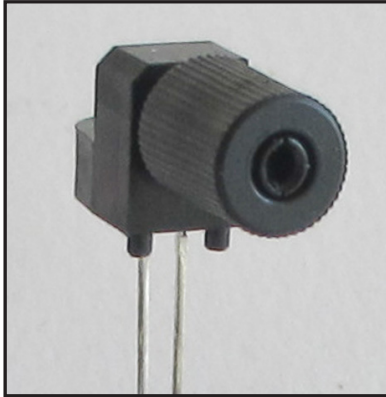

DESCRIPTION

The IF-D95T and IF-D95OC are high-sensitivity photologic detectors housed in “connector-less” style plastic fiber optic packages. The detector contains an IC with a photodiode, linear amplifier, and Schmitt trigger logic circuit. The IF-D95T features a TTL/CMOS compatible totem-pole output, while the IF-D95OC has an open-collector output. The devices can drive up to 5 TTL loads over supply voltages ranging from 4.5 to 16 Volts. Optical response extends from 400 to 1100 nm, making them compatible with a wide range of visible and near infrared LED and laser diode sources. The detector package features an internal micro-lens and a precision-molded PBT housing to ensure efficient optical coupling with standard 1000 μm core plastic fiber cable.

APPLICATION HIGHLIGHTS

The IF-D95T and IF-D95OC are suitable for digital data links at rates up to 125 kbps. A Schmitt trigger improves noise immunity and TTL/CMOS logic compatibility greatly simplifies interfacing with existing digital circuits. The integrated design of the IF-D95 provides a total, cost-effective solution in a variety of digital applications.

APPLICATIONS

- Digital Data Links
- PC-to-Peripheral Links
- Process Control
- Household Appliances
- Motor Controller Triggering
- Electronic Games
- Medical Instruments
- Automotive Electronics
- Robotics Communications
- EMC/EMI Signal Isolation

FEATURES

- ◆ Integrated Photodetector, Amplifier and Schmitt Trigger
- ◆ Mates with Standard 1000 μm Core Jacketed Plastic Fiber Optic Cable
- ◆ No Optical Design Required
- ◆ Inexpensive But Rugged Plastic Connector Housing
- ◆ Internal Micro-Lens for Efficient Optical Coupling
- ◆ Connector-Less Fiber Termination
- ◆ Light-Tight Housing Provides Interference-Free Transmission
- ◆ High Optical Sensitivity
- ◆ “Active Low” Output Options Available as Special Order
- ◆ RoHS Compliant

MAXIMUM RATINGS

(T_A =25°C)
 Operating and Storage Temperature Range (T_{OP}, T_{STG}).....-40°to 85°C
 Soldering Temperature (2mm from case bottom) (T_S) t ≤ 5 s.....240°C
 Supply Voltage, (V_S)16 V
 Voltage at Output lead (IF-95OC only)30 V
 Sinking Current, DC (I_C)50 mA
 Source Current (I_O) (IF-95T only)10 mA
 Power Dissipation (P_{TOT}) T_A=25°C100 mW
 De-rate Above 25°2.50 mW/°C

CHARACTERISTICS (T_A =25°C)

Parameter	Symbol	Min.	Typ.	Max.	Unit
Peak Sensitivity	λ _{PEAK}	-	800	-	nm
Spectral Sensitivity (S=10% of S _{MAX})	Δλ	400	-	1100	nm
Operating Voltage	V _{CC}	4.5	-	16	V
Supply Current	I _{CC}	-	-	6	mA
Light Required to Trigger V _{CC} =5 V, R _L =1k, λ=660 nm	E _r (+)	-	1.0 (-30)	-	μW/(dBm)
IF-D95T					
High Level Output Voltage (I _{OH} = -1.0 μA)	V _{OH}	V _{CC} -2.1	-	-	V
Low Level Output Voltage (I _{OH} = 16 mA)	V _{OL}	-	-	0.34	V
Output Rise and Fall Times (f= 10.0 kHz, R _L = 10 TTL Loads)	t _r , t _f	-	-	70	ns
Propagation Delay, Low-High, High-Low (f= 10.0 kHz, R _L = 10 TTL Loads)	t _{PLH} , t _{PHL}	-	8.0	-	μs
IF-D95OC					
High Level Output Current (V _{OH} =30 V)	I _{OH}	-	-	100	μA
Low Level Output Voltage (I _{OL} =16 mA)	I _{OL}	-	-	0.4	V
Output Rise and Fall Times (f= 10.0 kHz, R _L =360Ω)	t _r , t _f	-	-	100	ns
Propagation Delay, Low-High, High-Low (f= 10.0 kHz, R _L =360Ω)	t _{PLH} , t _{PHL}	-	6.0	-	μs

CAUTION: The IF D95 is ESD sensitive. To minimize risk of damage observe appropriate precautions during handling and processing.

IF D95 Plastic Fiber Optic Photologic Detectors

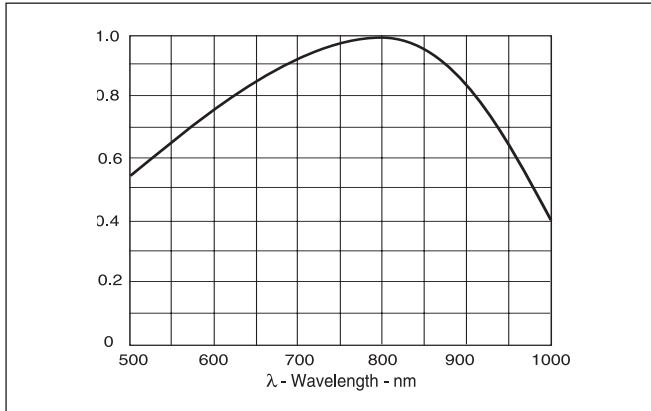

FIGURE 1. Normalized detector response versus wavelength.

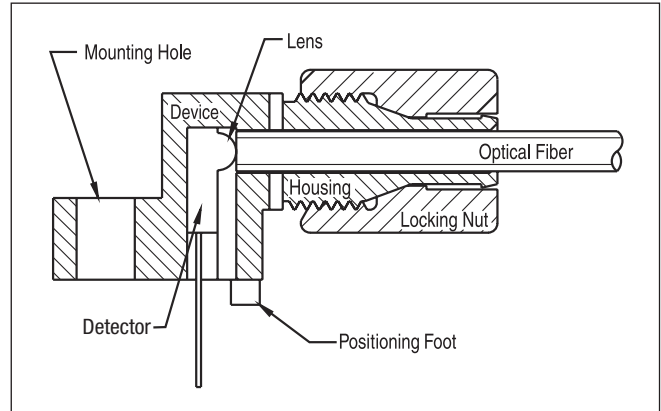

FIGURE 3. Cross-section of fiber optic device.

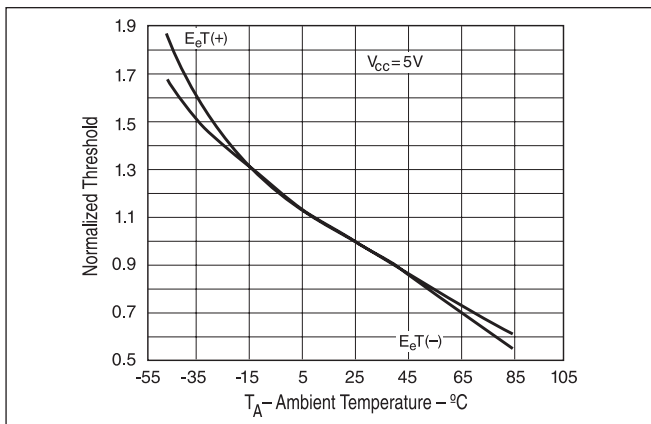

FIGURE 2. Normalized threshold irradiance vs. amb. temp.

FIBER TERMINATION INSTRUCTIONS

1. Cut off the ends of the optical fiber with a single-edge razor blade or sharp knife. Try to obtain a precise 90-degree angle (square).
2. Insert the fiber through the locking nut and into the connector until the core tip seats against the internal micro-lens.
3. Screw the connector locking nut down to a snug fit, locking the fiber in place.

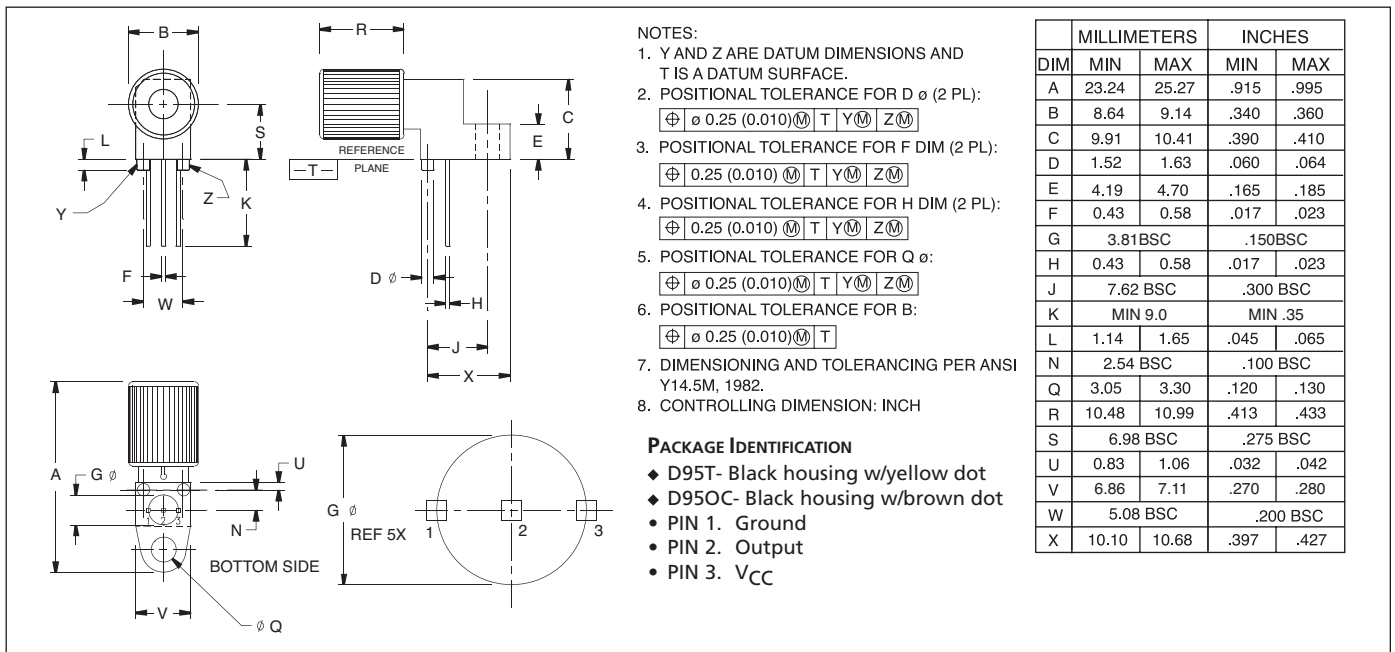

FIGURE 4. Case outline. Specifications are believed to be accurate but are subject to change. Industrial Fiber Optics assumes no responsibility for the consequences of using the information provided beyond replacement warranty for products not meeting stated specifications. Industrial Fiber Optics products are not authorized for use in life support applications without written approval from the President of Industrial Fiber Optics Corporation.

- NOTE:
- To avoid degraded device life due to package stress, do not bend or form leads outside the orientation shown on drawing.
 - To avoid degrading the performance, it is recommended to not wave solder or wash the device.