

## APPLICATIONS

- Low-Speed Optical Links
- Optical Interrupter/ Reflective Sensors
- Process Control
- Motor Controller Triggering
- Medical Instruments
- Automotive Electronics
- Robotics Control
- EMC/EMI Signal Isolation
- Electronic Games

## DESCRIPTION

The IF-D93 is a very high-sensitivity photodarlington detector housed in a “connector-less” style plastic fiber optic package. Optical response of the IF-D93 extends from 400 to 1100 nm, making it compatible with a wide range of visible and near-infrared LEDs and other optical sources. This includes 650 nm visible red LEDs used for optimum transmission in PMMA plastic optic fiber. The detector package features an internal micro-lens and a precision-molded PBT housing to ensure efficient optical coupling with standard 1000 μm core plastic fiber cable.

## APPLICATION HIGHLIGHTS

The IF-D93 is suitable for low-speed optical links requiring high sensitivity. Triggering rates up to 1 kHz are possible using the IF-D93 and a suitable LED source. Photodarlington transistor operation provides very high optical gain, eliminating the need for post amplification in many circuits. The integrated design of the IF-D93 makes it a simple, cost-effective solution in a variety of applications.

## FEATURES

- ◆ Mates with Standard 1000 μm Core Jacketed Plastic Fiber Optic Cable
- ◆ No Optical Design Required
- ◆ Inexpensive but Rugged Plastic Connector Housing
- ◆ Internal Micro-Lens for Efficient Optical Coupling
- ◆ Connector-Less Fiber Termination
- ◆ Light-Tight Housing provides Interference Free-Transmission
- ◆ Very High Optical Sensitivity
- ◆ RoHS Compliant

## MAXIMUM RATINGS

( $T_A = 25^\circ\text{C}$ )  
 Operating and Storage Temperature Range  
 ( $T_{OP}, T_{STG}$ )..... $-40^\circ$  to  $85^\circ\text{C}$   
 Junction Temperature ( $T_J$ )..... $85^\circ\text{C}$   
 Soldering Temperature  
 (2mm from case bottom)  
 ( $T_S$ )  $t \leq 5$  s..... $240^\circ\text{C}$   
 Collector Emitter Voltage  
 ( $V_{CEO}$ ).....15 V  
 Emitter Collector Voltage  
 ( $V_{ECO}$ ) .....5 V  
 Collector Current ( $I_C$ ).....50mA  
 Collector Peak Current  
 ( $I_{CM}$ )  $t = 1$  ms .....100 mA  
 Power Dissipation  
 ( $P_{TOT}$ )  $T_A = 25^\circ\text{C}$ .....100 mW  
 De-rate Above  $25^\circ\text{C}$ .....1.33 mW/ $^\circ\text{C}$

## CHARACTERISTICS ( $T_A = 25^\circ\text{C}$ )

Parameter	Symbol	Min.	Typ.	Max.	Unit
Wavelength for Maximum Photosensitivity	$\lambda_{PEAK}$	-	850	-	nm
Spectral Bandwidth (S=10% of SMAX)	$\Delta\lambda$	400	-	1100	nm
Switching Times (10% to 90% and 90% to 10%) (RL=1kΩ, VCE=5 V, λ=880 nm) See Figure 2.	$t_r, t_f$	-	5, 2.5	-	ms
Responsivity min. @ 880 nm @ 632 nm	R	- -	400 200	- -	$\mu\text{A}/\mu\text{W}$ $\mu\text{A}/\mu\text{W}$
Collector Dark Current (VCE=15 volts)	$I_{CEO}$	-	-	100	nA
Breakdown Voltage ( $I_C=1$ mA)	$BV_{CEO}$	15	-	-	V
Breakdown Voltage ( $I_C=100$ μA)	$BV_{ECO}$	5	-	-	V
Saturation Voltage ( $I_C=0.4$ μA, H=10 μW)	$V_{EC sat}$	-	1.10	-	V

**CAUTION:** The IF D93 is ESD sensitive. To minimize risk of damage observe appropriate precautions during handling and processing.

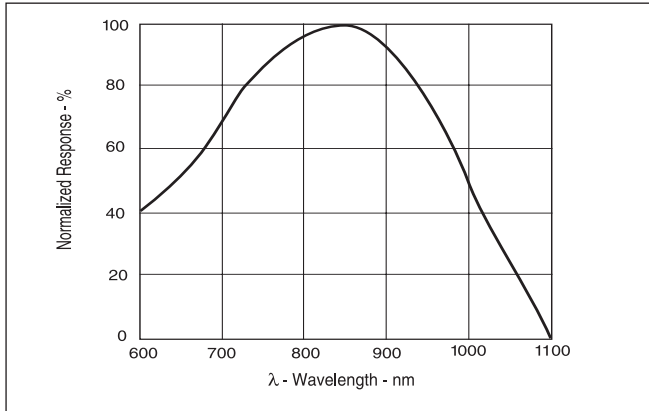

FIGURE 1. Typical detector response versus wavelength.

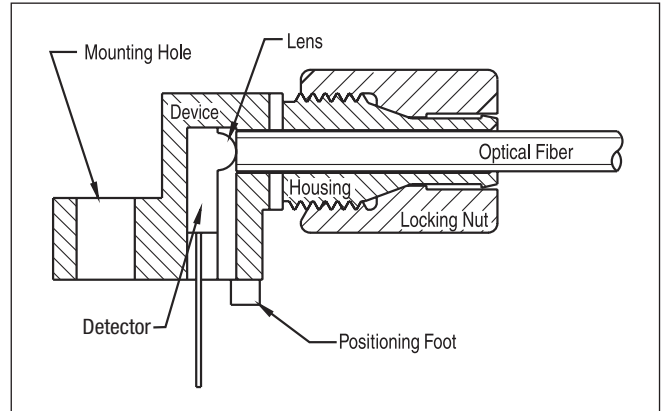

FIGURE 3. Cross-section of fiber optic device.

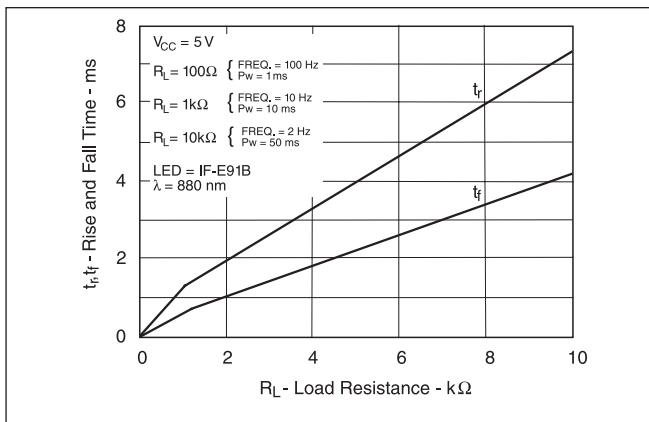

FIGURE 2. Rise and fall times versus load resistance.

### FIBER TERMINATION INSTRUCTIONS

1. Cut off the ends of the optical fiber with a single-edge razor blade or sharp knife. Try to obtain a precise 90-degree angle (square).
2. Insert the fiber through the locking nut and into the connector until the core tip seats against the internal micro-lens.
3. Screw the connector locking nut down to a snug fit, locking the fiber in place.

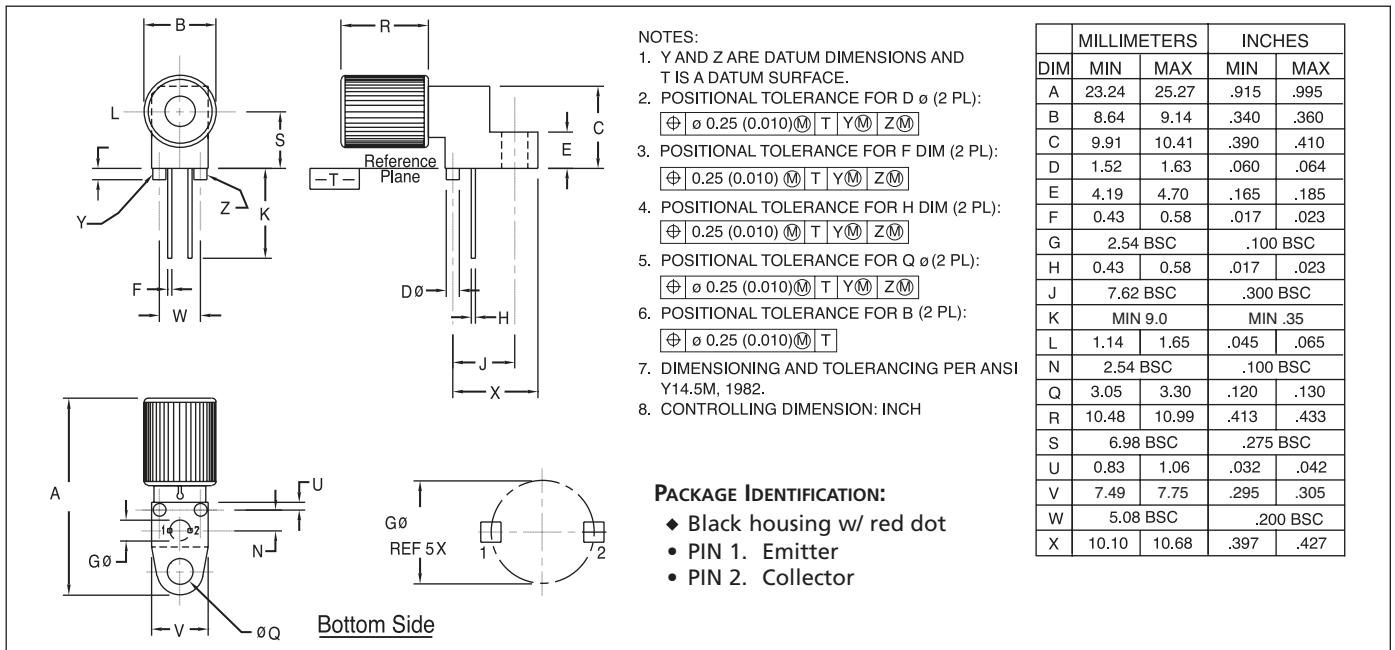

FIGURE 4. Case outline. Specifications are believed to be accurate but are subject to change. Industrial Fiber Optics assumes no responsibility for the consequences of using the information provided beyond replacement warranty for products not meeting stated specifications. Industrial Fiber Optics products are not authorized for use in life support applications without written approval from the President of Industrial Fiber Optics Corporation.

NOTE: • To avoid degraded device life due to package stress, do not bend or form leads outside the orientation shown on drawing.  
 • To avoid degrading the performance, it is recommended to not wave solder or wash the device.