

## DESCRIPTION

The IF-D92 is a high-sensitivity NPN phototransistor detector housed in a “connector-less” style plastic fiber optic package. Optical response of the IF-D92 extends from 400 to 1100 nm, making it compatible with a wide range of visible and near-infrared LEDs and laser diode sources. This includes 650 nm visible red LEDs used for optimum transmission in PMMA plastic optical fiber. The detector package features an internal micro-lens and a precision-molded PBT housing to ensure efficient optical coupling with standard 1000 μm core plastic fiber cable.

## APPLICATION HIGHLIGHTS

The IF-D92 is suitable for digital data links at rates up to 25 kbps. Analog bandwidths greater than 15 kHz are possible making the IF-D92 usable for high frequency audio transmission. Phototransistor operation provides high internal gain – reducing the amount of post-amplification required in many circuits. The integrated design of the IF-D92 makes it a simple, cost-effective solution in a variety of analog and digital applications.

## APPLICATIONS

- Low-Speed Digital Data Links
- Motor Controller Triggering
- Audio Links
- Medical Instruments
- Automotive Electronics
- Robotics Communications
- EMC/EMI Signal Isolation
- Electronic Games
- Process Control

## FEATURES

- ◆ High Optical Sensitivity
- ◆ Mates with Standard 1000 um Core Jacketed Plastic Fiber Optic Cable
- ◆ No Optical Design Required
- ◆ Inexpensive but Rugged Plastic Connector Housing
- ◆ Internal Micro-Lens for Efficient Optical Coupling
- ◆ Connector-Less Fiber Termination
- ◆ Light-Tight Housing provides Interference Free Transmission
- ◆ RoHS Compliant

## MAXIMUM RATINGS

( $T_A = 25^\circ\text{C}$ )

Operating and Storage Temperature Range  
( $T_{OP}, T_{STG}$ )..... $-40^\circ\text{ to }85^\circ\text{C}$

Junction Temperature ( $T_J$ )..... $85^\circ\text{C}$

Soldering Temperature  
(2mm from case bottom)  
( $T_S$ )  $t \leq 5$  s..... $240^\circ\text{C}$

Collector Emitter Voltage  
( $V_{CEO}$ ).....30 V

Emitter Collector Voltage  
( $V_{ECO}$ ) .....5 V

Collector Current ( $I_C$ ).....50 mA

Collector Peak Current  
( $I_{CM}$ )  $t = 1$  ms .....100 mA

Power Dissipation  
( $P_{TOT}$ )  $T_A = 25^\circ\text{C}$ .....100 mW

De-rate Above  $25^\circ\text{C}$ .....1.33 mW/ $^\circ\text{C}$

## CHARACTERISTICS ( $T_A = 25^\circ\text{C}$ )

Parameter	Symbol	Min.	Typ.	Max.	Unit
Wavelength for Maximum Photosensitivity	$\lambda_{PEAK}$	–	870	–	nm
Spectral Bandwidth (S=10% of SMAX)	$\Delta\lambda$	400	–	1100	nm
Switching Times (10% to 90% and 90% to 10%) ( $R_L=1$ k $\Omega$ , $I_C=1.0$ mA, $V_{CE}=5$ V, $\lambda=950$ nm))	$t_r, t_f$	-	20	-	$\mu\text{s}$
Responsivity min. @ 880 nm @ 632 nm	R	–	100 50	–	$\mu\text{A}/\mu\text{W}$ $\mu\text{A}/\mu\text{W}$
Collector Dark Current ( $V_{CE}=15$ volts)	$I_{CEO}$	–	-	100	nA
Breakdown Voltage ( $I_C=100\mu\text{A}$ )	$BV_{CEO}$	30	-	-	V
Breakdown Voltage ( $I_C= -100\mu\text{A}$ )	$BV_{ECO}$	5	-	-	V
Saturation Voltage ( $I_C=250\mu\text{A}$ , $H=100\mu\text{W}$ )	$V_{CE sat}$	-	0.15	-	V

**CAUTION:** The IF D92 is ESD sensitive. To minimize risk of damage observe appropriate precautions during handling and processing.

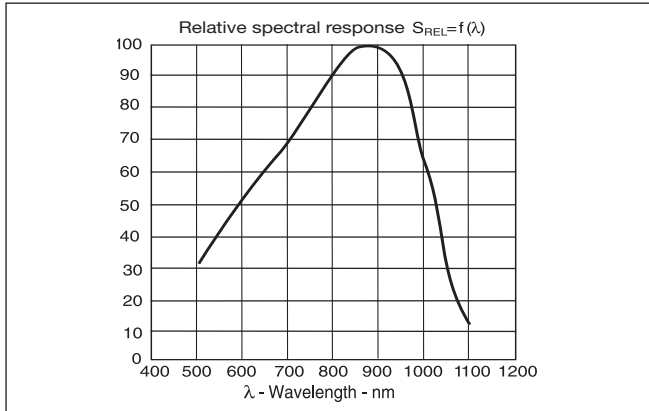

FIGURE 1. Typical detector response versus wavelength.

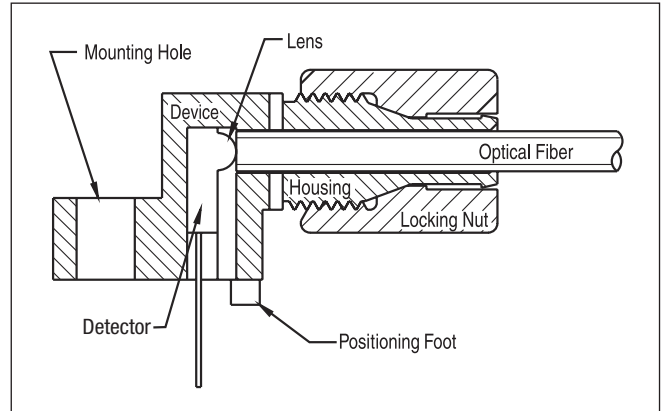

FIGURE 3. Cross-section of fiber optic device.

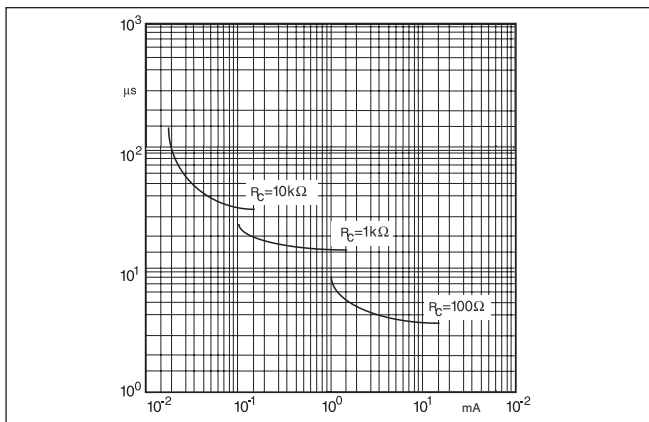

FIGURE 2. Rise and fall times of phototransistor.

### FIBER TERMINATION INSTRUCTIONS

1. Cut off the ends of the optical fiber with a single-edge razor blade or sharp knife. Try to obtain a precise 90-degree angle (square).
2. Insert the fiber through the locking nut and into the connector until the core tip seats against the internal micro-lens.
3. Screw the connector locking nut down to a snug fit, locking the fiber in place.

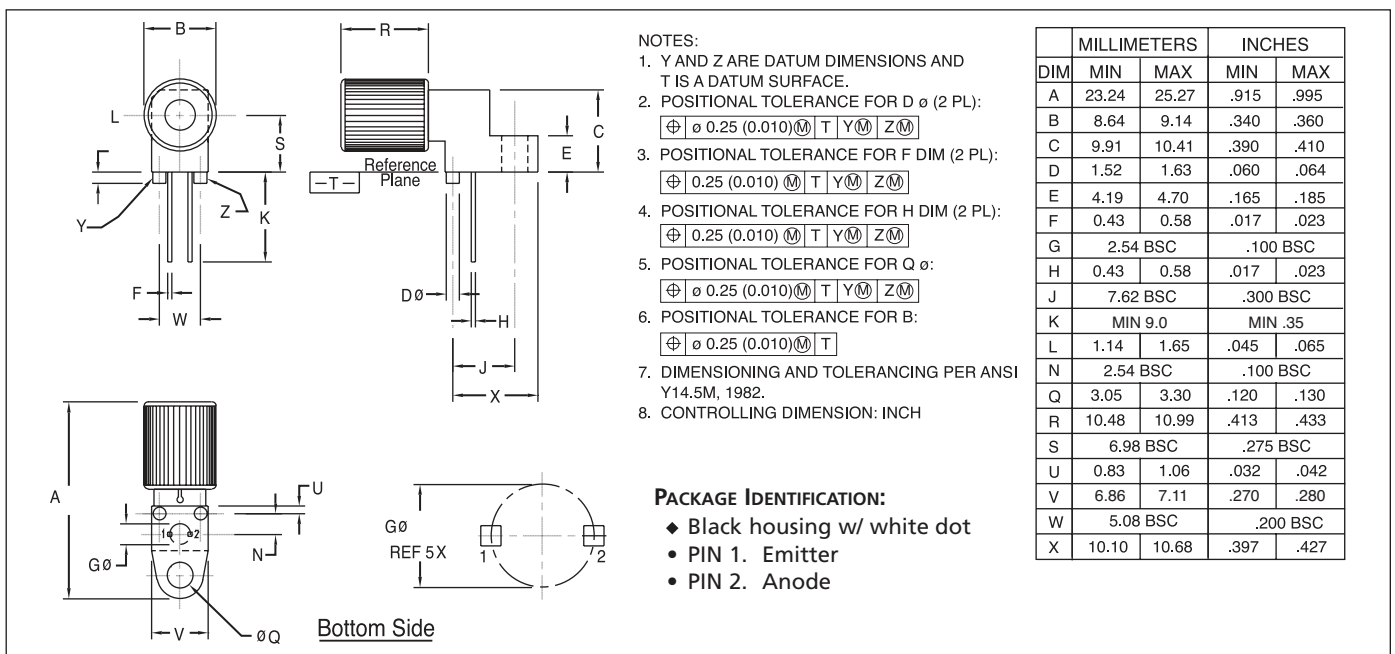

FIGURE 4. Case outline. Specifications are believed to be accurate but are subject to change. Industrial Fiber Optics assumes no responsibility for the consequences of using the information provided beyond replacement warranty for products not meeting stated specifications. Industrial Fiber Optics products are not authorized for use in life support applications without written approval from the President of Industrial Fiber Optics Corporation.

NOTE: • To avoid degraded device life due to package stress, do not bend or form leads outside the orientation shown on drawing.  
 • To avoid degrading the performance, it is recommended to not wave solder or wash the device.