

5

4

3

2

1

DRAWING NO.
CP8810-CUST

REVISIONS

01	OFFICIAL RELEASE			
	02-20-09	J W	B Y	T Thomas Chow



Description: Straight BNC Crimp Plug For RG59 Plenum Style Cable
 Part No: CP8810
 Application: For RG59 plenum, RG62 plenum Cable
 Crimp Tool: 24-9858P
 Impedance: 50 Ohms
 Frequency Range: 0-4 GHz
 Material: Body: Brass Nickel plated
 Contact: Brass Gold plated
 Insulator: Teflon
 Crimp Sleeve: Brass Nickel plated
 Coupling Nut: Zinc Nickel plated
 RoHS Compliance: Yes
 Technical Detail: Refer to Emerson Document P/N 27-0000

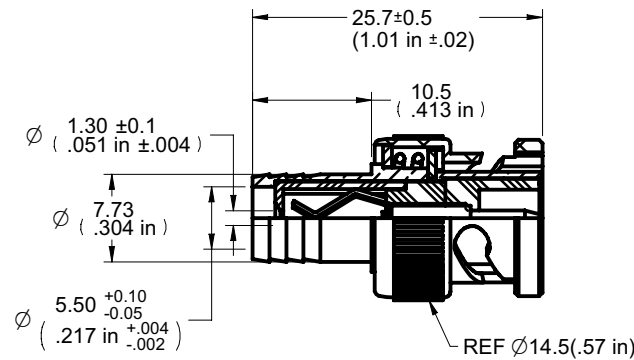
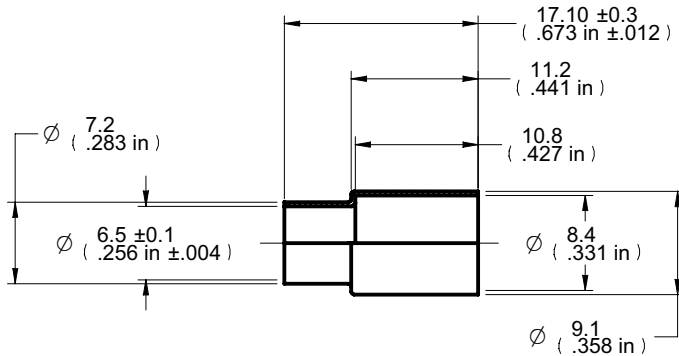

DIM OUTLINE

CUSTOMER COPY

受控 CONTROLLED DOCUMENT					
编号 P/N	CP8810-CUST	版本 Rev	01	日期 Rel'd Date	Apr29,09

TOLERANCE UNLESS OTHERWISE SPECIFIED		DRAWN BY IVON.W	DATE 02-20-09
DECIMALS	mm	CHECKED BY BETTY.YU	DATE 02-20-09
X	± 0.5	APPROVED BY THOMAS	DATE 02-20-09
X.X	± 0.3	U/M	mm
X.XX	± 0.1		
ANGLES	± 0.5°		

		Connectivity Solutions
TITLE STRAIGHT BNC CRIMP PLUG FOR RG59 PLENUM STYLE CABLE		
SHEET 1 OF 1	DRAWING NO. CP8810-CUST	SIZE A

THIS DRAWING WAS PRODUCED BY COMPUTER, DO NOT SCALE DRAWING OR UPDATE MANUALLY.

5

4

3

2

1