

World Modem™ FAX

Features

- ✂ Self-contained 14.4K – 33.6K baud modem family
- ✂ V.29, V.27ter, V.17, V.21 channel 2, V.34 half duplex, V.34 half duplex
- ✂ Compliant with global regulatory standards
- ✂ Distinctive ring detection
- ✂ Standard & Extended AT command set
- ✂ Serial host interface
- ✂ UART or parallel interface
- ✂ Automatic rate negotiation
- ✂ Type I and II caller ID decode
- ✂ Data/Fax discriminator
- ✂ Compatible with all Copeland Communications 2400, 14.4K, 33K and 56K high speed socket modems
- ✂ Socket Modem™ compatible
- ✂ Low power consumption
- ✂ Low Power Standby Mode
- ✂ Small footprint – 1.045” X 2.54”

Applications

- ✂ Global Embedded applications
- ✂ Point-of-sale terminals
- ✂ Set-top boxes
- ✂ Vending & gaming machines
- ✂ Security Systems
- ✂ Remote monitoring & control
- ✂ Remote telemetry and SCADA
- ✂ Fax Machines

Description

The CC-2435K2 and CC-2417K2 World modem™ FAX is a compact integrated 33Kbaud (14.4Kbaud for CC-2417K2) modem with Socket Modem™ compatibility. The modems feature a transformer-less DAA meeting global telephone system requirements, no electro-mechanical components and flexible DSP data pump. The modem is user-configurable to meet virtually all global telecom requirements. The modem supports serial host communications via flexible internal UART or a parallel interface. The modem conforms to the industry standard Socket Modem™ mechanical and interface specifications. Because of its built-in features and flexibility, many applications and OEM products can be created using the World Modem™ FAX. The World Modem™ FAX is an ideal modem for world-wide embedded applications due to its flexibility, global compliance, small size, low power consumption and upgradeability. Copeland Communications World Modem™ FAX are software and plug compatible and available in 14.4K and 33K baud versions.

Table of Contents

Features	1
Applications.....	1
Table of Contents.....	2
Block Diagram.....	3
User-Access Registers (U-Registers).....	35
FCC Compliance	58
CE DECLARATION OF CONFORMITY.....	60
Revision Information	61
Contact Information.....	62
Legal	62

Block Diagram

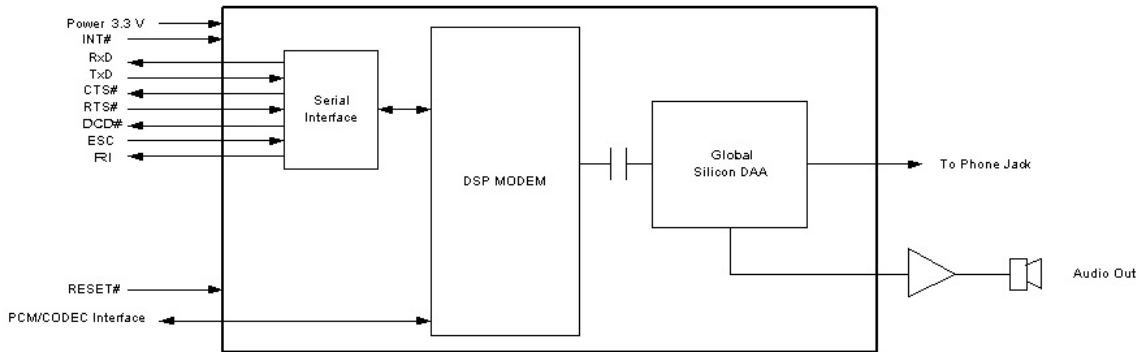

Host Interface

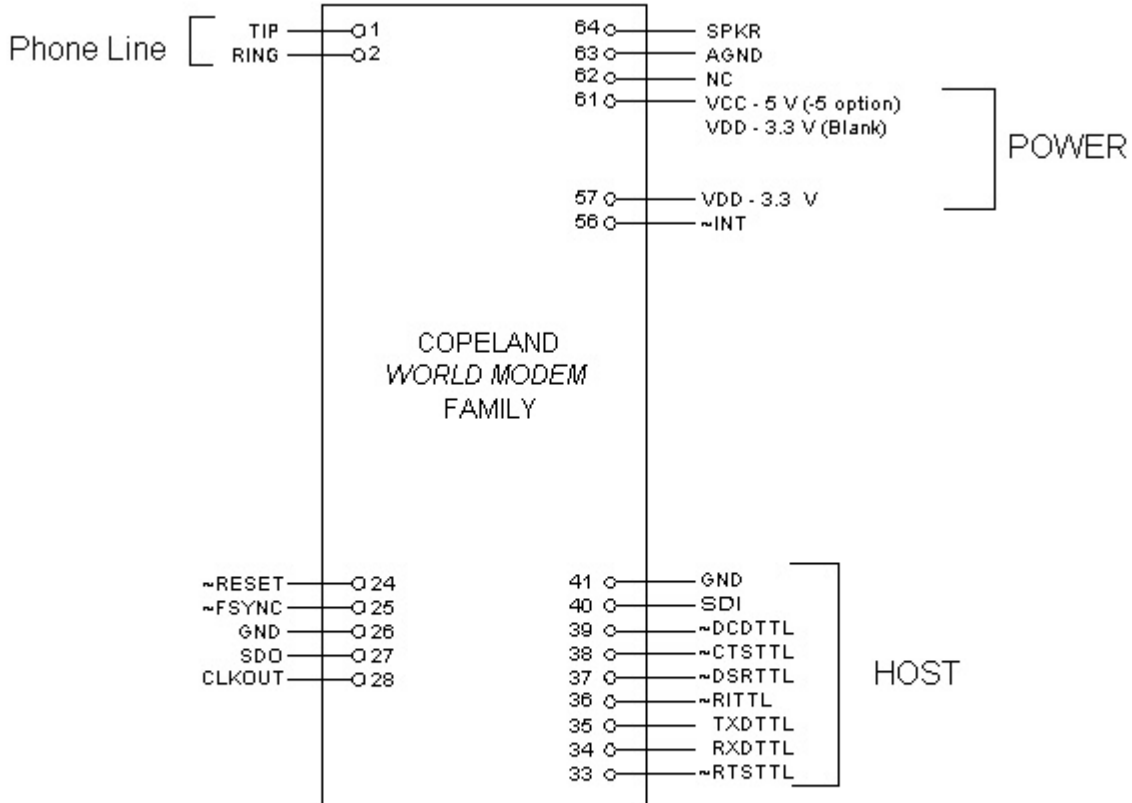

Note: Signals on pins 24,27,33-40 are TTL.

Serial Host Interface

The host interface control and data signals are 3.3volts and are 5 volt tolerant. The World modem II modems can be directly connected into 3.3 or 5 volt systems. Connect either pin 57 or pin 61 to 3.3V power supply.

Mechanical Outline

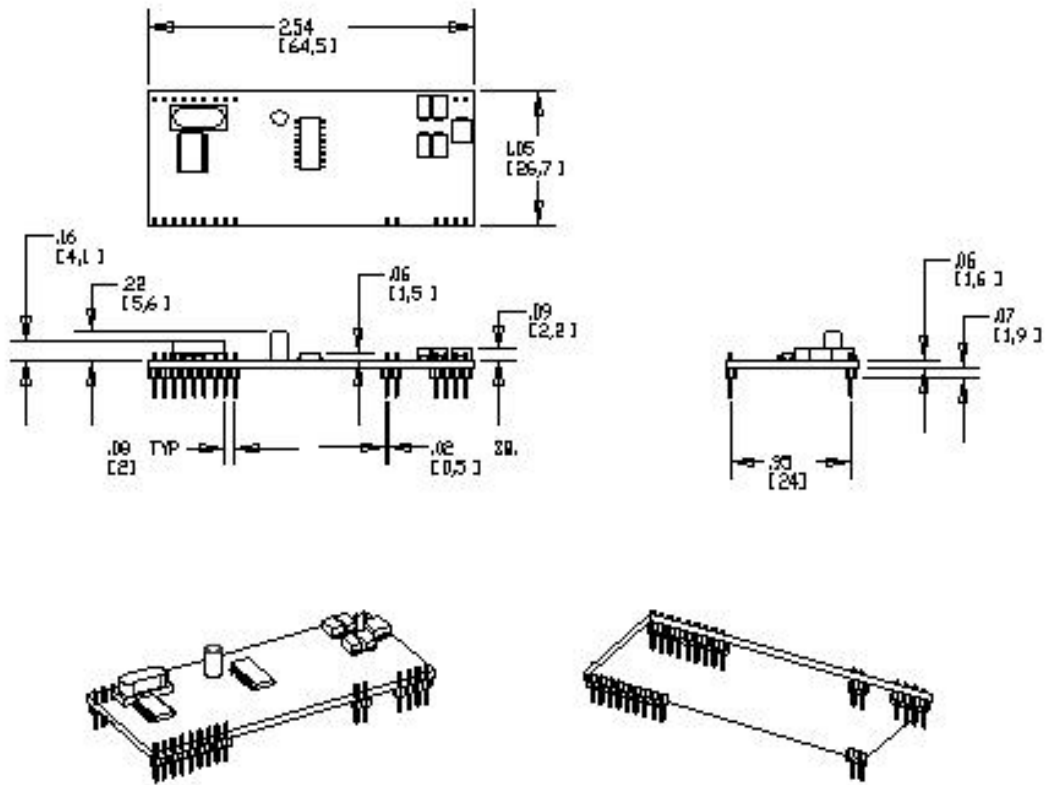

Mechanical

The modem module is on an 0.062 thick FR-4 PC board. The module has two rows of 2mm pins located 24mm on center. The module is designed to plug into 2 mm sockets with the same 24 mm spacing.

Due to the low mass of the board, no retention is required aside from the sockets. A large tie-wrap may be used to insure retention in high shock or vibration environments, if desired.

Specifications

Item	Specification
Fax Rate	
33.6 kbps*	ITU-T V.34
31.2 kbps*	ITU-T V.34
28.8 kbps*	ITU-T V.34
26.4 kbps*	ITU-T V.34
24.0 kbps*	ITU-T V.34
21.6 kbps*	ITU-T V.34
19.2 kbps*	ITU-T V.34
16.8 kbps*	ITU-T V.34
14.4 kbps	ITU-T V.34 or V.17
12.0 kbps	ITU-T V.34 or V.17
9600 bps	ITU-T V.34 , V.29 or V.17
7200 bps	ITU-T V.34 , V.29 or V.17
4800 bps	ITU-T V.34 or V.27ter
2400 bps	ITU-T V.34, V.22bis or V.27ter
1200 bps	ITU-T V.22bis
300 bps	ITU-T V.21 or V.21 channel 2
Data Format	
Bit format	Selectable 8,9,10 or 11 bits per character
Compatibility	ITU-T V.34*, V.29, V.27ter, V.22bis, V.22, V.21 and V.17
Control	AT command set
Fax Modulation	
2.4 to 33.6 kbps*	V.34 as specified by ITU-T
7.2 to 14.4 kbps	V.17 TCM as specified by ITU-T
7200 to 9600 bps	V.29 QAM as specified by ITU-T
2400 to 4800 bps	V.27ter DPSK as specified by ITU-T
300 bps	V.21 channel 2 FSK as specified by ITU-T
Transmit Carrier	
V.34*	As specified by ITU-T
ITU-T V.29	1700 Hz ± 1 Hz
ITU-T V.22, V.22bis	
Originate mode	1200 Hz ± 0.5 Hz
Answer mode	2400 Hz ± 1 Hz
ITU-T V.21	
Originate mode	Mark (980 Hz ± 12 Hz) Space (1180 Hz ± 12 Hz)
Answer mode	Mark (1640 Hz ± 12 Hz) Space (1850 Hz ± 12 Hz)
Receive Carrier	
ITU-T V.34*	As Specified by ITU-T
ITU-T V.29	1700 Hz ± 7 Hz
ITU-T V.22, V.22bis	
Originate Mode	2400 Hz ± 7 Hz
Answer Mode	1200 Hz ± 7 Hz
ITU-T V.21	
Originate Mode	Mark (980 Hz ± 12 Hz) Space (1180 Hz ± 12 Hz)
Answer Modem	Mark (1650 Hz ± 12 Hz) Space (1850 Hz ± 12 Hz)
Carrier Detect (level for ITU-T V.22bis, V.22, V.21) in Switched Network	Acquisition (-43 dBm) Release (-48 dBm)
Hysteresis	2 dBm minimum
DTE Interface	EIA/TIA-232-E (ITU-T V.24/V.28/ISO 2110)
Line Equalization	Automatic Adaptive

Specifications (Continued)

Item	Specification
Connection Options	Loss of Carrier in ITU-T V.22bis and lower
Dialing	Pulse and Tone
DTMF Output Level	Per Part 68
Pulse Dial Ratio	Make/Break 39/61%
Ring Cadence	On 2 seconds; Off 4 seconds
Call Progress Monitor	BUSY CONNECT (rate) NO ANSWER NO CARRIER NO DIALTONE OK RING RINGING
*NOTE: Supported on CC-2435 Only	

Asynchronous Serial Interface

The Asynchronous Serial Interface is a complete UART consisting of Receive and Transmit signals as well as RTS, CTS, DSR, DTR, DCD and RI control signals. RTS/CTS, DSR/DTR and XON/XOFF flow control are supported.

The UART is programmable to support a number of baud rates and data formats. Supported data rates and formats are:

Data Bits: 8

Stop Bits: 1

Baud Rates: 300, 600, 1200, 1800, 2400, 4800, 7200, 9600, 14.400, 19200, 28800, 38400, 56000, 57600, 115200, 128000, 230400, 460800, 921600

Functional Description

The World Modem™ FAX is a complete embedded fax modem with integrated direct access arrangement (DAA) that provides a programmable line interface to meet global telephone line requirements. This solution includes a DSP data pump, modem controller, on-chip RAM and ROM, codec, DAA and analog output. The World Modem™ FAX accepts standard modem AT commands and provides ITU-T T.31 compliant class one commands with fax connect rates up to 33.6/14.4 kbps over the Public Switched Telephone Network (PSTN). The World modem™ FAX features a complete set of modem protocols including all ITU-T standard formats up to 56 kbps. The World modem™ FAX provides numerous additional features for embedded modem applications. The modem includes full type I and type II caller ID detection and decoding for global standards. Call progress is supported through echoing result codes and is also programmable to meet global settings. Because the World modem™ FAX integrates the DAA, analog features, such as parallel phone detect, overcurrent detection, and global PTT compliance with a single design, are included. This device is ideal for embedded modem applications due to its small board space, low power consumption, and global compliance. The silicon DAA can be programmed to meet worldwide PTT specifications for ac termination, dc termination, ringer impedance, and ringer threshold. In addition, the World modem™ FAX has been designed to meet the most stringent worldwide requirements for out-of-band energy, billing-tone immunity, surge immunity, and safety requirements. The World modem™ FAX allows for rapid integration into existing modem applications by providing a serial interface that can directly communicate to either a microcontroller via a UART interface or a PC via an RS-232. This interface allows for PC evaluation of the modem immediately upon power-up via the AT commands using standard terminal software.

Host Interface

The host interface is available in serial or parallel TTL. By default, the host is configured for Autobaud recognition. The defaults can be changes after initialization by using standard AT commands. A true RS-232 interface is available on the World modem Evaluation Board.

Serial Interface

The pin out of the serial modem is shown in the figure below.

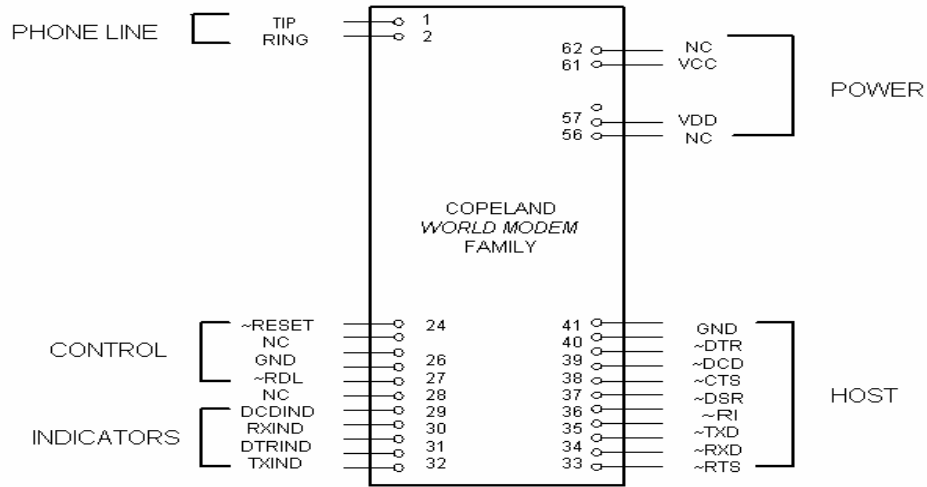

Note: Signals on pins 24,27,33-40 are TTL.

Serial Host Interface

Serial data

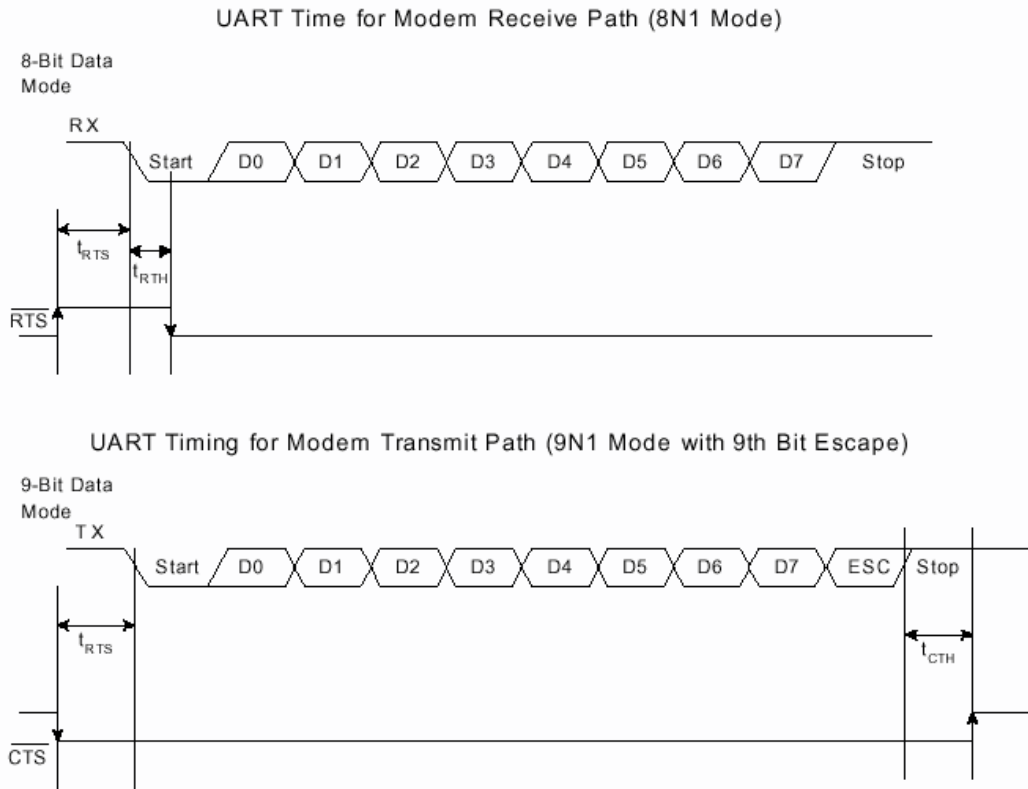

Figure 2. Asynchronous UART Serial Interface Timing Diagram

DTMF Detection / Generation

The World Modem™ FAX provides comprehensive DTMF tone generation by using the “ATDT” command. DTMF detection is only available in voice mode (FCLAS = 8). DTMF digits are reported from the modem to the host using <DLE> shielding

Voice Mode

The World Modem™ FAX supports voice mode. In voice mode the modem monitors the telephone line for several events such as DTMF detection, caller ID and ringing tone. Once these events are detected, the modem will send either a simple event code (a single character) or a complex even code (multiple charracters) preceded by a <DLE> character to the host. In voice mode the modem can also generate DTMF and signal tones using the +VTS command.

Voice mode is enabled by the AT command +FCLAS = 8. In voice mode the +VLS command is used to enable event reporting and tone generation and to control the on/off hook state.

Caller ID

The World Modem™ FAX supports full type I caller ID and type II caller ID in snoop mode. Caller ID is supported for the US Bellcore, European ETSI, UK and Japanese protocols and is enabled via the +VCID, +VCDT and +PCW commands.

Parallel Phone Detection

The World Modem™ FAX is able to detect when another telephone, modem or other device is using the telephone line. This allows the host to avoid interrupting another phone call when the phone line is already in use and to intelligently handle an interruption when the modem is using the phone line.

Event Description	Reporting	+VLS
Caller ID Report	Complex	0,4,20,21
Distinctive Ringing	Complex	0,4,20,21
RING	R	0,4,20,21
DTMF Received	1-9,A-D,*,#	1,5,20,21
Facsimile Calling (e.g. 1100 Hz)	c	1,5,20,21
Data Calling (e.g. 1300 Hz)	e	1,5,20,21
Presumed End of Message (QUIET) Time-out	q	1,5,20,21
Loop Current Interruption	l	1,5,20,21
Ringing Tone	r	1,5,20,21
BUSY	b	1,5,20,21
DIALTONE	d	1,5,20,21
Extension Phone On-hook	p	0,1,4,5,20,21
Extension Phone Off-hook	P	0,1,4,5,20,21
Facsimile or Data Answer (e.g. 2100 Hz)	a	1,5,20,21
Data Answer (e.g. 2225 Hz)	f	1,5,20,21

On-Hook Line-in-use Detection

When the modem is sharing the telephone line with other devices, it is important that it not interrupt a call in progress. To detect whether another device is using the shared telephone line, the host can use the modem to monitor the TIP-RING dc voltage with the line voltage sense (LVS) register (U6C, bits 15:8). The LVS bits have a resolution of 1 V per bit with an accuracy of approximately ±10%. Bits 0 through 6 of this 8-bit signed two's complement number indicate the value of the line voltage and the sign bit (7) indicates the polarity of TIP and RING.

Off-Hook Intrusion Detection

When the World Modem™ FAX is off-hook an algorithm is implemented in the modem to automatically monitor the TIP-RING loop current via the LCS register (U63, bits 7:0). Upon detecting an intrusion, the modem alerts the host of the condition via the INT pin. The LCS register has a resolution of 1.1 mA per bit and returns a zero value if less than the required loop current is present.

Overcurrent Detection

The World Modem™ FAX includes an overcurrent detection feature that measures the loop current at a programmable time after the modem goes off-hook. This allows the modem to detect if it is connected to an improper telephone line. The overcurrent detection feature may be enabled by setting the OCDM bit (U70, bit 11). OHT (U77, bits 8:0) sets the delay after off-hook until the loop current is measured.

Autobaud

The modem includes an automatic baud rate detection feature that allows the host to start transmitting data at any standard DTE rate from 300 bps to 307.2 kbps. This feature is enabled by default.

Flow Control

The modem provides both hardware and software flow control.

Hardware Flow Control

RTS
CTS
DSR
DTR

Status

In addition to flow control, the modem provides two hardware status signals

DCD
RI

Reset – A hardware reset is provided to reset the modem controller on power-up or to force the modem back to its default settings. This active low signal has an on-board pull up. Leave this pin unconnected if hardware reset is not needed.

Audio Output

The World Modem™ FAX modules support an analog (audio) output. This analog signal can be used for call progress monitoring.

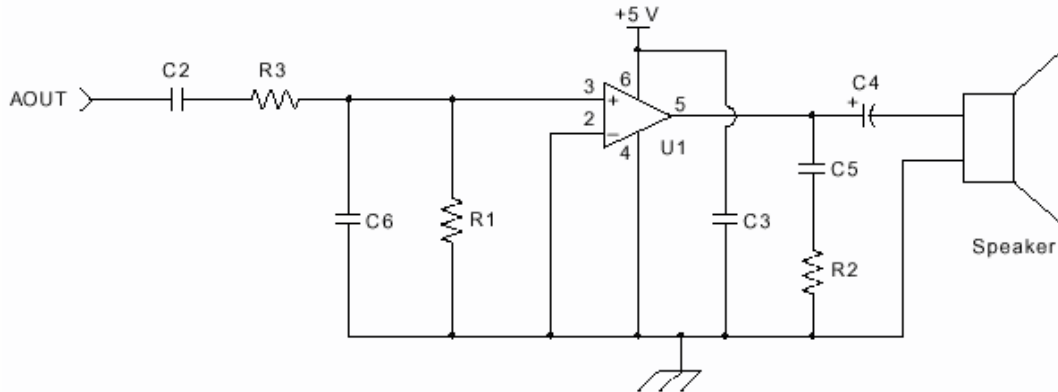

Optional Call Progress Monitor

Suggested Component Values

Symbol	Value
C2, C3, C5	0.1 μ F, 16 V, \pm 20%
C4	100 μ F, 16 V, Elec. \pm 20%
C6	820 pF, 16 V, \pm 20%
R1	10 k Ω , 1/10 W, \pm 5%
R2	10 Ω , 1/10 W, \pm 5%
R3	47 k Ω , 1/1 W, \pm 5%
U1	LM386

Power

The module is powered by an external 3.3 VDC source. Pins 57 and 61 are tied together internally on 3.3V models and either or both connected to an external 3.3V supply. On 5V models, Pin 61 ONLY can be connected to 5V. Pin 57 may still be used if a 3.3V power supply is required and 5V models are what is available. There is no on-board regulation of the power supply. The system needs to supply approximately 50 mA of current.

The power pin(s) should be decoupled with a good quality 0.01 μ F ceramic capacitor and a 1 μ F electrolytic or tantalum capacitor.

WARNING: ONLY connect one (1) of the power supply pins to either 3.3V or 5V on 5V models. Connecting both pins 57 and 61 to different power supplies WILL damage the modem and/or the system it is installed in.

See CCI Common Socket Interface Specification for more details.

Basic AT Command Set (Command Defaults in Bold)

Command	Action																				
\$	Display AT command mode settings																				
A	Answer incoming call																				
A/	Re-execute last command. This is the only command not preceded by "AT" or followed by a <CR>																				
Dn	Dial, followed by 1 or more dial command modifiers, manually dials a phone number																				
	<table border="1"> <thead> <tr> <th>Modifier</th> <th>Function</th> </tr> </thead> <tbody> <tr> <td>! or &</td> <td>Flash hook switch for FHT (U4F) ms (default: 500 ms)</td> </tr> <tr> <td>, or <</td> <td>Pause before continuing for S8 seconds (default: 2 seconds)</td> </tr> <tr> <td>;</td> <td>Return to AT command mode</td> </tr> <tr> <td>@</td> <td>Wait for silence.</td> </tr> <tr> <td>G</td> <td> <p>Polarity reversal detect. By placing the "G" character in the dial string (i.e. ATDTG1), the modem will monitor the telephone line for polarity reversals. If a busy tone is detected, the modem will report "POLARITY REVERSAL" if a polarity reversal was detected or "NO POLARITY REVERSAL" if a polarity reversal was not detected. In each case, the result code is followed by "OK". If the S7 timeout occurs before a busy tone is detected, the modem will report "NO CARRIER". Polarity reversal monitoring begins after the last digit is dialed and ends when the busy tone is detected or S7 timeout occurs.</p> </td> </tr> <tr> <td>L</td> <td>Redial last number.</td> </tr> <tr> <td>P</td> <td>Pulse (rotary) dialing</td> </tr> <tr> <td>T</td> <td>Tone (DTMF) dialing</td> </tr> <tr> <td>W</td> <td> <p>Wait for dial tone before continuing for S14 seconds (default: 12 seconds). Blind dialing modes X0, X1, and X3 do not affect the W command. If the DOP bit (U7A, bit 7) is set, the "ATDTW" command will cause the modem to pause dialing and either report an "OK" if a dial tone is detected or "NO DIALTONE" if a dial tone is not detected.</p> </td> </tr> </tbody> </table>	Modifier	Function	! or &	Flash hook switch for FHT (U4F) ms (default: 500 ms)	, or <	Pause before continuing for S8 seconds (default: 2 seconds)	;	Return to AT command mode	@	Wait for silence.	G	<p>Polarity reversal detect. By placing the "G" character in the dial string (i.e. ATDTG1), the modem will monitor the telephone line for polarity reversals. If a busy tone is detected, the modem will report "POLARITY REVERSAL" if a polarity reversal was detected or "NO POLARITY REVERSAL" if a polarity reversal was not detected. In each case, the result code is followed by "OK". If the S7 timeout occurs before a busy tone is detected, the modem will report "NO CARRIER". Polarity reversal monitoring begins after the last digit is dialed and ends when the busy tone is detected or S7 timeout occurs.</p>	L	Redial last number.	P	Pulse (rotary) dialing	T	Tone (DTMF) dialing	W	<p>Wait for dial tone before continuing for S14 seconds (default: 12 seconds). Blind dialing modes X0, X1, and X3 do not affect the W command. If the DOP bit (U7A, bit 7) is set, the "ATDTW" command will cause the modem to pause dialing and either report an "OK" if a dial tone is detected or "NO DIALTONE" if a dial tone is not detected.</p>
Modifier	Function																				
! or &	Flash hook switch for FHT (U4F) ms (default: 500 ms)																				
, or <	Pause before continuing for S8 seconds (default: 2 seconds)																				
;	Return to AT command mode																				
@	Wait for silence.																				
G	<p>Polarity reversal detect. By placing the "G" character in the dial string (i.e. ATDTG1), the modem will monitor the telephone line for polarity reversals. If a busy tone is detected, the modem will report "POLARITY REVERSAL" if a polarity reversal was detected or "NO POLARITY REVERSAL" if a polarity reversal was not detected. In each case, the result code is followed by "OK". If the S7 timeout occurs before a busy tone is detected, the modem will report "NO CARRIER". Polarity reversal monitoring begins after the last digit is dialed and ends when the busy tone is detected or S7 timeout occurs.</p>																				
L	Redial last number.																				
P	Pulse (rotary) dialing																				
T	Tone (DTMF) dialing																				
W	<p>Wait for dial tone before continuing for S14 seconds (default: 12 seconds). Blind dialing modes X0, X1, and X3 do not affect the W command. If the DOP bit (U7A, bit 7) is set, the "ATDTW" command will cause the modem to pause dialing and either report an "OK" if a dial tone is detected or "NO DIALTONE" if a dial tone is not detected.</p>																				
En	Local DTE echo																				
E0	Disable																				
E1	Enable																				
Hn	Hook switch																				
H0	Go on-hook (hang up modem).																				
H1	Go off-hook.																				

Basic AT Command Set (Command Defaults in Bold) (Continued)

Command	Action
In	Identification and checksum.
I0	Display World Modem™ chipset version. B, C, D, E, F, G, H....etc.
I1	Display World Modem™ firmware revision code (numeric).
I3	Display line-side revision code.
I6	Display chipset model number.
I7	Diagnostic result 1.
I8	Diagnostic result 2.
Mn	Speaker output (via AOUT pin 63)
M0	Speaker is always off.
M1	Speaker is on during dialing and handshaking. Off in data mode.
M2	Speaker is always on.
M3	Speaker is off while dialing. On during handshake and retraining.
On	Return to data mode from command mode operation.
O0	Return to data mode.
O1	Return to data mode and perform a full retrain (except for 300 bps).
O2	Return to data mode and perform rate renegotiation.
Qn	Response mode.
Q0	Enable result codes.
Q1	Disable result codes.
R	Initiate V.23 reversal.
Sn	S-register operation.
S\$	List contents of all S-registers.
Sn?	Displays contents of S-register n.
Sn=x	Set S-register n to value x. (x and n are decimal numbers).
Vn	Result code type.
V0	Numeric result codes.
V1	Verbal Result codes.
Xn	Call Progress Monitor (CPM). Controls which CPM signals are monitored and reported to the host from the modem.
X0	Basic results. Disable CPM, blind dial (doesn't wait for dial tone). CONNECT message does not include speed.
X1	Extended results. Disable CPM, blind dial. Connect message includes speed.
X2	Extended results and detect dial tone only.
X3	Extended results and detect busy only.
X4	Extended results and full CPM enabled. CONNECT message includes speed.
X5	Extended results. Full CPM and ringback detection enabled.

Basic AT Command Set (Command Defaults in Bold) (Continued)

Command	Action												
Yn	Long space disconnect. Modem hangs up after 1.5 seconds or more of continuous space while on-line.												
Y0	Disable.												
Y1	Enable.												
Z	Hard Reset - Resets the modem. (Same as asserting RESET# on pin 24).												
:E	Read from serial EEPROM.												
:I	Interrupt read. This command causes the modem to report the lower 8 bits of the interrupt register IO Control 0 (U70). The CID, OCD, PPD, and RI bits are also cleared.												
:M	Write to Serial EEPROM.												
:P	Program RAM write. This command is used to upload firmware supplied by CCI to the modem. Contact CCI for more information.												
:R	User-Access Register Read. This command allows the user to read from user-access registers. The format is "AT:Raa", where: aa = user-access address in hexadecimal. "AT:R" command causes all the U-registers to be displayed.												
:U	User-Access Register Write. Allows the user to write to the 16-bit user-access registers. The format is "AT:Uaa,xxx,yyy,zzzz" where aa = user-access address in hexadecimal. xxx = data in hexadecimal to be written to location aa. yyy = data in hexadecimal to be written to location (aa + 1). zzzz = data in hexadecimal to be written to location (aa + 2).												
+A8A : <value>	Answer Signal indication <table border="0"> <tr> <td><value></td> <td>Description</td> </tr> <tr> <td>0</td> <td>Indicates that the modem timed out waiting for an answering signal</td> </tr> <tr> <td>1</td> <td>Indicates V.8 ANSam signal (2100 Hz with amplitude modulation)</td> </tr> <tr> <td>2</td> <td>Indicates V.25 answer tone (2100 Hz)</td> </tr> <tr> <td>5</td> <td>Indicates sigA signal: V.22bis USB1 signal</td> </tr> <tr> <td>6</td> <td>Indicates sigA signal: V.32bis AC signal</td> </tr> </table>	<value>	Description	0	Indicates that the modem timed out waiting for an answering signal	1	Indicates V.8 ANSam signal (2100 Hz with amplitude modulation)	2	Indicates V.25 answer tone (2100 Hz)	5	Indicates sigA signal: V.22bis USB1 signal	6	Indicates sigA signal: V.32bis AC signal
<value>	Description												
0	Indicates that the modem timed out waiting for an answering signal												
1	Indicates V.8 ANSam signal (2100 Hz with amplitude modulation)												
2	Indicates V.25 answer tone (2100 Hz)												
5	Indicates sigA signal: V.22bis USB1 signal												
6	Indicates sigA signal: V.32bis AC signal												

Basic AT Command Set (Command Defaults in Bold) (Continued)

Command	Action
+A8C : <value>	Calling tone indication <value> Description 0 Indicates that the modem concluded answer tone transmission without reporting detection of any calling tone. 1 Indicates a CNG tone (1100 Hz) 2 Indicates 1300 Hz V.25 data modem calling tone
+A8E = <v8o>,<v8a>	V.8 and V.8bis operation control <v8o> Description 1 Enable modem controlled V.8 origination negotiation 6 Enable modem controlled V.8 origination negotiation, issue +A8x indications <v8a> Description 1 Enable modem controlled V.8 answer negotiation 5 Enable modem controlled V.8 answer negotiation, issue +A8x indications
+A8J: <value>	V.8 negotiation complete <value> Description 0 Indicates that the modem timed out waiting for a CJ signal 1 Indicates a CJ signal has been received by the remote modem
+A8M: <value>	V.8 menu report <value> Description 0 Indicates that the modem timed out waiting for a CM or JM signal <CM/JM hex string> This string is issued by either modem to indicate the contents of a valid received CM or JM signal.
+DR = n	Data compression reporting. N Mode 0 Disabled 1 Enabled If enabled, the intermediate result code is transmitted at the point after error control negotiation. The format of this result code is as follows: Result code Mode +DR:NONE Data compression is not in use +DR:V42B Rec. V.42bis is in use in both directions +DR:V42B RD Rec. V.42bis is in use in receive direction only +DR:V42B TD Rec. V.42bis is in use in transmit directions only

Basic AT Command Set (Command Defaults in Bold) (Continued)

Command	Action
+GCI = X	Country Settings - Automatically configure all registers for a particular country. X <u>Country</u> 0 Japan 9 Australia A Austria F Belgium 16 Brazil 1B Bulgaria 20 Canada 26 China 27 Columbia 2E Czech Republic 31 Denmark 35 Ecuador 3C Finland 3D France 42 Germany 46 Greece 50 Hong Kong 51 Hungary 53 India 57 Ireland 58 Israel 59 Italy 61 South Korea 69 Luxembourg 6C Malaysia 73 Mexico 7B Netherlands 7E New Zealand

Basic AT Command Set (Command Defaults in Bold) (Continued)

Command	Action
+GCI = X (cont)	82 Norway 87 Paraguay 89 Philippines 8A Poland 8B Portugal 9C Singapore 9F South Africa A0 Spain A5 Sweden A6 Switzerland B4 United Kingdom B5 United States B8 Russia FE Taiwan Note: U-Registers are configured to recommended values. The +GCI command resets the U- registers and the S6 and S7 S-registers to default values before setting country specific values. Changes may be made to individual registers after setting the AT+GCI command.
+GCI?	List current country code setting. (response: +GCI:<settings>).
+GCI = ?	Lists all possible country code settings.
+GMI	Report manufacturer ID
+GMM	Report chipset number: <system-side> / <line-side>
+GMR	Report chipset revision: <system-side rev> / <line-side rev>

Basic AT Command Set (Command Defaults in Bold) (Continued)

Command	Action
+IFC Options +IFC = A +IFC = A,B	Specifies the flow control to be implemented. A Specifies the flow control method used by the host to control data from the modem. 0 None 1 Local XON/OFF flow control. Does not pass XON/XOFF character to the remot modem. 2 Hardware flow control (RTS). B Specifies the flow control method used by the modem to control data from the host. 0 None 1 Local XON/OFF flow control. Does not pass XON/XOFF character to the remot modem. 2 Hardware flow control (CTS).
IPR = n	Select DTE rate N Description 0 Automatically detect baud rate 2400 DTE rate 2400 bits/s 9600 DTE rate 9600 bits/s 19200 DTE rate of 19.2 kbits/s 115200 DTE rate of 115.2 kbits/s Other DTE rates supported are: 300, 600, 1200, 4800, 7200, 12000, 14400, 38400, 57600, 230400, 245760, 307200
+ITF Options +ITF = A +ITF = A,B +ITF = A,B,C	Transmit flow control threshold. A Threshold above which the modem will generate a flow off signal. < 0 to 511> bytes B Threshold below which the modem will generate a flow on signal < 0 to 511> bytes C Polling interval for <BNUM> indicator 0 to 300 in 10 msec units.
+MR = X	Modulation reporting control. <u>X</u> Mode 0 Disabled 1 Enabled If enabled, the intermediate result code is transmitted at the point during connect negotiation. The format of this result code is asw follows: +MCR: <carrier> e.g. +MCR: V32B +MRR: <rate> e.g. +MRR: 14400

Basic AT Command Set (Command Defaults in Bold) (Continued)

Command	Action
+PCW = X	Controls the action to be taken upon detection of call waiting. <u>X</u> <u>Mode</u> 0 Toggle RI# and collect Type II Caller ID if enabled by +VCID. 1 Hang up. 2 Ignore Call Waiting.
+VCDT = X	Caller ID Type. <u>X</u> <u>Mode</u> 0 After ring only. 1 Always on. 2 UK 3 Japan
+VCID = X	Caller ID Enable. <u>X</u> <u>Mode</u> 0 Off 1 On - formatted 2 On - raw data format
+VDR = X	Distinctive Ring <u>X</u> <u>Mode</u> 0 Disable distinctive ring 1,0 Enable distinctive ring. The modem will report DRQF and DRON result codes only. DROF and DRON are reported in 100 ms units. 1,x Enable distinctive ring. The modem will report DROF and DRON result codes as well as RING result code x/10 seconds after the falling edge of a ring pulse. DROF and DRON are reported in 100 ms units.

Basic AT Command Set (Command Defaults in Bold) (Continued)

+VRN = n	<p>Ringing tone never appeared timer</p> <p>This command sets the amount of time in seconds the modem will wait looking for Ringing Tone. If the modem does not detect Ringing Tone in this time period, the modem will assume that the remote station has gone off-hook and return a OK result code. Default time is 0 seconds.</p>
+VSD = <sds>, <sdi>	<p>Silence detection</p> <p><sds> Noise level sensitivity</p> <p>127 Less aggressive (more sensitive, lower noise levels considered to be silence).</p> <p>128 Nominal level of sensitivity</p> <p>129 More aggressive (less sensitive, higher noise levels considered to be silence). <sdi> sets the length of the time interval in 0.1 second units, which must contain no or little activity, before the modem will report (QUIET) (<DLE><q>). Default is five seconds.</p>
+VTD = n	<p>DTMF / Tone duration timer</p> <p>This command sets the default DTMF / tone generation duration in 10 ms units for the +VTS command. Default time is one second (n = 100).</p>
+VTS = <string>	<p>DTMF and tone generation</p> <p>This command can be used to produce DTMF tones, single frequency tones and double frequency tones.</p>

Extended AT& Command Set (Command Defaults in Bold)

Command	Action
&\$	Display AT& current settings
&F	Restore factory default settings
&Pn	Japan pulse dialing
&P0	Configure the modem for 10 pulse-per-second pulse dialing
&P1	Configure the modem for 20 pulse-per-second pulse dialing
&Tn	Test mode
&T0	Cancel test mode (Escape to command mode to issue AT&T0). This command will also report the number of bit errors encountered on the previous &T4 or &T5 test.
&T2	Initiate ITU-T V.54 (ANALLOOP) test. Modulation set by &H AT command. Test loop is through the DSP (CC-14.4K2/CC-33K2/CC-56K2 only). The modem echoes data from TX pin back to RX pin.
&T3	Initiate ITU-T V.54 (ANALLOOP) test. Modulation set by &H AT command. Test loop is through the DSP, DAA interface section, DAA interface and analog hybrid circuit. The modem echoes data from TX pin back to RX pin.
&T4	Initiate transmit as originating modem with automatic data generation. Modulation, data rate and symbol rate are set by &H, &G and S41. Data pattern is set by the S40 register. Continues until the ATH command is sent after an escape into command mode.
&T5	Initiate transmit as answering modem with automatic data generation. Modulation, data rate, and symbol rate are set by &H, &G and S41. Data pattern is set by the S40 register. Continues until ATH command is sent after escape into command mode.
&T6	Compute checksum for firmware-upgradeable section of program memory. If no firmware upgrade is installed, &T6 returns 0x04474.
&Z	Enter low-power wake-on-ring mode.

Extended AT% Command Set (Command Defaults in Bold)

Command	Action								
%\$	Display AT% command settings.								
%On	Answer mode								
%O1	Modem will auto-answer a call in answer mode.								
%O2	Modem will auto-answer a call in originate mode.								
%Vn	Automatic Line Status Detection After the %V1 and %V2 commands are issued, the modem will automatically check the telephone connection for weather or not a line is present. If a line is present, the modem will automatically check if the line is already in use. Finally, the modem will check line status both before going off-hook and again before dialing. %V1 uses the fixed method, and %V2 uses the adaptive method. %V0 (default) disables this feature.								
%V0	Disable automatic line-in-use detection.								
&V1	Automatic Line Status Detection - Fixed Method. Description: Before going off-hook with the ATD, ATO or ATA commands the modem compares the line voltage via LVCS to registers NOLN (U83) and LIUS (U84): <table border="0"> <thead> <tr> <th><u>Loop Voltage</u></th> <th><u>Action</u></th> </tr> </thead> <tbody> <tr> <td>0 <= LVCS <= NOLN</td> <td>Report "NO LINE" and remain on-hook.</td> </tr> <tr> <td>NOLN <= LVCS <= LIUS</td> <td>Report "LINE IN USE" and remain on-hook.</td> </tr> <tr> <td>LIUS <= LCVS</td> <td>Go off-hook and establish a modem connection.</td> </tr> </tbody> </table> One the call has begun, the off-hook intrusion algorithm operates normally. In addition, the modem will report "NO LINE" if the telephone line is completely disconnected. If the HOI bit (U77, bit11) is set, "LINE IN USE" is reported upon intrusion.	<u>Loop Voltage</u>	<u>Action</u>	0 <= LVCS <= NOLN	Report "NO LINE" and remain on-hook.	NOLN <= LVCS <= LIUS	Report "LINE IN USE" and remain on-hook.	LIUS <= LCVS	Go off-hook and establish a modem connection.
<u>Loop Voltage</u>	<u>Action</u>								
0 <= LVCS <= NOLN	Report "NO LINE" and remain on-hook.								
NOLN <= LVCS <= LIUS	Report "LINE IN USE" and remain on-hook.								
LIUS <= LCVS	Go off-hook and establish a modem connection.								
&V2	Automatic Line Status Detection - Adaptive Method. Description: Before going off-hook with the ATD, ATO or ATA commands, the modem compares the line voltage (via LVCS to the NLIU (U85) register: <table border="0"> <thead> <tr> <th><u>Loop Voltage</u></th> <th><u>Action</u></th> </tr> </thead> <tbody> <tr> <td>0 <- LVCS <= (0.0625 x NLIU)</td> <td>Report "NO LINE" and remain on-hook.</td> </tr> <tr> <td>(0.0625 x NLIU) < LVCS <= (0.85 x NLIU)</td> <td>Report "LINE IN USE" and remain on-hook.</td> </tr> <tr> <td>(0.85 x NLIU) < LCVS</td> <td>Go off-hook and establish a moden connection.</td> </tr> </tbody> </table>	<u>Loop Voltage</u>	<u>Action</u>	0 <- LVCS <= (0.0625 x NLIU)	Report "NO LINE" and remain on-hook.	(0.0625 x NLIU) < LVCS <= (0.85 x NLIU)	Report "LINE IN USE" and remain on-hook.	(0.85 x NLIU) < LCVS	Go off-hook and establish a moden connection.
<u>Loop Voltage</u>	<u>Action</u>								
0 <- LVCS <= (0.0625 x NLIU)	Report "NO LINE" and remain on-hook.								
(0.0625 x NLIU) < LVCS <= (0.85 x NLIU)	Report "LINE IN USE" and remain on-hook.								
(0.85 x NLIU) < LCVS	Go off-hook and establish a moden connection.								

Extended AT\ Command Set (Command Defaults in Bold)

Command	Action
\\$	Display AT\ command settings.
\Bn	Character length will be automatically set in autobaud mode.
\B0	6N1 - six data bits, no parity, one stop bit, one start bit, eight bits total (N0 only) ¹
\B1	7N1 - seven data bits, no parity, one stop bit, one start bit, nine bits total (N0 only) ¹
\B2	7P1 - seven data bits, parity options by \P, one stop bit, one start bit, 10 bits total.
\B3	8N1 - eight data bits, no parity, one stop bit, one start bit, 10 bits total.
\B5	8P1 - eight data bits, parity optioned by \P, one stop bit, one start bit, 11 bits total (N0 only).
\B6	8X1 - eight data bits, one escape bit, one stop bit, one start bit, 11 bits total (enables ninth-bit escape mode).
\Pn	Parity type will be automatically set in autobaud mode.
\P0	Even
\P1	Space ¹
\P2	Odd
\P3	Mark ¹
\U	Serial mode – causes a low pulse (25 ms) on -RI and -DCD. –INT to be the inverse of ESC. – RTS to be inverse of –CTS Parallel mode – causes a low pulse (25 ms) on –INT. This command terminates with a –RESET
\Vn	Connect message type.
\V0	Report connect message and protocol message.
\V2	Report connect message only (exclude protocol message).
\V4	Report connect and protocol message with both upstream and downstream connect rates.
Notes:	
1. When in autobaud mode, \B0, \B1, and \P1 will not be detected automatically. The combination of \B2 and \P3 will be detected. This is compatible with 7N2. 7N1 may be forced by sending AT\T17\B1.	
2. The autobaud feature does not detect this rate.	
3. Default is \T16. \T9 may be defaulted as an order option. Contact the factory for details	

Fax AT Command Set (Command Defaults in Bold)

Command	Action
+FCLASS = N	Fax mode select n <u>Mode</u> 0 Data mode 1 Fax class 1 / 1.0 mode 8 Voice mode
+FAE = n	Data/Fax auto answer If enabled, the modem will automatically distinguish between a voice, data or fax call and issue either a DATA or FAX result code n <u>Mode</u> 0 Data / fax discriminator disabled 1 Data / fax discriminator enabled
+FTS = n	Stop transition and wait for n 10 ms intervals before responding with the OK result code
+FRS = n	Report back to the DTE with an OK result code after n 10 ms intervals of silence have been detected on the line.
+FTM = n	Transmit Data with carrier n.
+FRM = n	Receive Data with carrier n.
+FTH = n	Transmit Data with HDLC framing and carrier n. Only mandatory carrier, n = 3 supported.
+FRH = n	Receive Data with HDLC framing and carrier n. Only mandatory carrier, n = 3 supported.
+FAR = n	Adaptive reception control. If enabled, the modem will detect the selected carrier on V.21 control messages. If the expected carrier is detected, the modem will operate as specified in the respective +FRM = <mod> or +FRH = <mod> commands. If the V.21 flag preamble is detected instead, the modem will issue a +FRH:3 intermediate result code and then execute an implied +FRH = 3 command. n <u>Mode</u> 0 Adaptive reception disable 1 Adaptive reception enable
+FCL = <0-255>	Carrier loss timeout in 100 ms increments.
+FDD = n	Double escape character replacement. n <u>Decode of <DLE><DUB></u> <u>Encoding of <DLE><SUB></u> 0 <DLE><DLE> or discard <DLE><DLE><DLE><DLE> 1 <DLE><DLE> <DLE><SUB>
+FIT = A, B	DTE inactivity timeout A The inactivity timeout in seconds. Valid range from <0 – 255>. A zero disables the timeout. B Describes the action taken upon timeout. Valid range <0,1> 0 – Upon timeout, the modem will go on-hook then reset to +FCLASS = 0. 1 - Upon timeout, the modem will only go on-hook.
+FPR = n	DTE rate n <u>Mode</u> 0 Select automatic rate detection 1 Set DTE to 2400 bps 2 Set DTE to 4800 bps 3 Set DTE to 9600 bps 4 Set DTE to 19200 bps 8 Set DTE to 38400 bps 10 Set DTE rate to 38400 bps 18 Set DTE rate to 57600 bps
+FMI?	Report Manufacturer ID
+FMM?	Report modem chipset model
+FMR?	Report modem chipset revision

Fax AT Command Set (Command Defaults in Bold) (continued)

Command	Action
+FLO = n	Flow Control n Mode 0 No flow control 1 Software (XON/XOFF) flow control 2 Hardware (RTS/CTS) flow control
+F34 options +F34 = A +F34 = A,B +F34 = A,B,C +F34 = A,B,C,D +F34=A,B,C,D,E	Initial V.34 rate control A Max rate for the primary channel in half-duplex operation. Values range from 1 (2400 bps) to 14 (33.6 kbps) in 2400 bps increments. The default value 0 selects a max rate of 33.6 kbps. B Min rate for the primary channel in half-duplex operation. Values range from 1 (2400 bps) to 14 (33.6 kbps) in 2400 bps increments. The default value 0 selects a min rate of 2400 bps. C Control channel receive rate. Valid values are 0 (1200 bps), 1 (1200 bps), 2 (2400 bps). D Maxdata rate in full-duplex operation. Parameters are the same as "A" above E Min data rate in full-duplex operation. Parameters are the same as "B" above
+F34:	Initial V.34 rate indication.

Table 1. Carrier n

N	Modulation	Train time	Rate (bps)
3	V.21 ch 2	--	300
24	V.27 ter	--	2400
48	V.27 ter	--	4800
72	V.29	--	7200
73	V.17	Long	7200
74	V.17	Short	7200
96	V.29	--	9600
97	V.17	Long	9600
98	V.17	Short	9600
121	V.17	Long	12000
122	V.17	Short	12000
145	V.17	Long	14400
146	V.17	Short	14400

Result Codes¹

Numeric	Meaning	Verbal Response	X0	X1	X2	X3	X4	X5
0	Command was successful	OK	X	X	X	X	X	X
1	Link established at 300 bps or higher	CONNECT	X	X	X	X	X	X
2	Incoming ring detected	RING	X	X	X	X	X	X
3	Link dropped	NO CARRIER	X	X	X	X	X	X
4	Command failed	ERROR	X	X	X	X	X	X
5	Link established at 1200	CONNECT 1200		X	X	X	X	X
6	Dial tone not present	NO DIALTONE			X		X	X
7	Line busy	BUSY				X	X	X
8	Remote not answering	NO ANSWER	X	X	X	X	X	X
9	Ringback detected	RINGING						X
10	Link established at 2400	CONNECT 2400		X	X	X	X	X
11	Link established at 4800	CONNECT 4800		X	X	X	X	X
12	Link established at 9600	CONNECT 9600		X	X	X	X	X
14	Link established at 19200	CONNECT 19200 ²		X	X	X	X	X
15	Link established at 7200	CONNECT 7200		X	X	X	X	X
16	Link established at 12000	CONNECT 12000		X	X	X	X	X
17	Link established at 14400	CONNECT 14400		X	X	X	X	X
18	Link established at 16800	CONNECT 16800 ²		X	X	X	X	X
19	Link established at 21600	CONNECT 21600 ²		X	X	X	X	X
20	Link established at 24000	CONNECT 24000 ²		X	X	X	X	X
21	Link established at 26400	CONNECT 26400 ²		X	X	X	X	X
22	Link established at 28800	CONNECT 28800 ²		X	X	X	X	X
23	Link established at 31200	CONNECT 31200 ²		X	X	X	X	X
24	Link established at 33600	CONNECT 33600 ²		X	X	X	X	X
30	Caller ID mark detected	CIDM	X	X	X	X	X	X
31	Hookswitch flash detected	FLASH	X	X	X	X	X	X
32	UK CID State Tone Alert Signal detected	STAS	X	X	X	X	X	X
33	Overcurrent condition	X ³	X	X	X	X	X	X
40	Blacklist is full	BLACKLIST FULL (enabled via S42 register)	X	X	X	X	X	X
41	Attempted number is blacklisted	BLACKLISTED (enabled via S42 register)	X	X	X	X	X	X
42	No phone line present	NO LINE (enabled via %Vn commands)	X	X	X	X	X	X

Notes:

1. The connect messages shown in this table are sent when link negotiation is complete.
2. This message is only supported on the CC-2435K2
3. X is the only verbal response code that does not follow the <CR><LF> Result Code <CR><LF> standard. There is no leading <CR><LF>

Result Codes¹ (Continued)

Numeric	Meaning	Verbal Response	X0	X1	X2	X3	X4	X5
43	Telephone line is in use	LINE IN USE	X	X	X	X	X	X
44	A polarity reversal detected	POLARITY REVERSAL	X	X	X	X	X	X
45	A reversal NOT detected	NO POLARITY REVERSAL	X	X	X	X	X	X
70	No protocol	PROTOCOL: NONE	Set with \V0 command					
75	Link established at 75	CONNECT 75		X	X	X	X	X
77	V.42 protocol	PROTOCOL: V42	Set with \V0 command					
79	V.42bis protocol	PROTOCOL: V42bis	Set with \V0 command					
102	DTMF dial attempt on pulse dial only line	UN-OBTAINABLE NUMBER	X	X	X	X	X	X

1. The connect messages shown in this table are sent when link negotiation is complete.
2. This message is only supported on the CC-2435K2
3. X is the only verbal response code that does not follow the <CR><LF> Result Code <CR><LF> standard. There is no leading <CR><LF>

S-Registers

The S command allows reading (Sn?) or writing (Sn = x) the S-registers. The S-registers store values for functions that typically are rarely changed, such as timers or counters, and the ASCII values of control characters such as carriage return. The following table summarizes the S-register set.

S Register Definition

S-Register (Decimal)	Function	Default (Decimal)	Range	Units
0	Automatic answer - Number of rings the modem must detect before answering a call. 0 disables auto answer.	0	0 - 255	Rings
1	Ring counter.	0	0 - 255	Rings
2	ESC code character.	43 (+)	0 - 255	ASCII
3	Carriage return character.	13 (CR)	0 - 255	ASCII
4	Linefeed character.	10 (LF)	0 - 255	ASCII
5	Backspace character.	08 (BS)	0 - 255	ASCII
6	Dial tone wait timer - Number of seconds the modem waits before blind dialing. Only applicable if blind dialing is enabled (X0, X1, X3).	02	0 - 255	seconds
7	Carrier wait timer - Number of seconds the modem waits for carrier before timing out. This register also sets the number of seconds the modem waits for ring-back when originating a call before hanging up. This register also sets the number of seconds the answer tone will continue while using the AT*Y2A command.	80	0 - 255	seconds
8	Dial pause timer for , and < dial command modifiers.	02	0 - 255	seconds
9	Carrier presence timer - Time after a loss of carrier that a carrier must be detected before reactivating DCD. S9 is referred to as "carrier loss debounce time".	06	1 - 255	0.1 second
10	Carrier loss timer - Time the carrier must be lost before the modem disconnects. Setting 255 disables disconnect entirely. If S10 is less than S9, even a momentary loss of carrier causes a disconnect.	14	1 - 255	0.1 second
12	Escape code guard timer - Minimum guard time required before and after "+++" for the modem to recognize a valid escape sequence.	50	1 - 255	0.02 second
14	Wait for dial tone delay value (in relation to the W dial modifier). Starts when "W" is executed in the dial string.	12	0 - 255	seconds

S-Register Description (Continued)

S-Register (Decimal)	Function	Default (Decimal)	Range	Units
24	Sleep Inactivity Time – Sets the time that the modem operates in normal power mode with no activity on the serial port, parallel port or telephone line before entering low-power mode. This feature is disabled if the timer is set to 0.	0	0 - 255	Seconds
30	Disconnect Activity Timer – Sets the length of time that the modem stays online before disconnecting with no activity on the serial port, parallel port or telephone line (Ring, hookswitch flash, or caller ID). This feature is disabled if set to 0.	0	0 - 255	Minutes
38	Hang Up Delay Time – Maximum delay between receipt of ATH0 command and hang up. If timeout occurs before all data can be sent, the NO CARRIER (3) result code is sent (operates in V.42 mode only). "OK" response is sent if all data is transmitted before timeout. S38 = 255 disables timeout and the modem disconnects only if data is successfully sent or carrier is lost.	20	0 - 255	Seconds
40	Data Pattern – Data pattern generated during &T4 and &T4 transmit tests. 0 = All spaces (0s) 1 = All marks (1s) 2 = Random data	0	0-2	
41	V.34 Symbol rate – Symbol rate for V.34 when using the &T4 and &T5 commands. 0 = 2400 symbols/second 1 = 2743 symbols/second 2 = 2800 symbols/second 3 = 3000 symbols/second 4 = 3200 symbols/second 5 = 3429 symbols/second A valid combination of symbol rate (S41) and data rate (&G) must be selected. Symbol Rate Allowable Data Rates 2400 2400 – 26400 2743 4800 – 26400 2800 4800 – 26400 3000 4800 – 28800 3200 4800 – 31200 3429 4800 – 33600	0	0 – 5	

S-Register Description (Continued)

S-Register (Decimal)	Function	Default (Decimal)	Range	Units
42	Blacklisting - The modem will not dial the same number fore than two times in three minutes. An attempt to dial a 3rd time will result in a "BLACKLISTED" result code.	0 (disabled)	0-1	
	If the blacklist memory is full, any dial to a new number will result in a "BLACKLIST FULL" result code. Numbers are added to the blacklist only if the modem connection fails. The %B command will list the numbers on the blacklists			
	0 = disabled 1 = enabled			
43	Dial attempts to blacklist. When blacklisting is enabled with S42, this value controls the number of dial attempts that will result in a number being blacklisted.	4	0-4	-
44	Blacklist Timer. Period during which blacklisting is active	180	0-255	seconds
50	Minimum on-hook time - The modem will remain on-hook for S50 seconds. Any attempt to go off-hook will be delayed until this timer expires.	3	0 - 255	seconds
51	Number to start checking for an outside line on a PBX.	1	0 - 9	-

User-Access Registers (U-Registers)

The :U AT command is used to write these 16-bit U-Registers and the :R command is used to read them. U-registers are identified by a hexadecimal (hex) address.

Register	Name	Description	Default
U00	DT1A0	DT1 registers set the coefficients for stage 1 of the Dial Tone Detect filter. Default is for FCC countries.	0x0800
U01	DT1B1		0x0000
U02	DT1B2		0x0000
U03	DT1A2		0x0000
U04	DT1A1		0x0000
U05	DT2A0	Dial tone detect filters stage 2 biquad coefficients.	0x00A0
U06	DT2B1		0x6EF1
U07	DT2B2		0xC4F4
U08	DT2A2		0xC000
U09	DT2A1		0x0000
U0A	DT3A0	Dial tone detect filters stage 3 biquad coefficients.	0x00A0
U0B	DT3B1		0x78B0
U0C	DT3B2		0xC305
U0D	DT3A2		0x4000
U0E	DT3A1		0xB50A
U0F	DT4A0	Dial tone detect filters stage 4 biquad coefficients.	0x0400
U10	DT4B1		0x70D2
U11	DT4B2		0xC830
U12	DT4A2		0x4000
U13	DT4A1		0x80E2
U14	DTK	Dial tone detect filter output scalar.	0x0009
U15	DTON	Dial tone detect ON threshold.	0x00A0
U16	DTOF	Dial tone detect OFF threshold.	0x0070

User-Access Registers (continued)

Register	Name	Description	Default
U17	BT1A0	BT1 registers set the coefficients fo stage 1 of the Busy Tone Detect filter. Default is for FCC countries.	0x0800
U18	BT1B1		0x0000
U19	BT1B2		0x0000
U1A	BT1A2		0x0000
U1B	BT1A1		0x0000
U1C	BT2A0	Busy tone detect filter stage 2 biquad coefficients.	0x00A0
U1D	BT2B1		0x6EF1
U1E	BT2B2		0xC4F4
U1F	BT2A2		0xC000
U20	BT2A1		0x0000
U21	BT3A0	Busy tone detect filter stage 3 biquad coefficients.	0x00A0
U22	BT3B1		0x78B0
U23	BT3B2		0xC305
U24	BT3A2		0x4000
U25	BT3A1		0xB50A
U26	BT4A0	Busy tone detect filter stage 4 biquad coefficients.	0x0400
U27	BT4B1		0x70D2
U28	BT4B2		0xC830
U29	BT4A2		0x4000
U2A	BT4A1		0x80E2
U2B	BTK	Busy tone detect filter output scalar.	0x0009
U2C	BTON	Busy tone detect ON threshold.	0x00A0
U2D	BTOF	Busy tone detect OFF threshold.	0x0070
U2E	BMTT	Busy cadence minimum total time in seconds multiplied by 7200.	0x0870
U2F	BDLT	Busy cadence delta in seconds multiplied by 7200.	0x25F8
U30	BMOT	Busy cadence minimum on time in seconds multiplied by 7200.	0x0438
U31	RMTT	Ringback cadence minimum total time in seconds multiplied by 7200.	0x4650
U32	RDLT	Ringback cadence delta in seconds multiplied by 7200.	0xEF10

User-Access Registers (continued)

Register	Name	Description	Default
U33	RMOT	Ringback cadence minimum on time in seconds multiplied by 7200.	0x1200
U34	DTWD	Window to look for dialtone in seconds multiplied by 1000.	0x1B58
U35	DMOT	Minimum dialtone on time in seconds multiplied by 7200.	0x2D00
U37	PD0	Number of pulses to dial 0.	0x000A
U38	PD1	Number of pulses to dial 1.	0x0001
U39	PD2	Number of pulses to dial 2.	0x0002
U3A	PD3	Number of pulses to dial 3.	0x0003
U3B	PD4	Number of pulses to dial 4.	0x0004
U3C	PD5	Number of pulses to dial 5.	0x0005
U3D	PD6	Number of pulses to dial 6.	0x0006
U3E	PD7	Number of pulses to dial 7.	0x0007
U3F	PD8	Number of pulses to dial 8.	0x0008
U40	PD9	Number of pulses to dial 9.	0x0009
U42	PDBT	Pulse dial break time (ms units).	0x003D
U43	PDMT	Pulse dial make time (ms units).	0x0027
U45	PDIT	Pulse dial interdigit\ time (ms units).	0x0320
U46	DTPL	DTMF power level. 16-bit format is 0x0(H)(L)0 where H is the (-) dBm level of the high frequency DTMF tone and L is the (-) dBm level of the low-frequency DTMF tone. Note that twist may be specified here.	0x09B0
U47	DTNT	DTMF on time (ms units).	0x0064
U48	DTFT	DTMF off time (ms units).	0x0064
U49	RGFH	Ring frequency high - Maximum frequency ring to be considered a valid ring. RGFH = 2400/(maximum ring frequency).	0x0022
U4A	RGFD	Ring delta RGFD = 2400 Hz x (1/min ring freq (Hz)) - (1/max ring freq (Hz))	0x007A
U4B	RGMN	Ring cadence minimum ON time in seconds multiplied by 2400.	0x0258
U4C	RGNX	Ring cadence maximum total time in seconds multiplied by 2400.	0x007A
U4D	MOD1	bit-mapped register.	0x0000
U4E	PRDD	Pre-dial delay-time after ATD command that modem waits to dial (ms units). The modem stays on-hook during this time.	0x0000

User-Access Registers (continued)

Register	Name	Description	Default
U4F	FHT	Flash Hook Time. Time corresponding with "!" or "&" dial modifier that the modem goes on-hook during a flash hook (ms units).	0x01F4
U50	LCDN	Loop current debounce on time (ms units).	0x015E
U51	LCDF	Loop current debounce off time (ms units).	0x00C8
U52	XMTL	Transmit level (1 dB units) - Sets the modem data pump transmitter level. Default level of 0 corresponds to -9.86dBm. Transmit level = - (9.85 + XMTL dBm. Range = -9.85 to -48.	0x0000
U53	MOD2	This is a bit-mapped register.	0x0000
U62	DAAC1	This is a bit-mapped register.	0x0804
U63	DAAC3	This is a bit-mapped register.	
U65	DAAC4	This is a bit-mapped register.	0x00E0
U66	DAAC5	This is a bit-mapped register.	0x0040
U67	ITC1	This is a bit-mapped register.	0x0008
U68	ITC2	This is a bit-mapped register.	0x0000
U6A	ITC4	This is a bit-mapped register.	N/A
U6C	LVS	This is a bit-mapped register.	0x0000
U6E	CK1	This is a bit-mapped register.	0x1F20
U6F	PTMR	This is a bit-mapped register.	0x00FF
U70	IO0	This is a bit-mapped register.	0x2700
U71	IO1	This is a bit-mapped register.	0x0000
U76	GEN1	This is a bit-mapped register.	0x3240
U77	GEN2	This is a bit-mapped register.	0x401E
U78	GEN3	This is a bit-mapped register.	0x0000
U79	GEN4	This is a bit-mapped register.	0x0000
U7A	GENA	This is a bit-mapped register.	0x0000
U83	NOLN	No-Line threshold. If %V1 is set, NOLN sets the threshold for determination of line present vs. line not present.	0x0001
U84	LIUS	Line-in-use threshold. If %V1 is set, LIUS sets the threshold for determination of line in use vs. line not in use.	0x0007
U85	NLIU	Line-in-use/No line threshold. If %V2 is set, NLIU sets the threshold reference for the adaptive algorithm (see %V2).	0x0000
U86	V9AGG	V.90 rate adjustment for Japan (1333 BPS units).	0x0000

User-Access Registers (continued)

Register	Name	Description	Default
U87	SAM	This is a bit-mapped register.	0x0000
U9F	SASF	SAS frequency detection.	0x0000
UA0	SC0	SAS cadence 0. Sets the duration of the first SAS tone (ms).	0x01E0
UA1	SC1	SAS cadence 1. Sets the duration of the first SAS silence (ms).	0x0000
UA2	SC2	SAS cadence 2. Sets the duration of the second SAS tone (ms).	0x0000
UA3	SC3	SAS cadence 3. Sets the duration of the second SAS silence (ms).	0x0000
UA4	SC4	SAS cadence 4. Sets the duration of the third SAS tone (ms).	0x0000
UA5	SC5	SAS cadence 5. Sets the duration of the third SAS silence (ms).	0x0000
UA6	SC6	SAS cadence 6. Sets the duration of the forth SAS tone (ms).	0x0000
UA7	SC7	SAS cadence 7. Sets the duration of the forth SAS silence (ms).	0x0000
UA8	SC8	SAS cadence 8. Sets the duration of the fifth SAS tone (ms).	0x0000
UA9	SC9	SAS cadence 9. Sets the duration of the fifth SAS silence (ms).	0x0000

Bit Mapped U-Register Summary

Reg.	Name	Bit 15	Bit 14	Bit 13	Bit 12	Bit 11	Bit 10	Bit 9	Bit 8	Bit 7	Bit 6	Bit 5	Bit 4	Bit 3	Bit 2	Bit 1	Bit 0
U4D	MOD1		TOCT		NHFP	NHFD	CLPD		FTP	SPDM		GT18	GT55	CTE			
U53	MOD2	REV															
U62	DAAC1								OHS2						FOH	DL	
U63	DAAC3	LCS[:0]						ACT[3:0]									
U65	DAAC4		PWMG	PDN									PDL				
U66	DAAC5										FDT						
U67	ITC1			MIN[1:0]				ILIM		DCR	OHS			DCV[1:0]		RZ	RT
U68	ITC2														BTE	ROV	BTD
U6A	ITC4														OVL		
U6C	LVS	LVS[7:0]															
U6E	CK1				RJ[4:0]												
U70	IO0	HES		TES	CIDM	OCDM	PPDM	RIM	DCDM				CID	OCD	PPD	RI	DCD
U71	IO1												COMP				PRT
U76	GEN1	OHSR[7:0]						FACL	DCL[2:0]			ACL[4:0]					
U77	GEN2	IST[3:0]				HOI		AOC	OHT[8:0]								
U78	GEN3	IB[1:0]							IS[7:0]								
U79	GEN4											LVCS[4:0]					
U7A	GENA									DOP	ADD				V22HD	HDLC	FAST
U7C	GENC												RIGPO				RIG-POEN
U7D	GEND		NLM													ATZD	FDP
U87	SAM					MINT	SERM	FSMS	XMTT								
UAA	V29MODE														V29ENA		

Bit Mapped U-Register Detail (defaults in bold)

U4D MOD1

Bit	D15	D14	D13	D12	D11	D10	D9	D8	D7	D6	D5	D4	D3	D2	D1	D0
Name		TOCT		NHFP	NHFD	CLPD	CCAD	FTP	DSPDM		DGT18	GT55	CTE			
Type		R/W		R/W	R/W	R/W	R/W	R/W	R/W		R/W	R/W	R/W			

Reset Settings = 0x0000

Bit	Name	Function
15	Reserved	Read returns 0.
14	TOCT	Turn Off Calling Tone.
		0 = Disable.
		1 = Enable.
13	Reserved	Read returns 0.
12	NHFP	No Hook Flash Pulse.
		0 = Disable.
		1 = Enable.
11	NHFD	No Hook Flash Dial.
		0 = Disable.
		1 = Enable.
10	CLPD	Check Loop Current Before Dialing.
		0 = Ignore.
		1 = Check.
9	Reserved	Read returns 0.
8	FTP	Force Tone or Pulse.
		0 = Disable.
		1 = Enable.
7	SPDM	Skip Pulse Dial Modifier.
		0 = No.
		1 = Yes.
6	Reserved	Read returns 0.
5	GT18	1800 Hz Guard Tone Enable
		0 = Disable.
		1 = Enable.
4	GT55	550 Hz Guard Tone Enable.
		0 = Disable.
		1 = Enable.
3	CTE	Calling Tone Enable.
		0 = Disable.
		1 = Enable.
2:0	Reserved	Read returns 0.

U53 MOD2

Bit	D15	D14	D13	D12	D11	D10	D9	D8	D7	D6	D5	D4	D3	D2	D1	D0
Name	REV															
Type	R/W															

Reset settings = 0x0000

Bit	Name	Function
15	REV	V.23 Reversing 0 = Disable. 1 = Enable.
14:00	Reserved	Read returns 0.

U62 DAAC1

Bit	D15	D14	D13	D12	D11	D10	D9	D8	D7	D6	D5	D4	D3	D2	D1	D0
Name	0	0	0	0	1	0	0	OHS2	0	0	0	0	0	FOH	DL	0
Type	R/W													R/W	R/W	

Reset settings = 0x0804

Bit	Name	Function
15:12	Reserved	Must be set to 0.
11	Reserved	Must be set to 1.
10:9	Reserved	Must be set to 0.
8	OHS2	Oh-Hook Speed 2. This bit works in combination with the OHS bit (U67 bit 6) to set the on-hook speed. The on-hook speeds are measured from the time the OH bit is cleared until loop current equals zero. OHS OHS2 Mean On-Hook Speed 0 0 Less than 0.5ms 0 1 3 ms ± 10% (meets ETSI standard) 1 X 26 ms ± 10% (meets Australia spark quenching spec)
7:3	Reserved	Must be set to 0.
2	FOH	Fast Off-Hook. 0 = Automatic Calibration Time set to 426 ms. 1 = Automatic Calibration Time set to 106 ms.
1	DL	Isolation Digital Loopback (see the AT&T commands). 0 = Loopback occurs beyond the DAA interface, out to and including the analog hybrid circuit. 1 = Enables digital loopback mode across isolation barrier only.
0	Reserved	Must be set to 0.

U63 DAAC3

Bit	D15	D14	D13	D12	D11	D10	D9	D8	D7	D6	D5	D4	D3	D2	D1	D0
Name	LCS[7:0]							ACT[3:0]								
Type	R/W															

Rest settings = 0x0003

Bit	Name	Function
15:8	lcs[7:0]	Off-Hook Loop Current (1.1 mA/bit).
7:4	ACT[3:0]	AC Termination Select.
		ACT[3:0] AC Termination
		0000 Real 600 ?
		0011 220? + (820? 120nF) and 220? + (820? 115nF)
		0100 370? + (620? 310nF)
		1111 Global complex impedance
3:0	Reserved	Read returns 0x3.

U65 DAAC4

Bit	D15	D14	D13	D12	D11	D10	D9	D8	D7	D6	D5	D4	D3	D2	D1	D0
Name		PWMG	PDN									PDL				
Type		R/W	R/W									R/W				

Reset settings = 0x00E0

Bit	Name	Function
15	Reserved	Read returns 0.
14	TOCT	PWM Gain. 0 = No gain. 1 = 6 dB gain applied to AOUT.
13	PDN	Powerdown. Completely powerdown the modem chipset. Once set to 1, the modem must be reset to power on. 0 = Normal 1 = Powerdown.
12:8	Reserved	Read returns 0.
7:5	Reserved	Must not change in a read-modify-write.
4	PDL	Powerdown Line-Side Chip. (Typically used only for debug) 0 = Normal operation. 1 = Places Line side into powerdown mode.
3:0	Reserved	Must not change in read-modify-write.

U66 DAAC5

Bit	D15	D14	D13	D12	D11	D10	D9	D8	D7	D6	D5	D4	D3	D2	D1	D0
Name										FDT						
Type	R															

Reset settings = 0x0040

Bit	Name	Function
15:7	Reserved	Read returns 0.
6	FDT	Frame Detect. (Typically used only for board-level debug) 0 = Indicates the modem has not established frame lock. 1 = Indicates modem frame lock has been established.
5:4	Reserved	Read returns 0.
3:0	Reserved	Do not modify.

U67 ITC1

Bit	D15	D14	D13	D12	D11	D10	D9	D8	D7	D6	D5	D4	D3	D2	D1	D0
Name			MINI[1:0]				ILIM		DCR	OHS			DCV[1:0]		RZ	RT
Type	R/W			R/W			R/W	R/W	R/W			R/W	R/W	R/W		

Reset settings = 0x0008

Bit	Name	Function												
15:14	Reserved	Read returns 0.												
13:12	MINI[1:0]	<p>Minimum Operational Loop Current. Adjusts the minimum loop current at which the DAA can operate. Increasing the minimum operational loop current can improve the signal headroom at a lower TIP/RING Voltage.</p> <table border="1"> <thead> <tr> <th>MINI[1:0]</th> <th>Min Loop Current</th> </tr> </thead> <tbody> <tr> <td>00</td> <td>10 mA</td> </tr> <tr> <td>01</td> <td>12 mA</td> </tr> <tr> <td>10</td> <td>14 mA</td> </tr> <tr> <td>11</td> <td>16 mA</td> </tr> </tbody> </table>	MINI[1:0]	Min Loop Current	00	10 mA	01	12 mA	10	14 mA	11	16 mA		
MINI[1:0]	Min Loop Current													
00	10 mA													
01	12 mA													
10	14 mA													
11	16 mA													
11:10	Reserved	Read returns 0.												
9	ILIM	<p>Current Limiting Enable. 0 = Current limiting mode disabled. 1 = Current limiting mode enabled. This mode limits loop current to a maximum of 60 mA per the TBR21 standard.</p>												
8	Reserved	Read returns 0.												
7	DCR	<p>DC Impedance Selection. 0 - Normal DC Impedance. This mode should be used for all standard applications. 1 = 800Ω DC termination.</p>												
6	OHS	<p>On-Hook Speed. This bit works in combination with the OHS2 bit (U62, bit 8) to set the on-hook speed. The on-hook speeds are measured from the time the OH bit is cleared until loop current equals zero.</p> <table border="1"> <thead> <tr> <th>OHS</th> <th>OHS2</th> <th>Mean On-Hook Speed</th> </tr> </thead> <tbody> <tr> <td>0</td> <td>0</td> <td>Less than 0.5 ms</td> </tr> <tr> <td>0</td> <td>1</td> <td>3ms \pm 10% (meets ETSI standard)</td> </tr> <tr> <td>1</td> <td>X</td> <td>26 ms \pm 10% (meets Australia spark quenching spec)</td> </tr> </tbody> </table>	OHS	OHS2	Mean On-Hook Speed	0	0	Less than 0.5 ms	0	1	3ms \pm 10% (meets ETSI standard)	1	X	26 ms \pm 10% (meets Australia spark quenching spec)
OHS	OHS2	Mean On-Hook Speed												
0	0	Less than 0.5 ms												
0	1	3ms \pm 10% (meets ETSI standard)												
1	X	26 ms \pm 10% (meets Australia spark quenching spec)												
5:4	Reserved	Read returns 0.												
3:2	DCV[1:0]	<p>TIP/RING Voltage Adjust. These bits affect the TIP/RING voltage on the line. Low voltage countries should use a lower TIP/RING voltage. Raising the TIP/RING voltage can improve signal headroom.</p> <table border="1"> <thead> <tr> <th>DCV[1:0]</th> <th>DCT Voltage</th> </tr> </thead> <tbody> <tr> <td>00</td> <td>3.1V</td> </tr> <tr> <td>01</td> <td>3.2V</td> </tr> <tr> <td>10</td> <td>3.35V</td> </tr> <tr> <td>11</td> <td>3.5V</td> </tr> </tbody> </table>	DCV[1:0]	DCT Voltage	00	3.1V	01	3.2V	10	3.35V	11	3.5V		
DCV[1:0]	DCT Voltage													
00	3.1V													
01	3.2V													
10	3.35V													
11	3.5V													

Bit	Name	Function
1	RZ	Set this bit to 0.
0	RT	<p>Ringer Threshold Select. Used to satisfy country requirements on ring detection. Signals below the lower level does not generate a ring detection; signals above the upper level are guaranteed to generate a ring detection.</p> <p>0 = 11 to 22 V_{rms} 1 = 17 to 33 V_{rms}</p>

U68 ITC2

Bit	D15	D14	D13	D12	D11	D10	D9	D8	D7	D6	D5	D4	D3	D2	D1	D0
Name														BTE	ROV	BTD
Type														R/W	R/W	R/W

Reset settings = 0x0000

Bit	Name	Function
15:3	Reserved	Do not modify.
2	BTE	<p>Billing Tone Protect Enable. 0 = Disabled. 1 = Enabled.</p> <p>When set, the DAA responds automatically to a collapse of the line-derived power supply during a billing tone event. When off-hook, if BTE = 1 and BTD goes high, the dc termination is released (800? presented to the line). If BTE and RIM (U70, bit 9) are set, an RI (U70, bit1) interrupt also occurs when BTD goes high.</p>
1	ROV	<p>Receive Overload. The bit is set when the receive input has an excessive input level. This bit is cleared by writing a 0 to this location. 0 = Normal receive input level. 1 = Excessive receive input level.</p>
0	BTD	<p>Billing Tone Detected. This bit is set if a billing tone is detected. This bit is cleared by writing a 0 to this location. 0 = No billing tone. 1 = Billing tone detected.</p>

U6A ITC4

Bit	D15	D14	D13	D12	D11	D10	D9	D8	D7	D6	D5	D4	D3	D2	D1	D0
Name														OVL		
Type														R		

Reset settings = N/A

Bit	Name	Function
15:3	Reserved	Do not modify.
2	OVL	Overload Detected. This bit has the same function as ROV, but clears itself after the overload has been removed. This bit is not affected by the BTE bit.
1:0	Reserved	Do not modify.

U6C LVS

Bit	D15	D14	D13	D12	D11	D10	D9	D8	D7	D6	D5	D4	D3	D2	D1	D0
Name	LVS[7:0]															
Type	R															

Reset settings = 0x0000

Bit	Name	Function
15:8	LVS[7:0]	Line Voltage Status. Eight bit signed, two's complement number representing the tip/ring voltage. Each bit represents 1V. Polarity of the voltage is represented by the MSB (sign bit). 0000_0000 = Measured voltage is < 3V.
7:0	Reserved	Read returns zero.

U6E CK1

Bit	D15	D14	D13	D12	D11	D10	D9	D8	D7	D6	D5	D4	D3	D2	D1	D0
Name				R1[4:0]												
Type	R/W															

Reset settings = 0x1F20

Bit	Name	Function
15:13	Reserved	Do not modify.
12:8	R1[4:0]	R1 CLKOUT Divider See "World Modem™ Programmer's Guide for details.
7:0	Reserved	Read returns 0.

U70 IO0

Bit	D15	D14	D13	D12	D11	D10	D9	D8	D7	D6	D5	D4	D3	D2	D1	D0
Name	HES		TES	CIDM	OCDM	PPDM	RIM	DCDM	0			CID	OCD	PPD	RI	DCD
Type	R/W		R/W	R/W	R/W	R/W	R/W	R/W				R/W	R/W	R/W	R/W	R/W

Reset settings = 0x2700

Bit	Name	Function
15	HES	Hardware Escape Pin.
		0 = Disable.
		1 = Enable.
14	Reserved	Read returns 0.
13	TES	Enable "+++" Escape.
		0 = Disable.
		1 = Enable.
12	CIDM	Caller ID Mask.
		0 = Change in CID will not affect INT.
		1 = A low to high transition in CID activates INT#.
11	OCDM	Overcurrent Detect Mask.
		0 = Change in OCD does not affect INT. ("X" result code is not generated in command mode.)
		1 = A low to high transition in OCD will activate INT. ("X" result code is generated in command mode.)
10	PPDM	Parallel Phone Detect Mask.
		0 = Change in RI does not affect INT#.
		1 = A low to high transition in will activate INT.
9	RIM	Ring Indicator.
		0 = Change in RI does not affect INT#.
		1 = A low to high transition in RI activates INT.
8	DCDM	Data Carrier Detect Mask
		0 = Change in DCD does not affect INT#.
		1 - A high to low transition in DCD (U70, but 0), which indicates loss of carrier, activates INT.
7	Reserved	Must be set to zero.
6:5	Reserved	Read returns 0.
4	CID	Caller ID (sticky).
		Caller ID Preamble has been detected; data will soon follow. Clears on :I read.
3	OCD	Overcurrent Detect (sticky).
		Overcurrent condition has occurred. Clears on :I read.
2	PPD	Parallel Phone Detect (sticky).
		Parallel phone detected since last off-hook event. Clears on :I read.
1	RI	Ring Indicator.
		Active high bit when the modem is on-hook, indicates ring event has occurred. Clears on :I read.
0	DCD	Data Carrier Detect (status).
		Active high bit indicates carrier detected (equivalent to inverse of DCD# pin).

U71 IO1

Bit	D15	D14	D13	D12	D11	D10	D9	D8	D7	D6	D5	D4	D3	D2	D1	D0
Name												COMP				PRT
Type												R/W				R/W

Reset settings = 0x0000

Bit	Name	Function
15:5	Reserved	Read returns zero.
4	COMP	0 = Disables compression (PCM mode). 1 = Enables linear compression.
3:1	Reserved	Read returns zero.
0	PRT	0 = Disables PCM mode. 1 = Enables PCM mode.

U76 GEN1

Bit	D15	D14	D13	D12	D11	D10	D9	D8	D7	D6	D5	D4	D3	D2	D1	D0
Name	OHSR[6:0]							FACL	DCL[2:0]			ACL[4:0]				
Type	R/W															

Reset settings = 0x0000

Bit	Name	Function
15:5	OHSR[6:0]	Off-Hook Sample Rate (40 ms units). Sets the sample rate for the off-hook intrusion algorithms (1 second default).
8	FACL	Force ACL. 0 = While off-hook, ACL is automatically updated with LVCS. 1 = While off-hook, ACL does not change from the value written to it while on-hook.
7:5	DCL[2:0]	Differential Current Level (3 mA units). Sets the differential level between ACL and LVCS that will trigger an off-hook PPD interrupt (default = 2).
4:0	ACL[4:0]	Absolute Current Level (3 mA units). ACL represents the value of LVCS current when the modem is off-hook and all parallel phone are on-hook. If ACL = 0, it is ignored by the off-hook intrusion algorithm. The modem will also write ACL with the contents of LVCS before and intrusion and before going on-hook (default = 0)

U77 GEN2

Bit	D15	D14	D13	D12	D11	D10	D9	D8	D7	D6	D5	D4	D3	D2	D1	D0
Name	IST[3:0]			HOI	AOC	OHT[8:0]										
Type	RW															

Reset settings = 0x401E

Bit	Name	Function
15:12	IST[3:0]	Intrusion Settling Time (250 ms units). Delay between when the modem goes off-hook and the off-hook intrusion algorithm begins. Default is 1 s.
11	HOI	Hang-Up On Intrusion. 0 = Modem will not automatically hang up when and off-hook PPD interrupt occurs. 1 = Modem automatically hangs up on a PPD interrupt. If %Vn command are set, HOI also causes the "LINE IN USE" result code upon PPD interrupt.
10	Reserved	Read returns zero.
9	AOC	Auto Overcurrent. 0 = Disable 1 = Enable Note: AOC may falsely detect an overcurrent condition in the presence of line reversals or other transients. Therefore, it should not be used where line reversals are common or may be expected.
8:0	OHT[8:0]	Off-Hook Time (1 ms units). Time before LVCS is checked for overcurrent condition after going off-hook (30 ms default).

U78 GEN3

Bit	D15	D14	D13	D12	D11	D10	D9	D8	D7	D6	D5	D4	D3	D2	D1	D0
Name	IB[1:0]											IS[8:0]				
Type	R/W															

Reset settings = 0x0000

Bit	Name	Function
15:14	IB[1:0]	<p>Intrusion Blocking. Defines the method used to block the off-hook intrusion algorithm from operation after dialing has begun.</p> <p>0 = No intrusion blocking. 1 = Intrusion disabled from start of dial to end of dial. 2 = Intrusion disabled from start of dial to IS register time-out. 3 = Intrusion disabled from start of dial to connect ("CONNECT XXX", "NO DIALTONE", or "NO CARRIER").</p>
13:8	Reserved	Read returns zero.
7:0	IS[8:0]	<p>Intrusion Suspend (500 ms units). When IB = 2, this register sets the length of time from when the dialing begins that the off-hook intrusion algorithm is blocked (suspended) (default = 00000000b).</p>

U79 GEN4

Bit	D15	D14	D13	D12	D11	D10	D9	D8	D7	D6	D5	D4	D3	D2	D1	D0
Name												LVCS[4:0]				
Type	R															

Reset settings = 0x0000

Bit	Name	Function
15:5	Reserved	Read returns 0.
4:0	LVCS[4:0]	<p>Line Voltage Current Sense. Represents either the line voltage, loop current, or on-hook line monitor.</p> <p>On-Hook Voltage Monitor (2.75 V/bit ±20%) 00000 = No line connected. 00001 = Minimum line voltage ($V_{min} = 3.0V \pm 0.5V$). 11111 = Maximum line voltage ($87V \pm 20%$)</p> <p>Off-Hook Loop Current Monitor (3 mA/bit). 00000 = No loop current. 00001 = Minimum loop current. 11110 = Maximum loop current. 11111 = Loop current is excessive (overload). Overload > 140 mA in all modes except TBR21 Overload > 54 mA in TBR21 mode</p>

U7A GENA

Bit	D15	D14	D13	D12	D11	D10	D9	D8	D7	D6	D5	D4	D3	D2	D1	D0
Name								DOP	ADD					V22HD	HDLC	FAST
Type	R/W															

Reset settings = 0x0000

Bit	Name	Function
15:8	Reserved	Read returns zero.
7	DOP	Dial or pulse 0 = Normal ATDTW operation 1 = Use ATDTW for Pulse/Tone Dial Detection (see also ATDW command)
6	ADD	Adaptive Dialing 0 = Disable. 1 = Enable. Attempt DTMF dial the fall back to pulse dial if unsuccessful. First digit is dialed as DTMF. If a dialtone is still present after two seconds, the modem will redial as pulse. If no dialtone detected after two seconds, the modem will continue to dial as DTMF.
5:3	Reserved	Read returns zero.
2	V22HD	V.22bis Synchronous Mode* 0 = Normal ATDTW operation 1 = Use ATDTW for Pulse/Tone Dial Detection (see also ATDW command)
1	HDLC	Synchronous Mode* 0 = Normal asynchronous mode. 1 = Transparent HDLC mode.
0	FAST	Fast Connect* 0 = Normal modem handshake timing per ITU/Bellcore standards. 1 = Fast connect modem handshake timing.
*Note: When V22HD, HDLC or FAST bits are set \N0 (wire mode) must be used.		

U7C GENC

Bit	D15	D14	D13	D12	D11	D10	D9	D8	D7	D6	D5	D4	D3	D2	D1	D0
Name												RIGPO				RIGPOEN
Type												R		R/W		

Reset settings = 0x0000

Bit	Name	Function
15:5	Reserved	Read returns zero.
4	RIGPO	RI# RI#, follows this bit when RIGPIOEN = 1b.
3:1	Reserved	Read returns zero.
0	RIGPOEN	0 = RI# indicates valid ring signal. (Normal ring-indicator mode) 1 = RI# can be used as general purpose output and follows U7C[4] (RIGPO).

U7D GEND

Bit	D15	D14	D13	D12	D11	D10	D9	D8	D7	D6	D5	D4	D3	D2	D1	D0
Name		NLM													ATZD	FDP
Type	R/W															

Reset settings = 0x0000

Bit	Name	Function
15	Reserved	Read returns zero.
14	NLM	0 = Enables "No Loop Current" detect. 1 = Disables "No Loop Current" detect.
13:2	Reserved	Read returns zero.
1	ATZD	ATZ Disable
		0 = ATZ functions normally. 1 = Disable ATZ command.
0	FDP	FSK Data Processing 0 = FSK data processing stops when carrier is lost. 1 = FSK data processing continued for 2 bytes after carrier is lost.

U87 SAM

Bit	D15	D14	D13	D12	D11	D10	D9	D8	D7	D6	D5	D4	D3	D2	D1	D0
Name						MINT	SERM	FSMS	XMITT							
Type	R/W															

Reset settings = 0x0000

Bit	Name	Function
15:11	Reserved	Read returns zero.
10	MINT	<p>Minimal Transparency</p> <p>0 = Generates two-byte transparency sequences. This option will use codes <T5> through <T20>, if possible, for received data conning two back-to-back bytes requiring transparency.</p> <p>1 = Generates one-byte transparency sequences. This option will only use codes <T1> through <T4> for received data.</p>
9	SERM	<p>Special Error Reporting Mode</p> <p>0 = Ignore unrecognized in-band commands.</p> <p>1 = Generate <0x45> ("E" for error) in response to any unrecognized in-band commands.</p>
8	FSMS	<p>Framed Sub-Mode Startup</p> <p>0 = Upon successful connection, enter Transport Sub-Mode. An <FLAG> is required to enter Framed Sub-Mode.</p> <p>1 = Upon successful connection, immediately enter Framed Sub-Mode. The first received <ERR> from a successful hunt is transformed into an <flag>.</p>
7:0	XMTT	<p>Transmitter Threshold</p> <p>This value represents the number of bytes before a transmission is started.</p> <p>The following values are special:</p> <p>0 The same as ten. Upon receipt of ten bytes, data is transferred. The DTE must supply a closing flag within the required time or an underrun will occur.</p> <p>255 The same as infinity, e.g. never start a packet until the closing flag is received.</p>

Parallel Interface Registers

Parallel Interface 0 (0x00)

Bit	D7	D6	D5	D4	D3	D2	D1	D0
Name	TX/RX[7:0]							
Type	R/W							

Reset settings = 0x0000

Bit	Name	Function
7:0	TX/RX[7:0]	Parallel Interface Transmit/Receive. This register functions similarly to the serial port TX pin on writes to the parallel port and similarly to the serial port RX pin on reads from the parallel port

Parallel Interface 1 (0x01)

Bit	D7	D6	D5	D4	D3	D2	D1	D0
Name	RXF	TXE	REM	INTM	INT	ESC	RTS	CTS
Type	R	R	R	R/W	R	R/W	R/W	R

Reset settings = 0x0000

Bit	Name	Function
Y	RXF	Receive FIFO Almost Full (status). 0 = Receive FIFO (12 deep) contains 3 or more empty locations (RXF = 9). The host can clear the RXF interrupt without emptying the RX FIFO by writing a 0 to the RXF bit. This will disable the RXF interrupt until the host has emptied the FIFO. 1 = Receive FIFO contains 2 or less empty locations (RXF = 10).
6	TXE	Transmit FIFO Almost Empty (status). 0 = Transmit FIFO (14 deep) contains 3 or more characters (TXF = 3). 1 = Transmit FIFO contains 2 or less characters (TXF = 2). Note: TXE interrupt will not trigger if the CTS bit is inactive. Therefore, the host does not need to poll CTS while waiting for transmit FIFO to empty. TXE can be cleared by writing it to 0.
5	REM	Receive FIFO Empty. 0 = Receive FIO has valid data. 1 = Receive FIFO empty. Note: If the interim timer (see PTMR – U6F, bits 7:0) set by PTMR expires, it will cause an interrupt. This interrupt will not set RXF, TXE or INT. The interrupt handler on the host should then verify that REM = 0 and begin to empty the receive FIFO (Parallel Interface 0 register) until REM = 1.
4	INTM	Interrupt Mask. 0 = In parallel mode, the –INT pin is triggered by a rising edge on RXF or TXE only (default). 1 = In parallel mode, the –INT pin is triggered by a rising edge on RXF, TXE or INT.
3	INT	Interrupt 0 = No interrupt has occurred. 1 = Indicates that an interrupt (CID, OCD, PPD, RI, or DCD from U70) has occurred. This bit is cleared via the AT:I command.
2	ESC	Escape. Operation of this bit in parallel mode is functionally equivalent to the ESC pin in serial mode.
1	RTS	Request-to-send Operation of this bit in parallel mode is functionally equivalent to the –RTS pin in serial mode. Use of the –CTS and –RTS bits (as opposed to the TXE and RXF bits) allows the flow control between the host and the modem to operate one byte at a time, rather than in blocks.
0	CTS	Clear-to-Send Operation of this bit in parallel mode is functionally equivalent to the –CTS pin in serial mode. Use of the –CTS and –RTS bits (as opposed to the TXE and RXF bits) allows the flow control between the host and the modem to operate one byte at a time, rather than in blocks.

Ordering Information

CC-xxxxK2-tsv

- xxxx** – Model number
 - 2417 – 14.4K baud with FAX
 - 2435 – 33K baud with FAX
- t** – Temperature
 - C – Commercial (0 to +70°C)
 - I – Industrial (-20 to +85°C)
- s** – Host Interface
 - P – Parallel
 - S – TTL UART
- v** – Voltage
 - 5 – 5V (all IO is 3.3V and is 5V tolerant)
 - Blank – 3.3V (5V tolerant IO)

FCC Compliance

Certification Number: US:COPMM00BCC-xxK2

AC-REN: 0.0B

DC-REN: NA

Connectors: RJ11C

Compliance: FCC Part 15 and Part 68

CE DECLARATION OF CONFORMITY

Application of Council Directive(s): 89/336/EEC with Amending Directives:
92/31/EEC, 93/68/EEC, 98/13/EEC

Standard(s) to which conformity is declared:

STANDARDS

EN61000-6-3: 2001
EN55024: 1998, Amendment A1: 2001
EN55024: 1998, Amendment A1: 2001
TBR 21: 1998

ENVIRONMENTAL PHENOMENA

Emissions (EN55022: 1998)
Electrostatic Discharge (EN61000-4-2: 1995, A1: 1998, A2: 2001)
Radiated Immunity (EN 61000-4-3: 2002, A1: 2002)
Telecommunication Performance (TBR 21: 1998)

Manufacturer's Name: Copeland Communications, Inc.

Manufacturer's Address:

440 Colony Place
Gahanna, OH, USA 43230

Type of Equipment: Information Technology Equipment

Model No.: CC-xxK2 World Modem II Family

Year of Manufacture: 2004

Revision Information

Revision 1.0 Initial release

Contact Information

Copeland Communications, Inc.

440 Colony Place
Gahanna, OH 43230
Tel: (614) 475-1690
Fax: (614) 882-6062

Email: info@copelandcommunications.com
Internet: www.copelandcommunications.com

Legal

Information contained in this publication regarding device applications and the like is intended through suggestion only and may be superseded by updates. It is your responsibility to ensure that your application meets with your specifications. No representation or warranty is given and no liability is assumed by Copeland Communications, Incorporated with respect to the accuracy or use of such information, or infringement of patents or other intellectual property rights arising from such use or otherwise. Use of Copeland Communication's products as critical components in life support systems is not authorized except with express written approval by Copeland Communications. No licenses are conveyed, implicitly or otherwise, under any intellectual property rights

Trademarks: Socket Modem™ is a trademark of Conexant systems. All other products or technologies are the trademarks or registered trademarks of their respective holders.