

DELKIN DEVICES®

SLC Industrial microSD Memory Card Engineering Specification

Document Number: L5ENG00392

Revision: A



No part of this document may be reproduced, copied, recorded, stored in a retrieval system, or transmitted in any form without the written permission of Delkin Devices. This document is for informational use only and is subject to change without prior notice. Delkin Devices assumes no responsibility for any errors that may appear in this document.

Table of Contents

1	Overview	4
1.1	Product Features.....	4
1.2	Suggested Applications.....	5
1.3	Specifications Summary.....	6
1.4	Part Numbers and Availability	7
1.5	microSD Memory Card Read/Write Speeds.....	8
2	Mechanical Specifications	9
2.1	External Signal Contacts (ESC)	9
2.2	Design and Format.....	9
2.3	Reliability and Durability.....	10
2.4	Electrical Static Discharge (ESD) requirements	10
2.4.1	Contact Pads Area	10
2.4.2	Non-contact Pads Area	10
2.5	Mechanical Form Factor	11
3	microSD Card System Concept.....	16
3.1	Rewritable or Read-only Memory Cards	16
3.2	Card Capacity	16
3.3	Speed Class.....	17
3.4	Command System.....	18
3.4.1	Send Interface Condition Command (CMD8)	18
3.4.2	Command Functional Difference in High Capacity microSDHC Memory Card.....	20
4	microSD Card Interface.....	21
4.1	Pin Assignments	21
4.2	Pin Functions	21
4.3	SD Bus Topology	22
4.3.1	microSD Bus Mode Protocol.....	22
4.3.2	SPI Bus Mode Protocol	23
5	Read and Write Operations.....	25
5.1	microSD Bus Protocol	25
5.1.1	Command	25
5.1.2	Response	25
5.1.3	Data.....	25
5.2	SPI Bus Protocol	28
5.2.1	Command	28
5.2.2	Response	28
5.2.3	Data Read	28
5.3	Card Registers	29
5.3.1	OCR Register	29
5.3.2	CID Register	32
5.3.3	CSD Register.....	33
5.3.4	CSD_STRUCTURE	33
5.3.5	CSD Register (CSD Version 2.0).....	33

List of Figures

Figure 1. microSD Mechanical Description: Top and Side Views	11
Figure 2. microSD Bottom View and Keep Out Area	12
Figure 3. microSD Adapter Top View.....	12
Figure 4. microSD Adapter Contacts	13
Figure 5. microSD Adapter Bottom and Side Views.....	13
Figure 6. Host/Card Usability	17
Figure 7. microSD Contacts	21
Figure 8. microSD Memory Card System Bus	22
Figure 9. microSD Memory Card SPI System Bus.....	24
Figure 10. “no response” and “no data” Operations	25
Figure 11. Multiple Block Read Operation	26
Figure 12. Multiple Block Write Operation.....	26
Figure 13. Command Token Format	26
Figure 14. Response Token Format	27
Figure 15. Data Packet Format.....	27
Figure 16. Read Operation	28
Figure 17. Read Operation – Data Error	29
Figure 18. Write Operation.....	29

List of Tables

Table 1. microSD Card Capacities and Part Numbers.....	7
Table 2. microSD Memory Card Read/Write Speeds.....	8
Table 3. microSD Memory Card Package – External Signal Contacts.....	9
Table 4. microSD Memory Card package – Dimensions	9
Table 5. Reliability and Durability.....	10
Table 6. microSD Memory Card Package - Dimensions.....	14
Table 7. CMD8 Format Description.....	18
Table 8. CMD8 Card Operation	19
Table 9. microSD Memory Card Pin Assignments	21
Table 10. OCR Register Definition.....	31
Table 11. CID Register Definition.....	32
Table 12. CSD Register Fields (Version 2.0)	33
Table 13. SCR Fields.....	37
Table 14. SCR Register Structure Versions.....	37
Table 15. Physical Layer Specification Version	37
Table 16. SD-supported Security Algorithm	38
Table 17. SD Memory Card Supported Bus Widths.....	38

1 Overview

Delkin microSD cards combine a small form factor with a rugged, reliable package that's manufactured specifically for industrial applications. Unlike ordinary Secure Digital cards, the Delkin microSD encapsulates all internal components to seal out dust, moisture, and electrostatic discharge and to enhance shock and vibration performance. Its industrial operating temperature range of -40° to 85°C handles the harshest environments. Combining data-precise Single Level Cell (SLC) components with Error Correction Code and wear leveling algorithms gives the cards an endurance rating of 2,000,000 write/erase cycles. These RoHS-compliant cards are also supported by Delkin's locked-down Bill of Materials that ensures consistent product performance and future compatibility. With outstanding read/write speeds, these cards are ideal for automotive, security, medical, military, aviation, navigation, or any severe-service application where dependability, durability, and data integrity are mission critical.

1.1 Product Features

* Versatility

- Targeted for portable and stationary applications
- Designed for read-only and read/write cards
- Card detection (Insertion/Removal)
- Switch function command supports High-Speed, eCommerce, and future functions
- Supports both SD and SPI modes

* Capacity

- Standard Capacity microSD Memory Card: Up to and including 2GB
- High Capacity microSDHC Memory Card: 4GB, 8GB & 16GB (This version of the specification limits capacity up to and including 32GB)

* Power

- Operating voltage range: 2.7-3.6V

* Current

Typical Power Required (Ta=25°@3V)

	Value	Notes
Stand-by	75uA	Max – capacities up to 1GB
	120uA	Max – capacities 2GB and up
Read	47mA	Max (varies by capacity)
Write	59mA	Max (varies by capacity)

* Durability

- Over 2,000,000 Write Cycles
- Global Wear Leveling
- Correction of memory field errors
- Card removal during read operation will never harm the content.

*** Speed**

- Default mode: Variable clock rate 0-25Mhz, up to 12.5MB/sec interface speed (using 4 parallel data lines)
- High-Speed mode: Variable clock rate 0-50 MHz, up to 25 MB/sec interface speed (using 4 parallel data lines)
- Data transfer rate up to 25 MB/sec data transfer rate (using 4 parallel data lines).
Maximum data rate with up to 10 cards

*** Security**

- Contact Protection Mechanism: Complies with highest security of SDMI standard
- Password Protection of cards
- Copyright protection mechanism—Complies with highest security of SDMI standard
Password Protection of cards (CMD42 -LOCK- UNLOCK)
- Write Protect feature using mechanical switch
- Built-in write protection features (permanent and temporary)

*** Ease of Use**

- Card Detection (Insert/Remove)
- Application specific commands
- Comfortable erase mechanism
- Standard Protocol—attributes of the communication channel:
 - SD Memory Card Communication Channel
 - Six-wire communication channel (clock, command, 4 data lines)
 - Error-protected data transfer
 - Single or multiple block-oriented data transfer
- Standard Size—microSD Memory Card form factor defined in this specification
- Standard size microSD Memory Card thickness is defined as 1.0mm nominal (+/- 0.1mm).

1.2 Suggested Applications

- * Industrial Computers
- * Embedded Systems
- * Data Acquisition
- * Agriculture
- * Gaming
- * Telecommunications
- * Hundreds of other industries looking for a more robust and rugged digital storage option

1.3 Specifications Summary

The following table provides a summary of the specifications critical to most engineering solutions. For more detailed specifications, refer to the appropriate engineering specification section.

Specification	microSD
Model number	See Table 1
Capacity	128MB – 16GB
Form factor	11mm x 15mm x 1mm
Interface	Dual protocol modes (SD and SPI)
Interface connector	8-pin @ 0-50MHz
Hot swappable	Yes
RoHS compliant	Yes
Performance	
Interface burst speed	25MB/s
Sustained read transfer rate	Up to 23.0 MB/s (varies by capacity)
Sustained write transfer rate	Up to 21.4 MB/s (varies by capacity)
Reliability/Data Integrity	
MTBF (power-on hours)	>2,000,000 hours
Endurance (write/erase cycles)	>2,000,000 cycles
Data Retention	>10 years
Power	
Supply voltage	2.7V -3.6V
Typical power required	Ta=25°@3V
Stand-by	Capacities <2GB: 75uA, ≥2GB: 120uA
Read	Capacities <2GB: 38mA, ≥2GB: 47mA
Write	Capacities <2GB: 47mA, ≥2GB: 59mA
Environmental	
Storage temperature (°C)	-40 ~ 85°C
Operating temperature (°C)	-40 ~ 85°C
Relative humidity (non-condensing)	5 - 95%
Operating shock	40Gs at 11ms
Vibration	15Hz – 2,000Hz
Altitude	80,000 ft.
Durability	10,000 mating cycles

Physical Dimensions	
Length	15.0mm \pm 0.1mm
Width	11.0mm \pm 0.1mm
Thickness	1.0mm nominal (+/- 0.1mm See Fig. 2 C1+C3.)
Weight	0.5g typical

1.4 Part Numbers and Availability

microSD Memory Cards and adapters are available from Delkin in the capacities shown in the table below.

Table 1. microSD Card Capacities and Part Numbers

Capacity*	Delkin Part Number	Description
128MB	S212SFQSR-C1000-B	microSD Card with SD Adapter
128MB	S212SFQSR-C1047-B	microSD Card without SD Adapter
256MB	S225SFRTZ-C1001-B	microSD Card with SD Adapter
256MB	S225SFRTZ-C1047-B	microSD Card without SD Adapter
512MB	S251SFRTZ-C1001-B	microSD Card with SD Adapter
512MB	S251SFRTZ-C1047-B	microSD Card without SD Adapter
1GB	S20GMFYTY-C1000-B	microSD Card with SD Adapter
1GB	S20GMFYTY-C1047-B	microSD Card without SD Adapter
2GB	S202MFBSS-C1000-B	microSD Card with SD Adapter
2GB	S202MFBSS-C1047-B	microSD Card without SD Adapter
4GB	S204MFBSS-CX000-B	microSD Card with SD Adapter
4GB	S204MFBSS-CX047-B	microSD Card without SD Adapter
8GB	S208MFBSS-CX000-B	microSD Card with SD Adapter
8GB	S208MFBSS-CX047-B	microSD Card without SD Adapter
16GB	S216MFBSS-CX001-B	microSD Card with SD Adapter
16GB	S216MFBSS-CX047-B	microSD Card without SD Adapter

*Note: Usable capacities are within 10% of the gross capacity figures shown above, which is typical with all NAND flash devices, as a small portion of the total is needed for controller firmware and spare block reserves.

1.5 microSD Memory Card Read/Write Speeds

Read and write speeds vary based on memory capacity and other factors such as the size of data blocks, benchmarking tool utilized, computer speed, etc.

Table 2. microSD Memory Card Read/Write Speeds*

Capacity	Read Speed (MB/s)	Write Speed (MB/s)
128MB	14.3	6.0
256MB	15.9	6.0
512MB	15.9	11.0
1GB	19.0	11.0
2GB	23.0	9.0
4GB	23.0	21.0
8GB	23.0	21.3
16GB	23.0	21.4

*Actual speeds are dependent on host environment, configuration, write size, etc. and may vary.

2 Mechanical Specifications

2.1 External Signal Contacts (ESC)

Table 3. microSD Memory Card Package – External Signal Contacts

Number of ESCs	8 minimum
Distance from front edge	1.1mm
ESC grid	1.1mm
Contact dimensions	0.8mm X 2.9mm
Electrical resistance	30m Ω (worst case : 100m Ω)
Plating	
Nickel Base	5um (196.8 microinches) minimum
Gold	0.8um (31.5 microinches) minimum

2.2 Design and Format

Table 4. microSD Memory Card package – Dimensions

Dimensions	11mm x 15mm (min. 10.9mm x 14.9mm, max.11.1mm x 15.1mm) Testing according to MIL STD 883, Method 2016
Thickness	Inter Connect Area: 0.7mm \pm 0.05mm (see Figure 1, C1) Card Thickness: 1.0mm nom. (+/- 0.1mm, see Figure 1, C1/C3) Pull Area: 1.0mm \pm 0.1mm (see Figure 1, C1)
Printable area	Suggested outside the “Keep Out Area” (see Figure 3)
Surface	Plain (except contacts area)
Edges	Smooth edges
Inverse Insertion	Protection on upper-right corner (top view)
Position of ESC contacts	Along middle of shorter edge

2.3 Reliability and Durability

Table 5. Reliability and Durability

Temperature	Operation: -40°C / 85 °C Storage: -40 °C (168h) / 85 °C (500h) Junction temperature: 95 °C max.
Moisture and Corrosion	Operation: -40°C / 95% relative humidity Storage: -40 °C / 93% relative humidity (500h) Salt water spray: 3% NaCl/35C;24h acc.MIL STD Method 1009
Reliability	2,000,000 write cycles
Durability	10,000 mating cycles
Bending1	10N
Torque1	0.10N*m ± 2.5 °C Max
Drop Test	1.5m free fall
UV light exposure	UV: 254nm, 15Ws/cm2 according to ISO 7816-1
Visual inspection shape and form1	No mold skin; complete form; no cavities Surface smoothness ≤0.1mm/cm2 within contour; no cracks, No pollution (fat, oil dust, etc.)

Note: SDA's recommended test methods for torque, bending and warpage are defined separately.

2.4 Electrical Static Discharge (ESD) requirements

ESD testing should be conducted according to IEC 61000-4-2. Required ESD parameters are:

- * **Human Body Model:** ±4 KV 100pF / 1.5KΩ
- * **Machine model:** ±0.25 KV 200pF / 0Ω

2.4.1 Contact Pads Area

- * **Human Body Model:** ±4KV, according to IEC 61000-4-2

2.4.2 Non-contact Pads Area

- * **Coupling Plane Discharge:** ±8KV
- * **Air Discharge:** ±15KV

2.5 Mechanical Form Factor

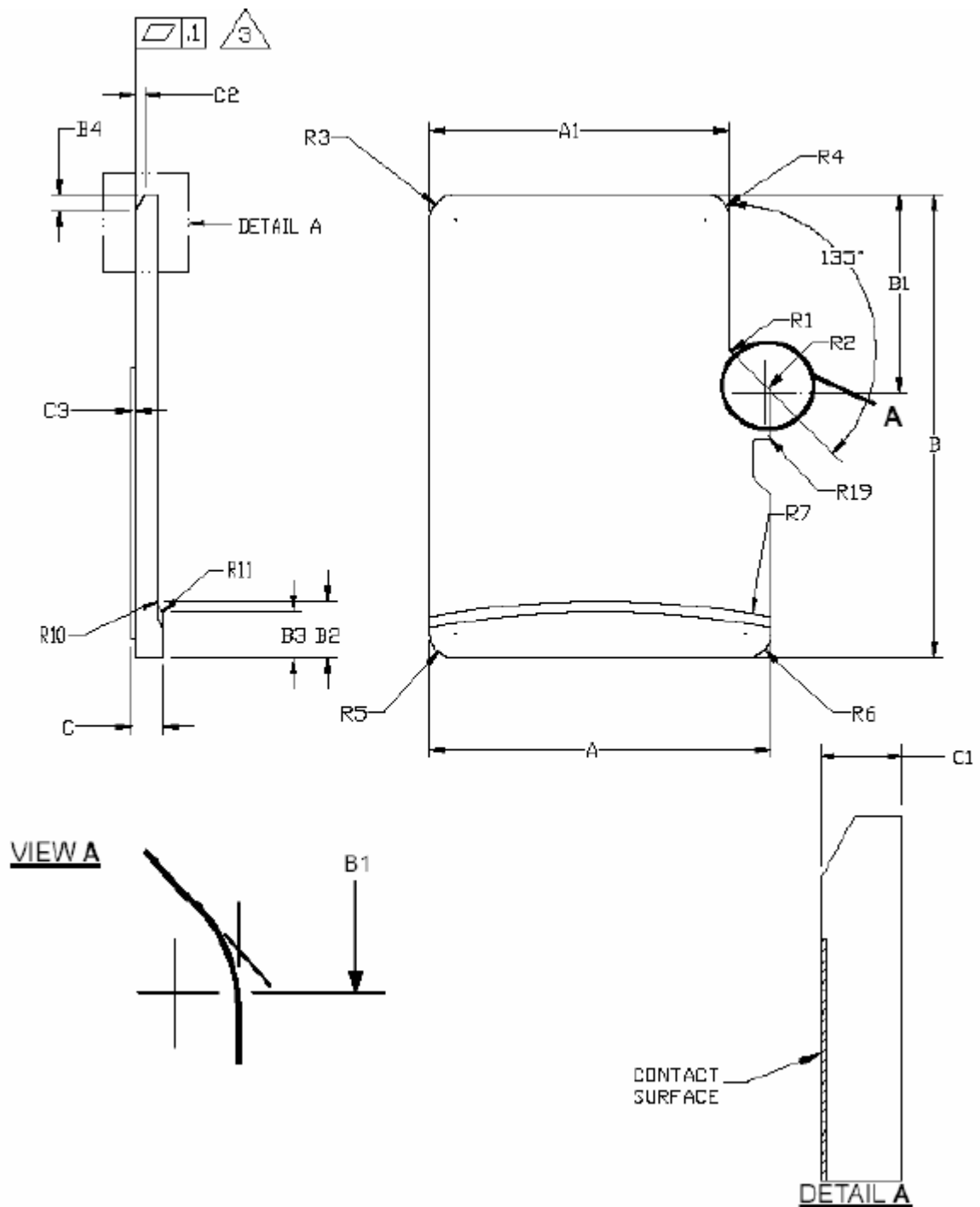

Figure 1. microSD Mechanical Description: Top and Side Views

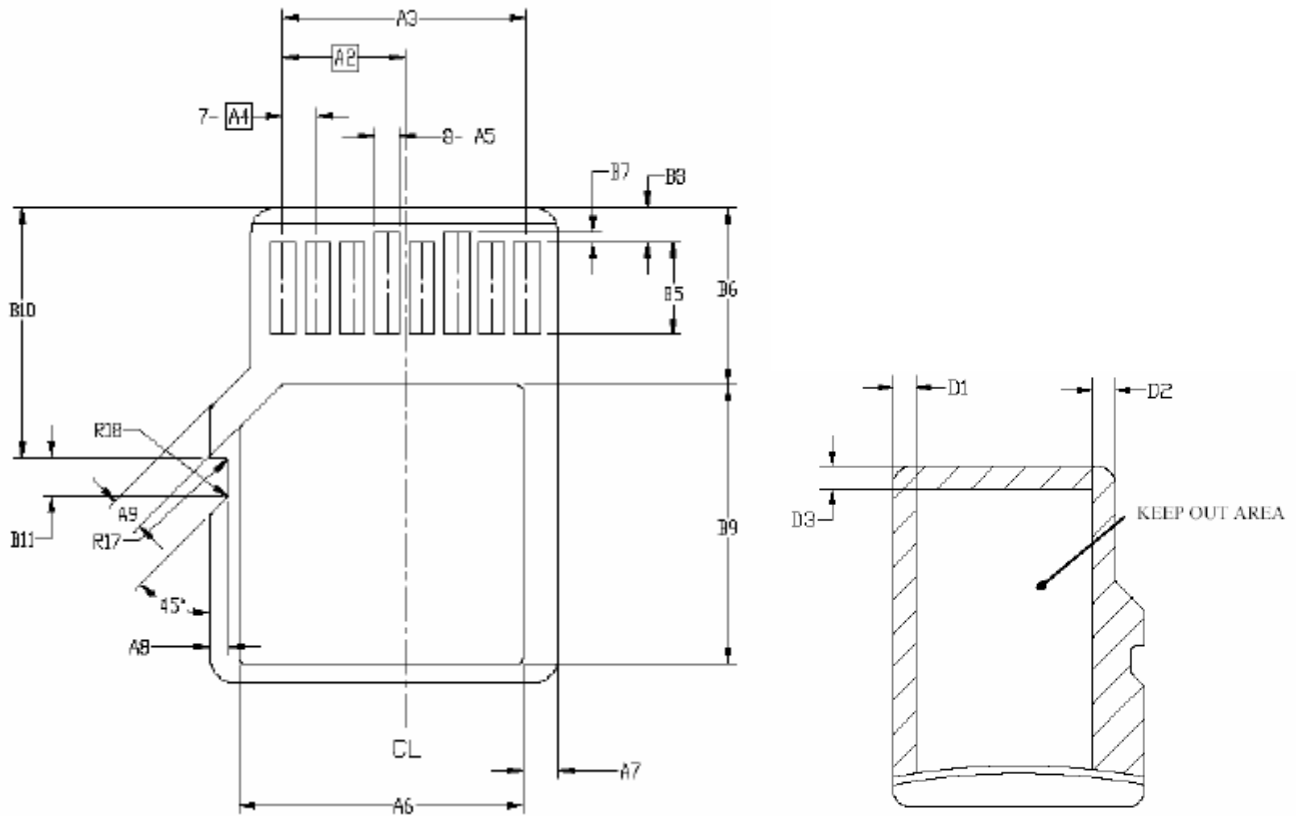

Figure 2. microSD Bottom View and Keep Out Area

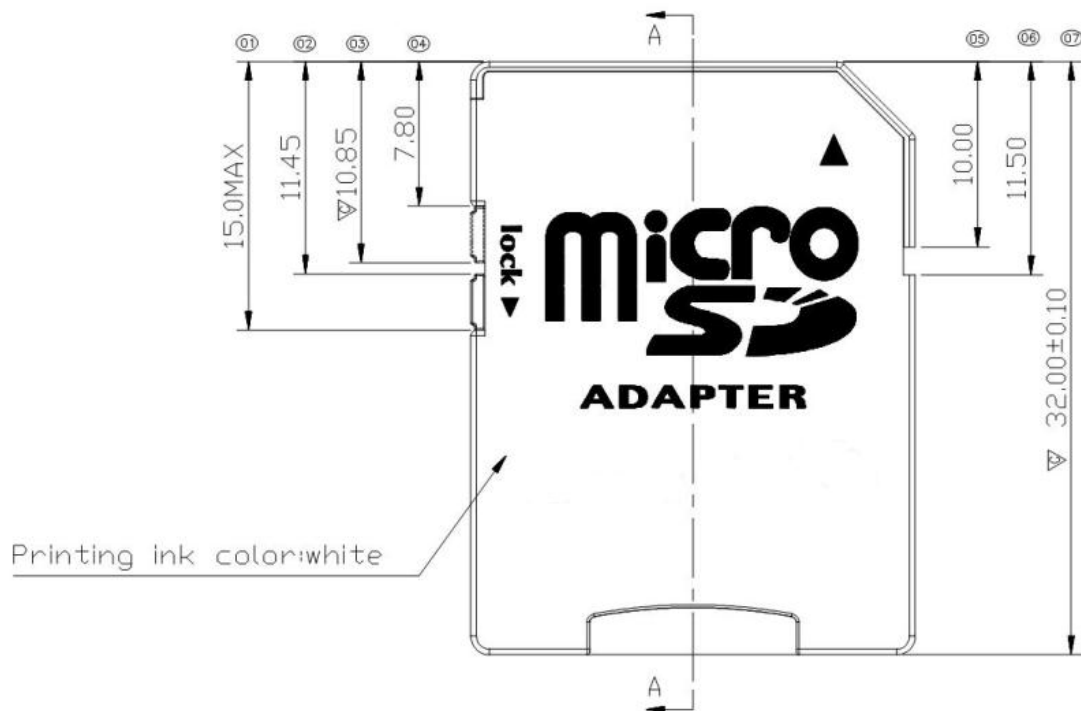

Figure 3. microSD Adapter Top View

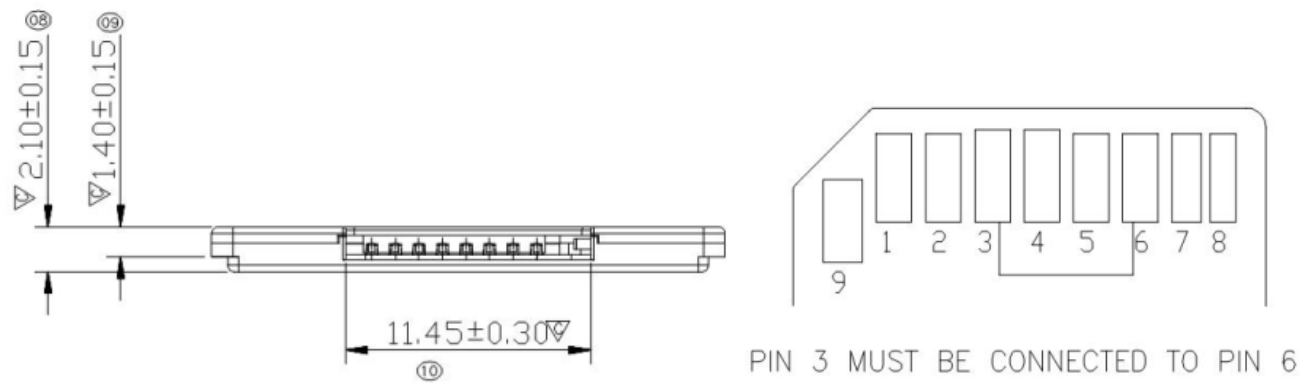

Figure 4. microSD Adapter Contacts

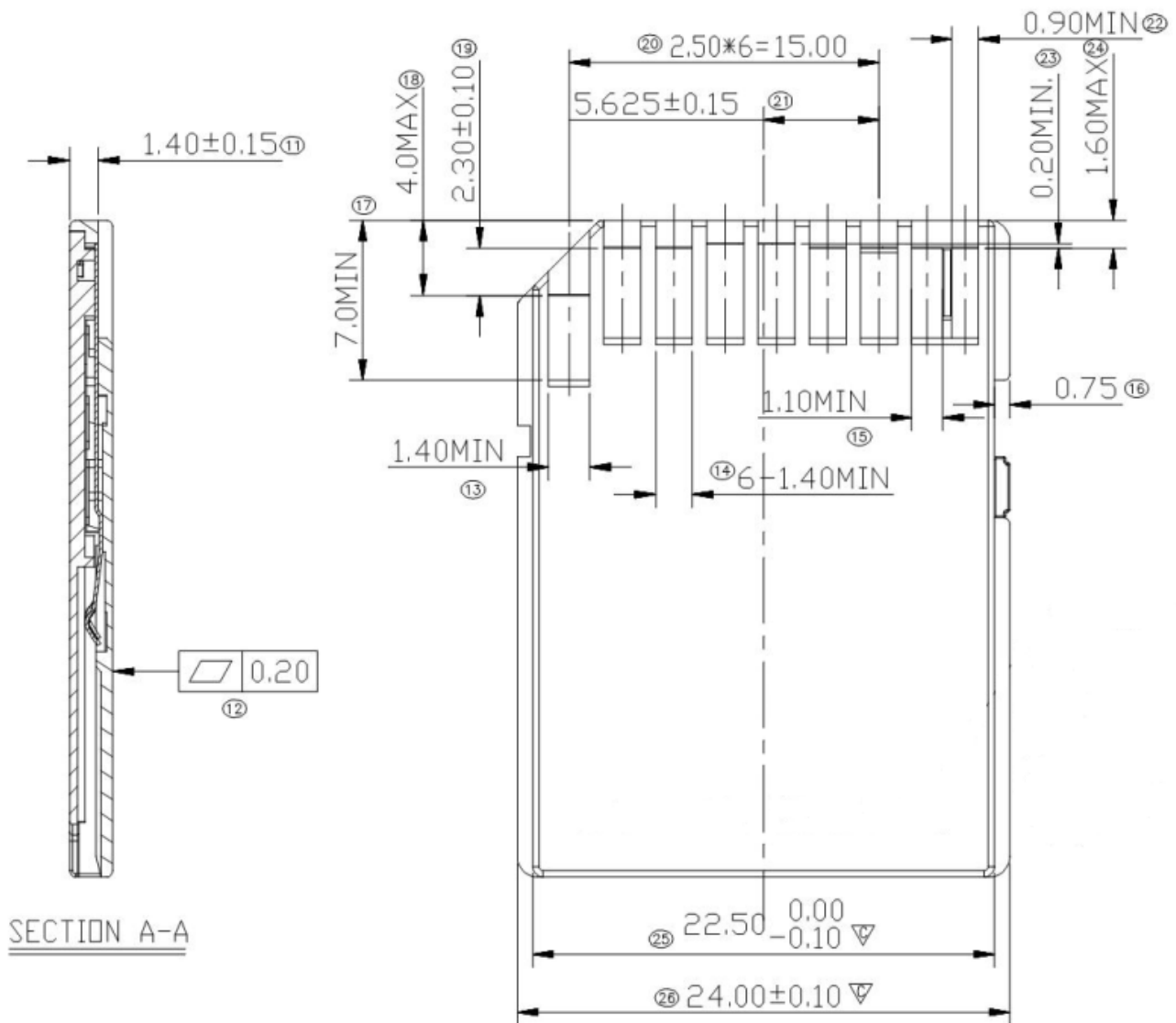

Figure 5. microSD Adapter Bottom and Side Views

Table 6. microSD Memory Card Package - Dimensions

SYMBOL	COMMON DIMENSIONS ¹			NOTE
	MIN ²	NOM ²	MAX ²	
A	10.90	11.00	11.10	
A1	9.60	9.70	9.80	
A2	-	3.85	-	BASIC
A3	7.60	7.70	7.80	
A4	-	1.10	-	BASIC
A5	0.75	0.80	0.85	
A6	-	-	8.50	
A7	0.90	-	-	
A8	0.60	0.70	0.80	
A9	0.80	-	-	
B	14.90	15.00	15.10	
B1	6.30	6.40	6.50	
B2	1.64	1.84	2.04	
B3	1.30	1.50	1.70	
B4	0.42	0.52	0.62	
B5	2.80	2.90	3.00	
B6	5.50	-	-	
B7	0.20	0.30	0.40	
B8	1.00	1.10	1.20	
B9	-	-	9.00	
B10	7.80	7.90	8.00	
B11	1.10	1.20	1.30	
C	0.90	1.00	1.10	
C1	0.603	0.703	0.803	
C2	0.20	0.30	0.40	
C3	0.00	-	0.15	
D1	1.00	-	-	
D2	1.00	-	-	

SYMBOL	COMMON DIMENSIONS ¹			NOTE
	MIN ²	NOM ²	MAX ²	
D3	1.00	-	-	
R1	0.20	0.40	0.60	
R2	0.20	0.40	0.60	
R3	0.70	0.80	0.90	
R4	0.70	0.80	0.90	
R5	0.70	0.80	0.90	
R6	0.70	0.80	0.90	
R7	29.50	30.00	30.50	
R10	-	0.20	-	
R11	-	0.20	-	
R17	0.10	0.20	0.30	
R18	0.20	0.40	0.60	
R19	0.05	-	0.20	

Notes:

1. Dimensions are in millimeters.
2. Dimensioning and tolerances per ASME Y14.5M-1994.
3. Coplanarity is additive to C1 max thickness.

3 microSD Card System Concept

The microSD Card provides application designers with a low-cost mass storage device, implemented as a removable card that supports a high security level for content protection, and a compact, easy-to-implement interface. microSD Memory Cards can be grouped into several card classes that differ in the functions they provide (defined by the subset of microSD Memory Card system commands supported by the class).

A microSD Card system includes the microSD Card (or several cards), the bus (SD or SPI), and the Host/Application. Host and Application specifications are beyond the scope of this document. The following sections provide an overview of the card, bus topology, and communication protocols of the microSD Card system. The content protection (security) system description is provided in a separate document.

3.1 Rewritable or Read-only Memory Cards

microSD Memory Cards are available in two formats, as determined by the card manufacturer:

- * **Read/Write (RW) card** — (Flash: One Time Programmable – OTP, Multiple Time Programmable – MTP). These cards are typically sold as blank (empty) media and are used for mass data storage, end user video, and audio or digital image recording.
- * **Read Only Memory (ROM) card** — ROM cards are manufactured with fixed data content, and are typically used as media for distribution of software, audio, or video content.

3.2 Card Capacity

Two types of microSD Memory Cards are available, differentiated by memory capacity:

- * **Standard Capacity** — microSD Memory Card supports capacities up to and including 2GB. All versions of the Physical Specifications define the Standard Capacity microSD Memory Card.
- * **High Capacity** — microSDHC Memory Card supports capacities more than 2GB (231 bytes) and this version of the specification limits capacity up to and including 32GB. The High Capacity SDHC Memory Card is recently defined in the “Physical Layer Specification, Version 2.00.”

Only hosts that are compliant to the Physical Layer Specification version 2.00 or higher and the microSD File System Specification Version 2.00 can access High Capacity microSDHC Memory Cards. Other hosts fail to initialize High Capacity microSDHC Memory Cards.

- Notes:**
1. The Part 1 Physical Layer Specification Version 2.00 and Part 2 File System Specification Version 2.00 allow Standard Capacity microSD Memory Cards to have capacity up to and including 2GB and High Capacity SDHC Memory Cards to have capacity up to and including 32GB. microSDXT Memory Cards with a capacity greater than 32GB will be available with updated versions of Part 1 and Part 2 Specifications.
 2. Hosts that can access (read and/or write) SD Memory Cards with a capacity greater than 2GB and up to and including 32GB, shall also be able to access microSD Memory Cards with a capacity of 2GB or less.

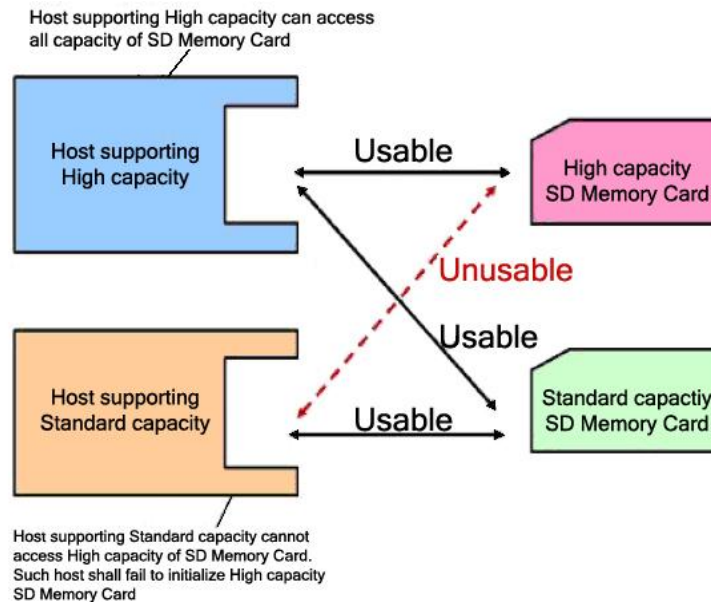

Figure 6. Host/Card Usability

Two types of High Capacity microSDHC Memory Card are specified:

Type A (Single State Card) — This card type has a single High Capacity memory area. Details of Type A are specified in the Physical Layer Specification version 2.00.

Type B (Dual State Card) — This card type has both High Capacity memory areas and Standard Capacity memory areas. In Type B cards, only one memory area can be used at any given time. A mechanical switch is used to select the desired memory area. Details of Type B will be defined in future specifications. It is not necessary for the host to distinguish card types.

3.3 Speed Class

The Secure Digital Association defines a series of *Speed Class Rating* numbers as the official speed measurement for SD cards. The class numbers and their associated performance specifications are shown below:

- * **Class 0** — This card class does not specify performance. Class 0 includes all the legacy cards prior to this specification, regardless of performance.
- * **Class 2** — equal or greater than 2 MB/s.
- * **Class 4** — equal or greater than 4 MB/s.
- * **Class 6** — equal or greater than 6 MB/s.
- * **Class 10** — equal or greater than 10 MB/s.

Delkin's High Capacity SDHC Memory Cards have a performance rating of Class 6 or higher.

Note: The unit of performance [MB/sec] indicates 1000x1000 [Bytes/sec] while the unit of data size [MB] indicates 1024x1024 [Bytes]. This is because the maximum SD Bus speed is specified by the maximum SD clock frequency (25 [MB/sec] = 25000000 [Bytes/sec] at 50 MHz) and data size is based on memory boundary (power of 2).

3.4 Command System

microSD commands `CMD34–37`, `CMD50`, and `CMD57` are reserved for microSD command system expansion via the `switch` command. Switching between the various functions of the command system function group will change the interpretation and associated bus transaction of these commands (i.e., command without data transfer, single block read, and multiple block write). A supporting command system is optional.

- * When the "standard command set" (default function 0x0) is selected, these commands will not be recognized by the card and will be considered as illegal commands (as defined in Version 1.01 of the microSD Physical Layer Specification).
- * When the "vendor specific" (function 0xE) is selected, the behaviors of these commands are vendor specific. They are not defined by this standard and may change for different card vendors.
- * When the "mobile e-commerce" (function 0x1) is selected, the behavior of these commands is governed by the microSD Specifications Part A1: Mobile Commerce Extension Specification.

When either of these extensions is used, special care should be given to proper selection of the command set function. Otherwise, the host command may be interpreted incorrectly.

All other commands of the microSD Memory Card (not reserved for the switch commands) are always available and will be executed as defined in this document regardless of the currently-selected command set.

3.4.1 Send Interface Condition Command (CMD8)

`CMD8` (Send Interface Condition Command) is used to initialize SD Memory Cards, compliant to the Physical Specification Version 2.00. `CMD8` is valid when the card is in idle state. This command has two functions:

- * **Voltage check** — Checks whether the card can operate on the host supply voltage.
- * **Enables expansion of existing command and response** — Reviving `CMD8` enables expanded functionality to some of the existing commands by redefining previously reserved bits. For example, `ACMD41` is expanded to support initialization of High Capacity SDHC Memory Cards.

Table 7. CMD8 Format Description

Bit position	47	46	[45:40]	[39:20]	[19:16]	[15:8]	[7:1]	0
Width (bits)	1	1	6	20	4	8	7	1
Value	'0'	'1'	'001000'	'00000h'	X	X	X	'1'
Description	Start bit	Transmission bit	Command index	Reserved bits	Voltage supplied (VHS)	Check pattern	CRC7	End bit

Voltage Supplied	Value Definition
0000b	Not Defined
0001b	2.7-3.6V
0010b	Reserved for Low Voltage Range
0100b	Reserved
1000b	Reserved
Others	Not Defined

When the card is in an Idle state, the host shall issue CMD8 before ACMD41. In the argument, “voltage supplied” is set to the host supply voltage and ‘check pattern’ is set to any 8-bit pattern. The card checks to determine whether it can operate on the host’s supply voltage. The card that accepted the supplied voltage returns an R7 response. In the response, the card echoes back both the voltage range and check pattern set in the argument. If the card does not support the host supply voltage, it shall not return response and stays in Idle state. Table 8 shows the card operation for CMD8.

Table 8. CMD8 Card Operation

Command Argument Check					Response of Card ¹					
Index	Reserved	VHS	Pattern	CRC	Index	Ver	Reserved	VCA	Pattern	CRC
Don't Care	Don't Care	Don't Care	Don't Care	Error	No Response (CRC Error Indication in the following command)					
Not 8	Don't Care	Don't Care	Don't Care	Correct	Depends on command index					
=8	Don't Care	Mismatch2	Don't Care	Correct	No Response					
=8	Don't Care	Match2	Don't Care	Correct	8	Ver=0	0	Echo Back	Echo Back	Calculate

- Notes:**
1. Response indicates the actual response the card returns. (Does not include errors during response transfer.)
 2. Match means AND for conditions a and b below. Mismatch is other cases.
 - a. Only one bit is set to 1 in VHS.
 - b. Card supports the host’s supply voltage.

3.4.2 Command Functional Difference in High Capacity microSDHC Memory Card

Memory access commands include block read commands (CMD17, CMD18), block write commands (CMD24, CMD25), and block erase commands (CMD32, CMD33). Following are the functional differences between Standard Capacity and High Capacity SDHC Memory Card memory access commands:

* **Command Argument**

- In High Capacity Cards, the 32-bit argument of memory access commands uses the memory address in block address format. Block length is fixed to 512 bytes.
- In Standard Capacity Cards; the 32-bit argument of memory access commands uses the memory address in byte address format. Block length is determined by CMD16, for example:
 - Argument 0001h is byte address 0001h in the Standard Capacity Card and 0001h block in the High Capacity Card.
 - Argument 0200h is byte address 0200h in the Standard Capacity Card and 0200h block in the High Capacity Card.

* **Partial Access and Misalign Access**

Partial access and Misalign access (crossing physical block boundary) are disabled in High Capacity card as the block address is used. Access is only granted based on block addressing.

* **Set Block Length**

When memory read and write commands are used in block address mode, 512-byte fixed block length is used, regardless of the block length set by CMD16. The setting of the block length does not affect the memory access commands. CMD42 is not classified as a memory access command.

Data block size shall be specified by CMD16, and the block length can be set up to 512 bytes. Setting block length larger than 512 bytes sets the BLOCK_LEN_ERROR error bit regardless of the card capacity.

* **Write Protected Group**

The High Capacity SDHC Memory Card does not support write-protected groups. Issuing CMD28, CMD29, and CMD30 generates the ILLEGAL_COMMAND error.

4 microSD Card Interface

The Interface descriptions provided in this section locates the position and orientation of microSD Memory Card contact surfaces (pins) and provides relevant dimensions.

4.1 Pin Assignments

Figure 7 shows the location of the microSD Memory Card pins.

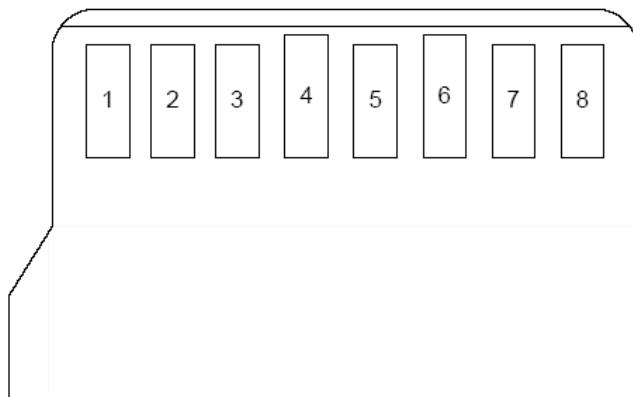

Figure 7. microSD Contacts

4.2 Pin Functions

Table 9 provides the name, type, and function of the microSD Memory Card pins for both the SD and SPI modes.

Table 9. microSD Memory Card Pin Assignments

Pin#	SD Mode			SPI Mode		
	Name	Type ¹	Description	Name	Type	Description
1	DAT2	I/O/PP	Data Line[Bit2]	RSV		
2	CD/DAT32	I/O/PP3	Card Detect/Data Line [Bit3]	CS	I	Chip Select (negative true)
3	CMD	PP	Command/Response	DI	I	Data in
4	Vdd	S	Supply voltage	Vdd	S	Supply voltage
5	CLK	I	Clock	SCLK	I	Clock
6	Vss	S	Supply voltage ground	Vss	S	Supply voltage ground
7	DAT0	I/O/PP	Data Line [Bit0]	D0	O/PP	Data Out
8	DAT1	I/O/PP	Data Line [Bit1]	RSV		

Notes: 1. **S** = power supply; **I** = input; **O** = output using push-pull drivers; **PP** = I/O using

push-pull drivers

2. The extended DAT line (DAT1-DAT3) are input on power up and start to operate as DAT lines after the SET_BUS_WIDTH command. The Host shall keep its own DAT1-DAT3 lines in input mode, as well, while they are not used. This is done in order to keep compatibility to Multimedia Cards.
3. After power up, this line is input with 50KΩ pull-up (can be used for card detection or SPI mode selection). The pull-up should be disconnected by the user, during regular data transfer, with the SET_CLR_CARD_DETECT (ACMD42) command.

4.3 SD Bus Topology

The microSD Card system defines two alternative communication protocols: microSD and SPI. Applications can choose either mode. Mode selection is transparent to the host. The card automatically detects the mode of the reset command and will expect all further communication to be in the same communication mode. Therefore, applications that use any one communication mode do not have to be aware of the other.

4.3.1 microSD Bus Mode Protocol

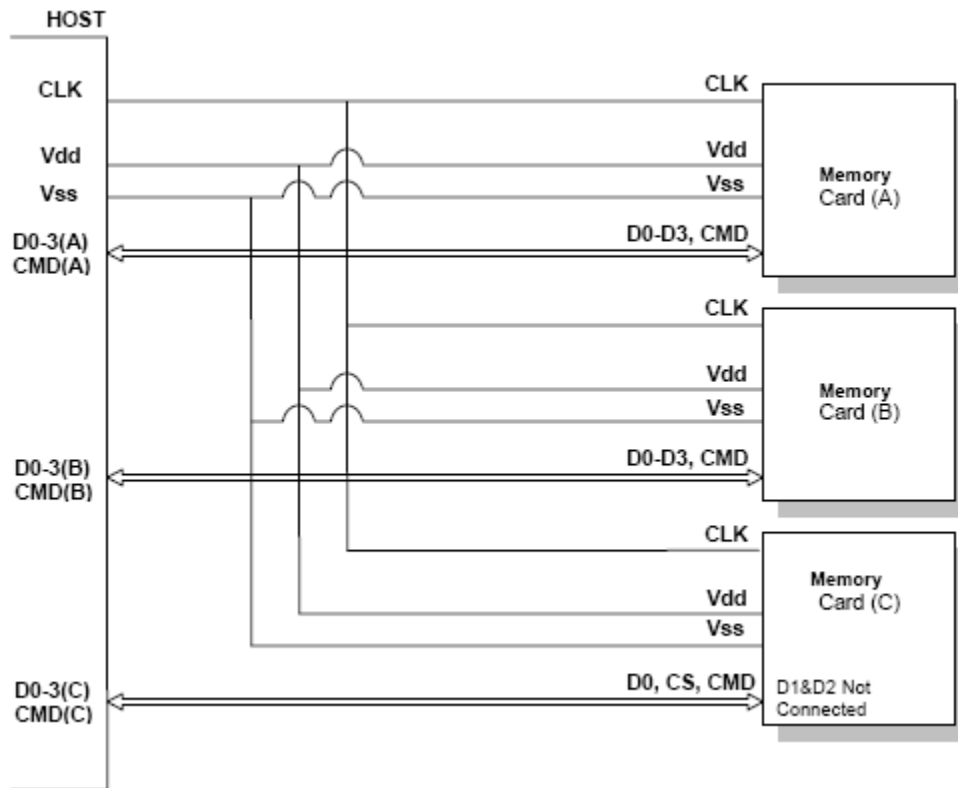

Figure 8. microSD Memory Card System Bus

The microSD bus includes the following signals:

- * **CLK** — Host to card clock signal

- * **CMD** — Bi-directional Command/Response signals
- * **DAT0 - DAT3** — Four bi-directional data signals
- * **VDD, VSS1, and VSS2** — Power and ground signals

The microSD Memory Card bus has a signal master (application), multiple slaves (cards), synchronous star topology (see Figure 5). Clock, power, and ground signals are common to all cards. Command (CMD) and data (DAT0 - DAT3) signals are dedicated to each card providing continuous point to point connection to all the cards.

During initialization, process commands are sent to each card individually, allowing the application to detect the cards and assign logical address to the physical slots. Data is always sent (received) to (from) each card individually. However, in order to simplify the handling of the card stack, after the initialization process, all commands may be sent concurrently to all cards. Addressing information is provided in the command packet.

microSD bus allows dynamic configuration of the number of data lines. After power up, by default, the microSD Memory Card will use only DAT0 for data transfer. After initialization the host can change the bus width (number of active data line). This feature allows easy tradeoff between HW cost and system performance.

Note: While DAT1-DAT3 are not in use, the related Host's DAT lines should be in tri-state (input mode).

4.3.2 SPI Bus Mode Protocol

The SPI compatible communication mode of the SD Memory Card is designed for communication with a SPI channel, commonly found in various microcontrollers in the market. The interface is selected during the first reset command after power up and cannot be changed as long as the part is powered on.

The SPI standard defines the physical link only, and not the complete data transfer protocol. The SD Memory Card SPI implementation uses the same command set of the SD mode. From the application point of view, the advantage of the SPI mode is the capability of using an off-the-self host, hence reducing the design-in effort to a minimum. The disadvantage is the loss of performance, relative to the SD mode which enables the wide bus option. The SD Memory Card SPI interface is compatible with SPI hosts available on the market.

As any other SPI device, the SD Memory Card SPI channel consists of the following four signals:

- * **CS** — Host to card Chip Select signal
- * **CLK** — Host to card clock signal
- * **DataIn** — Host to card data signal
- * **DataOut** — Card to host data signal

Another SPI common characteristic is byte transfer, which is implemented in the card as well. All data tokens are multiples of byte (8-bit) and are always byte-aligned to the CS signal.

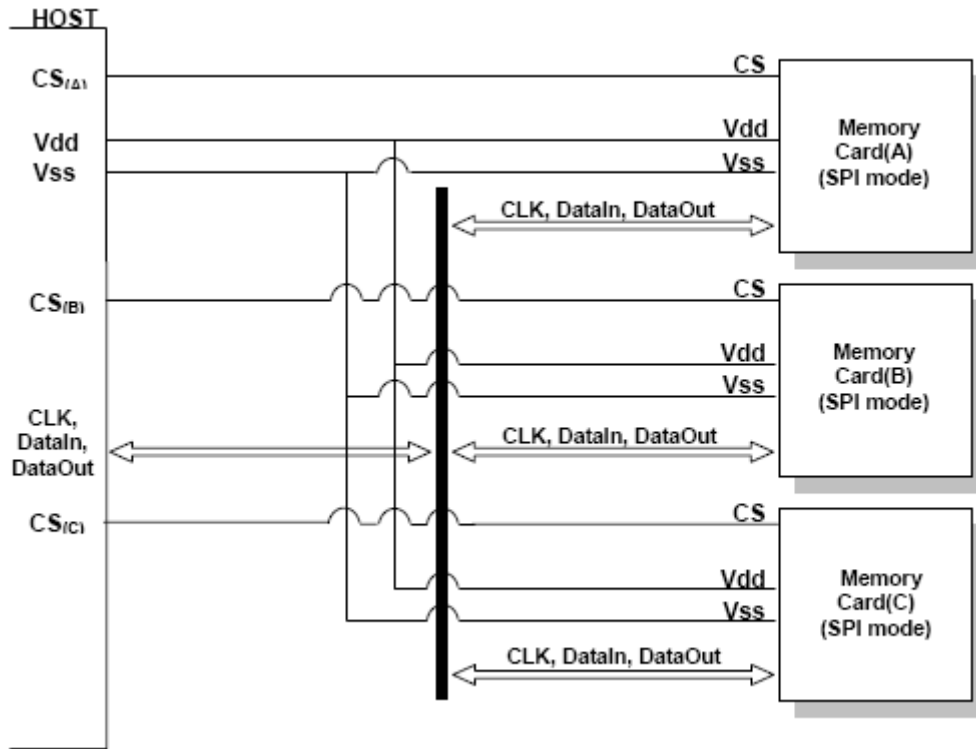

Figure 9. microSD Memory Card SPI System Bus

Card identification and addressing methods are replaced by a hardware Chip Select (CS) signal. There are no broadcast commands. For every command, a card (slave) is selected by asserting (active low) the CS signal (see Figure 8).

The SPI interface uses 6 of the 8 SD bus signals (DAT1 and DAT2 are not used, DAT3 is the CS signal.) of the SD bus.

5 Read and Write Operations

5.1 microSD Bus Protocol

5.1.1 Command

A command is a token which starts an operation. Commands are sent from the host either to a single card (addressed command) or to all connected cards (broadcast command). Commands are transferred serially on the `CMD` line.

5.1.2 Response

A response is a token, which is sent from an addressed card, or (synchronously) from all connected cards to the host as an answer to a received command. Responses are transferred serially on the `CMD` line.

5.1.3 Data

Data can be transferred from the card to the host or vice versa. Data is transferred via the `DAT` line.

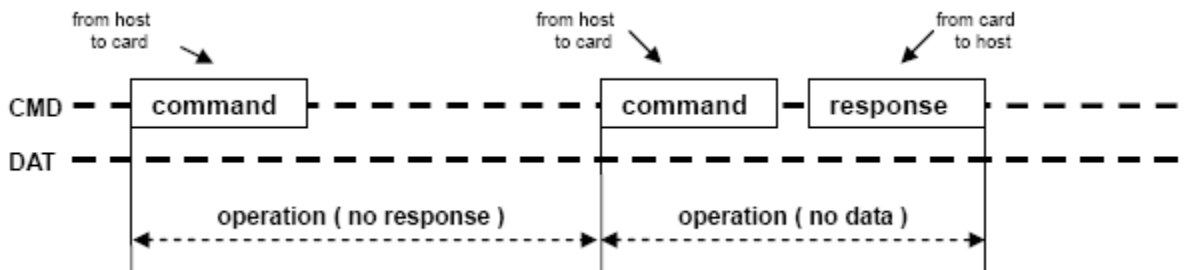

Figure 10. “no response” and “no data” Operations

The basic transaction transfers information directly within the command or response structure. In addition, some operations have a data token.

Data transfer to/from the SD memory card is done in blocks, always succeeded by CRC bits. Single and multiple block operations are defined. Note that the Multiple Block operation mode is better for faster write operation. A multiple block transmission is terminated when a `STOP` command follows on the `CMD` line. Data transfer can be configured by the host to use single or multiple data lines.

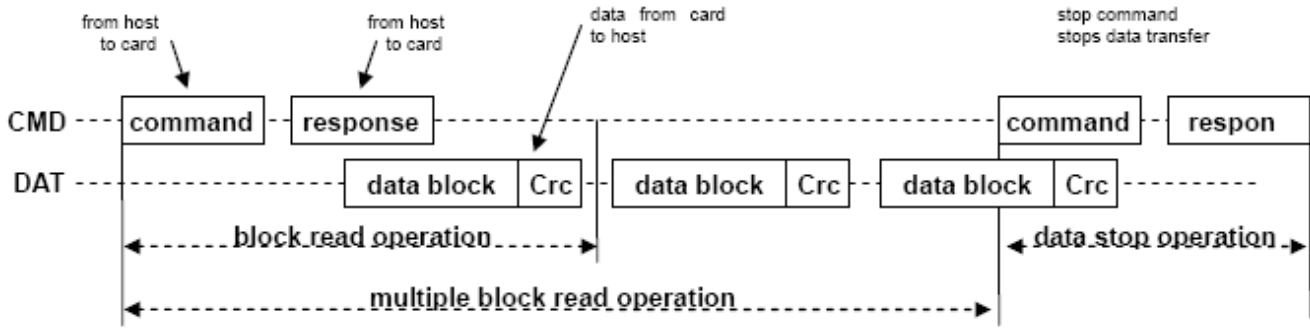

Figure 11. Multiple Block Read Operation

The block write operation uses a simple busy signaling of the write operation duration on the DAT0 data line (see Figure 12), regardless of the number of data lines used for transferring the data.

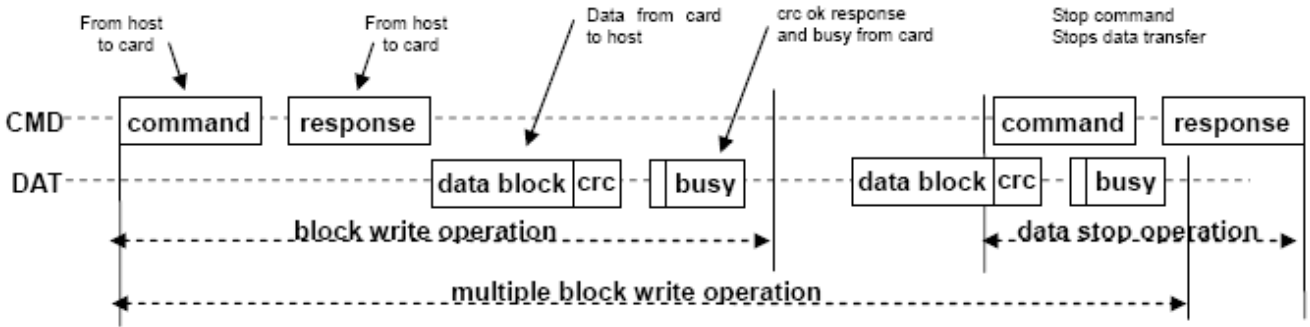

Figure 12. Multiple Block Write Operation

Command tokens use the coding scheme shown below:

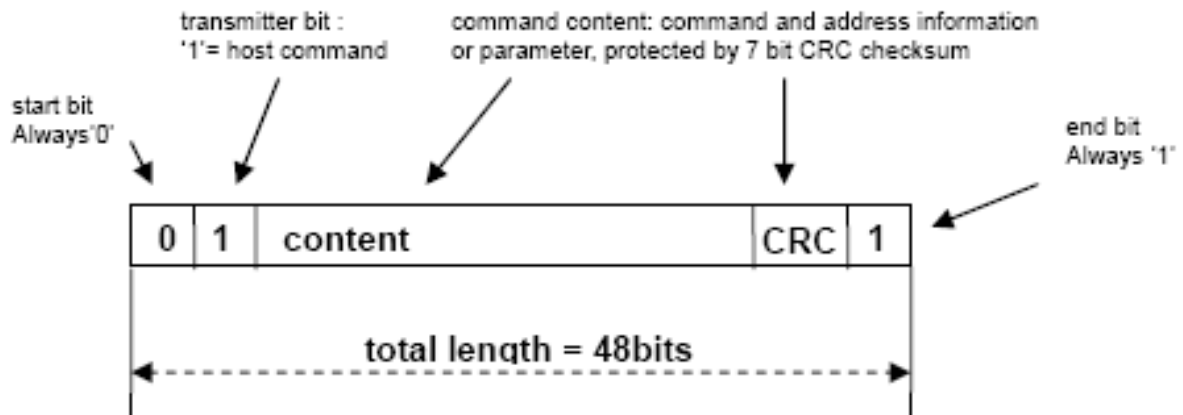

Figure 13. Command Token Format

Each command token is preceded by a start bit and succeeded by an end bit. The total length is 48 bits.

Each token is protected by CRC bits so that transmission errors can be detected and operation may be repeated. Response tokens have four coding schemes, depending on their content. The token length is either 48 or 136 bits.

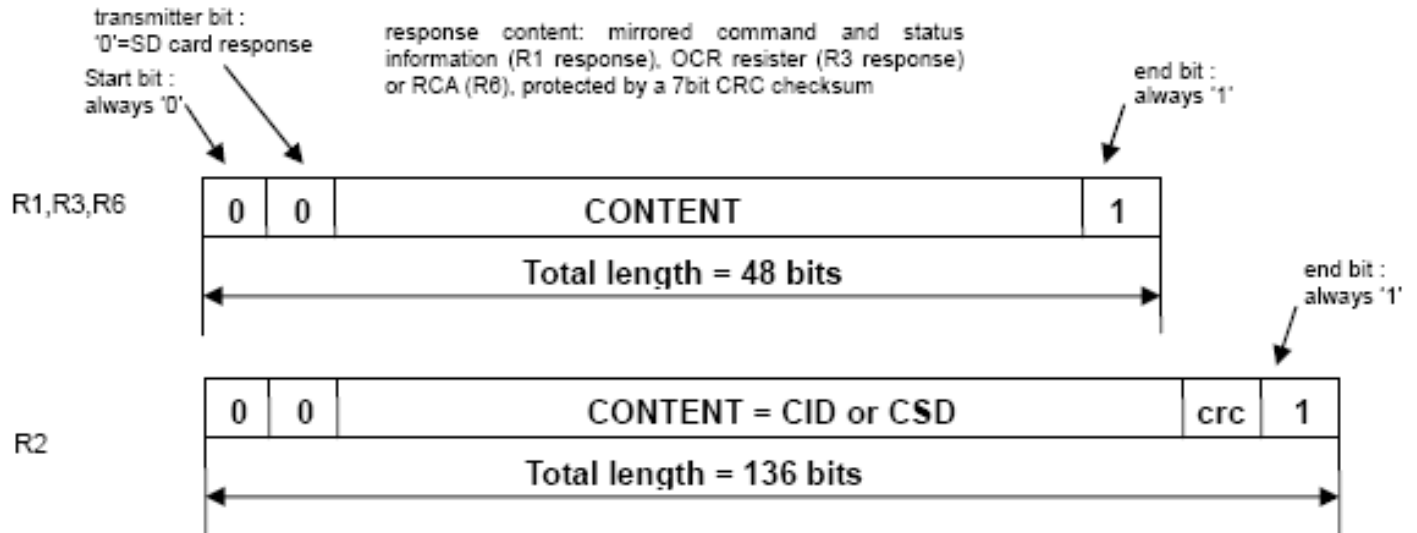

Figure 14. Response Token Format

In the CMD line, the MSB bit is transmitted first and the LSB bit is the last.

When the Wide Bus option is used, the data is transferred 4 bits at a time (see Figure 15). Start when the end bits, as well as the CRC bits are transmitted for every one of the DAT lines. CRC bits are calculated and checked for every DAT line individually. The CRC status response and busy indication will be sent by the card to the host on DAT0 only. (DAT1-DAT3 during that period are “don’t care.”)

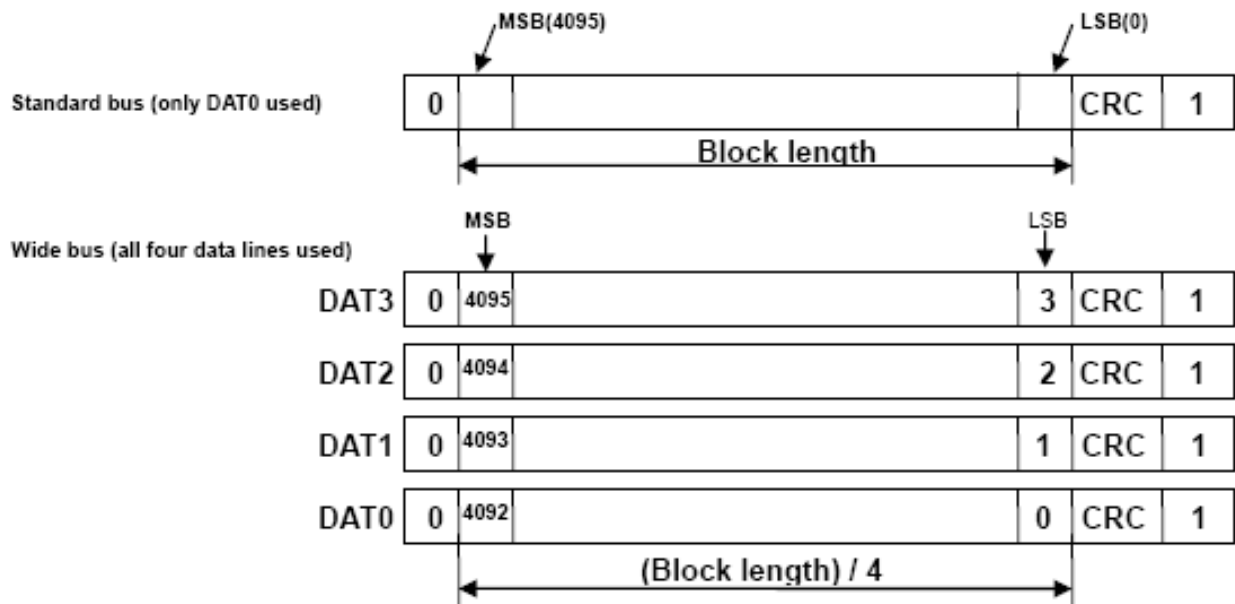

Figure 15. Data Packet Format

5.2 SPI Bus Protocol

While the microSD Channel is based on command and data bit streams which are initiated by a start bit and terminated by a stop bit, the SPI channel is byte oriented.

5.2.1 Command

Every command or data block is built of 8-bit bytes and is byte aligned to the CS signal (i.e., the length is a multiple of 8 clock cycles).

5.2.2 Response

The response behavior in the SPI mode differs from the SD mode in the following three aspects:

- * The selected card always responds to the command.
- * Two new (8- and 16-bit) response structures are used.
- * When the card encounters a data retrieval problem, it will respond with an error (which replaces the expected data block) rather than returning a time-out, as in the SD mode.

In addition to the command response, every data block sent to the card during write operations will be acknowledged with a special data response token.

5.2.3 Data Read

Single and multiple blocks read commands are supported in SPI mode. However, in order to comply with the SPI industry standard, only two (unidirectional) signals are used. Upon reception of a valid read command the card will respond with a response token followed by a data token of the length defined in a previous `SET_BLOCKLEN (CMD16)` command. A multiple block read operation is terminated, similar to the SD protocol, with the `STOP_TRANSMISSION` command.

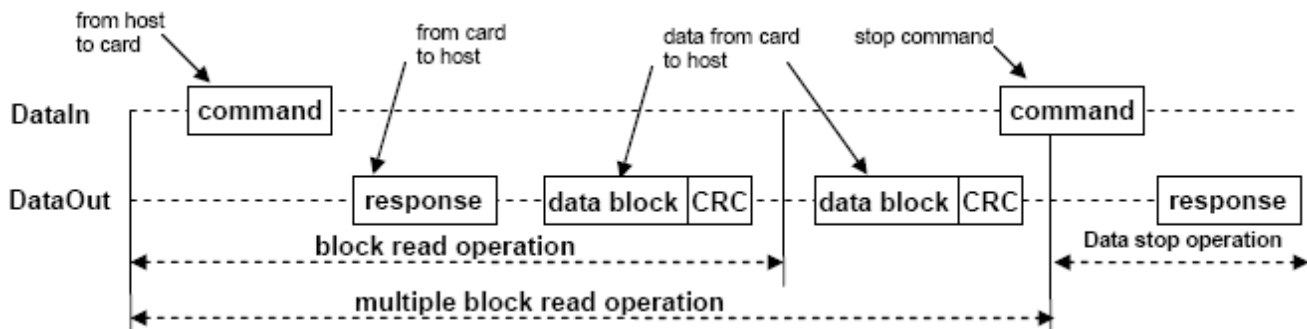

Figure 16. Read Operation

A valid data block suffixed with a 16 CRC generated by the standard CCITT polynomial $X^{16}+X^{12}+X^5+1$. In the case of data retrieval error, the card will not transmit any data. Instead, a special data error token will be sent to the host. Figure 17 shows a data read operation which terminated with an error token.

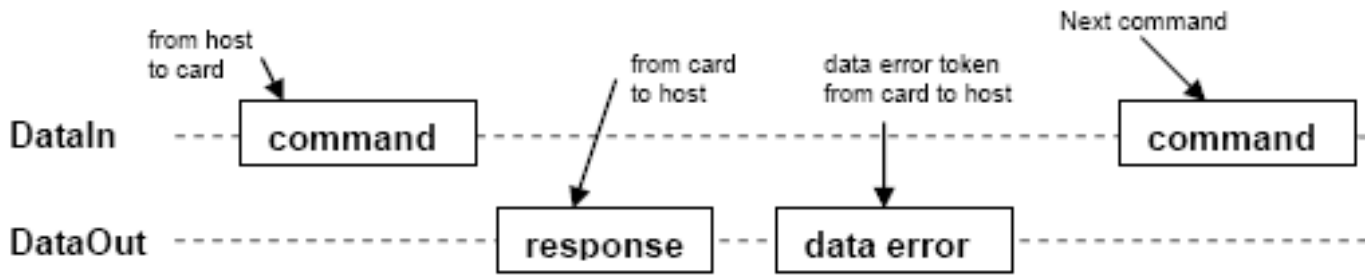

Figure 17. Read Operation – Data Error

Single and multiple block write operations are supported in SPI mode. Upon receipt of a valid write command, the card replies with a response token, and then waits for a data block to be sent from the host. CRC suffix, block length, and start address restrictions are identical to the read operation. (See Figure 17.)

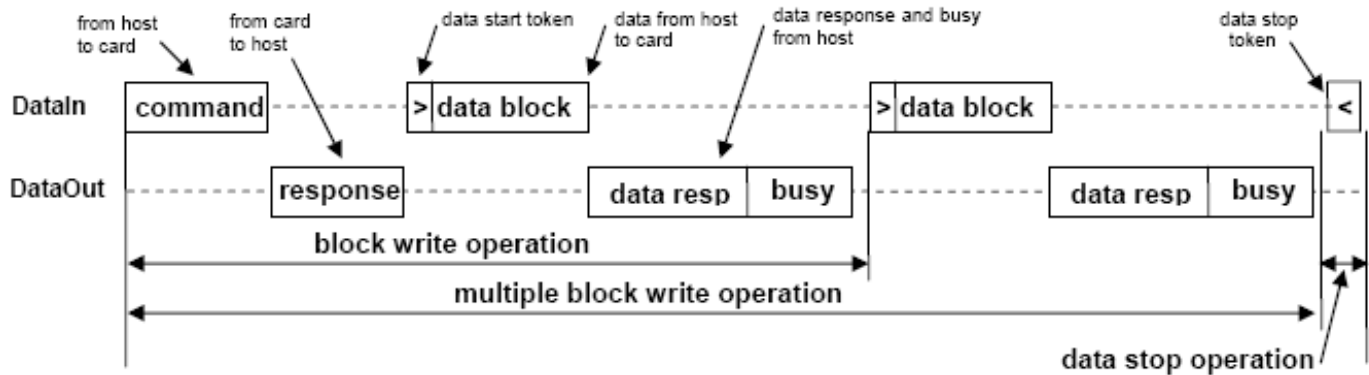

Figure 18. Write Operation

After a data block has been received, the card will respond with a data-response token. If the data block has been received without errors, it will be programmed. As long as the card is busy programming, a continuous stream of busy tokens will be sent to the host (effectively holding the Data Out line low).

5.3 Card Registers

Six registers are defined within the card interface: OCR, CID, CSD, RCA, DSR and SCR. These can be accessed only by corresponding commands. The OCR, CID, CSD and SCR registers carry the card- and content-specific information, while the RCA and DSR registers are configuration registers, storing actual configuration parameters.

In order to enable future extension, the card shall return 0 in the reserved register bits.

5.3.1 OCR Register

The 32-bit operation conditions register stores the voltage profile of the card. Additionally, this register includes status information bits. One status bit is set if the card power up procedure has been finished. This register includes another status bit indicating the card capacity status after set power up status bit. The OCR register shall be implemented by the cards.

The 32-bit operation conditions register stores the voltage profile of the card. Bit 7 of OCR is newly defined for Dual Voltage Card and set to 0 in default. If a Dual Voltage Card does not receive `CMD8`, OCR bit 7 in the response indicates 0, and the Dual Voltage Card which received `CMD8`, sets this bit to 1.

Additionally, this register includes two more status information bits.

- * **Bit 31** — Card power up status bit. This status bit is set if the card power up procedure has completed.
- * **Bit 30** — Card capacity status bit. This status bit is set to 1 if the card is High Capacity SDHC Memory Card. 0 Indicates that the card is Standard Capacity SD Memory Card. The Card Capacity status bit is valid after the card power up procedure is completed and the card power up status bit is set to 1. The Host shall read this status bit to identify a Standard or High Capacity SDHC Memory Card. The OCR register shall be implemented by the cards.

Table 10. OCR Register Definition

OCR bit position	OCR Fields Definition
0-3	Reserved
4	Reserved
5	Reserved
6	Reserved
7	Reserved for Low Voltage Range
8	Reserved
9	Reserved
10	Reserved
11	Reserved
12	Reserved
13	Reserved
14	Reserved
15	2.7-2.8
16	2.8-2.9
17	2.9-3.0
18	3.0-3.1
19	3.1-3.2
20	3.2-3.3
21	3.3-3.4
22	3.4-3.5
23	3.5-3.6
24-29	Reserved
30	Card Capacity Status (CCS) ¹
31	Card power up status bit (busy) ²

- Notes:** 1. This bit is valid only when the card power up status bit is set.
 2. This bit is set to **LOW** if the card has not finished the power up routine.

The supported voltage range is coded as shown in Table 10. A voltage range is not supported if the corresponding bit value is set to **LOW**. As long as the card is busy, the corresponding bit (31) is set to **LOW**.

5.3.2 CID Register

The Card Identification (CID) register is 128 bits wide. It contains the card identification information used during the card identification phase. Every individual Read/Write (RW) card shall have a unique identification number.

Table 11. CID Register Definition

Name	Field	Width	CID-slice
Manufacturer ID	MID	8	[127:120]
OEM/Application ID	OID	16	[119:104]
Product name	PNM	40	[103:64]
Product revision	PRV	8	[63:56]
Product serial number	PSN	32	[55:24]
Reserved	--	4	[23:20]
Manufacturing date	MDT	12	[19:8]
CRC7 checksum	CRC	7	[7:1]
Not used (always 1)	--	1	[0:0]

The structure of the CID register is defined as follows:

* **MID**

An 8-bit binary number that identifies the card manufacturer. The MID number is controlled, defined, and allocated to a SD Memory Card manufacturer by the SD-3C, LLC. This procedure is established to ensure uniqueness of the CID register.

* **OID**

A two-character ASCII string that identifies the card OEM and/or the card contents (when used as a distribution media either on ROM or FLASH cards). The OID number is controlled, defined, and allocated to an SD Memory Card manufacturer by the SD-3C, LLC. This procedure is established to ensure uniqueness of the CID register.

Note: SD-3C, LLC licenses companies that wish to manufacture and/or sell SD Memory Cards, including but not limited to flash memory, ROM, OTP, RAM, and SDIO Combo Cards. The SD-3C, LLC is a limited liability company established by Matsushita Electric Industrial Co. Ltd., SanDisk Corporation and Toshiba Corporation.

* **PNM**

The product name is a string, five-character ASCII string.

* **PRV**

The product revision is composed of two Binary Coded Decimal (BCD) digits, four bits each, representing an “n.m” revision number. The “n” is the most significant nibble and “m”

is the least significant nibble. For example, the PRV binary value field for product revision “6.2” will be 0110 0010b.

5.3.3 CSD Register

The Card-Specific Data register provides information regarding access to card contents. The CSD defines the data format, error correction type, maximum data access time, whether the DSR register can be used, etc. The programmable part of the register (indicated by R, W or W1, see Table 12 below) can be changed by CMD27.

5.3.4 CSD_STRUCTURE

Field structures of the CSD register differ, depending on the Physical Specification Version and Card Capacity. The CSD_STRUCTURE field in the CSD register indicates its structure version.

5.3.5 CSD Register (CSD Version 2.0)

Table 12 shows Definition of the CSD for the High Capacity SDHC Memory Card (CSD Version 2.0). This section describes the CSD fields and the relevant data types for the High Capacity SDHC Memory Card.

CSD Version 2.0 is applied to only the High Capacity SDHC Memory Card. The field name in parenthesis is set to fixed value and indicates that the host is not necessary to refer these fields. The fixed values enables host, which refers to these fields, to keep compatibility to CSD Version 1.0. The Cell Type field is coded as follows:

- * **R** — Readable
- * **W(1)** — Writable once
- * **W** — Writable multiple times

Table 12. CSD Register Fields (Version 2.0)

Name	Field	Width	Value	Cell Type	CSD-slice
CSD structure	CSD_STRUCTURE	2	01b	R	[127:126]
Reserved	-	6	00 0000b	R	[125:120]
Data read access-time	(TAAC)	8	0Eh	R	[119:112]
Data read access-time in CLK Cycles (NSAC*100)	(NSAC)	8	00h	R	[111:104]
Max. data transfer rate	(TRAN_SPEED)	8	32h or 5Ah	R	[103:96]
Card command classes	CCC	12	01x11011010 1b	R	[95:84]
Max. read data block length	(READ_BLK_LEN)	4	9	R	[83:80]
Partial blocks for read allowed	(READ_BLK_PARTIAL)	1	0	R	[79:79]
Write block misalignment	(WRITE_BLK MISALIGN)	1	0	R	[78:78]
Read block misalignment	(READ_BLK_MISALIGN)	1	0	R	[77:77]

Name	Field	Width	Value	Cell Type	CSD-slice
DSR implemented	DSR_IMP	1	x	R	[76:76]
Reserved	-	6	00 0000b	R	[75:70]
Device size	C SIZE	22	00 xxxxh	R	[69:48]
Reserved	-	1	0	R	[47:47]
Erase single block enable	(ERASE_BLK_EN)	1	1	R	[46:46]
Erase sector size	(SECTOR_SIZE)	7	7Fh	R	[45:39]
Write protect group size	(WP_GRP_SIZE)	7	0000000b	R	[38:32]
Write protect group enable	WP_GRP_ENABLE)	1	0	R	[31:31]
Reserved	-	2	00b	R	[30:29]
Write speed factor	(R2W_FACTOR)	3	010b	R	[28:26]
Max. write data block length	(WRITE_BL_LEN)	4	9	R	[25:22]
Partial blocks for write allowed	(WRITE_BL_PARTIAL	1	0	R	[21:21]
Reserved	-	5	00000b	R	[20:16]
File format group	(FILE_FORMAT_GRP)	1	0	R	[15:15]
Copy flag (OTP)	COPY	1	x	R/W(1)	[14:14]
Permanent write protection	PERM_WRITE_PROTECT	1	x	R/W(1)	[13:13]
Temporary write protection	TMP_WRITE_PROTECT	1	x	R/W	[12:12]
File format	(FILE_FORMAT)	2	00b	R	[11:10]
Reserved	-	2	00b	R	[9:8]
CRC	CRC	7	xxxxxxxh	R/W	[7:1]
Not used, value is always 1	-	1	1	-	[0:0]

CSD register fields are defined as follows:

* **TAAC**

This field is fixed on 0Eh, which indicates 1 ms. The host should not use TAAC, NSAC, and R2W_FACTOR to calculate timeout, and should use fixed timeout values for read and write operations.

* **NSAC**

This field is fixed to 00h. NSAC should not be used to calculate time-out values.

* **TRAN_SPEED**

Definition of this field is same as in CSD Version1.0.

* **CCC**

Definition of this field is same as in CSD Version1.0.

* **READ_BL_LEN**

This field is fixed to 9h, which indicates READ_BL_LEN=512 Byte.

*** READ_BL_PARTIAL**

This field is fixed to 0, which indicates partial block read is inhibited and only unit of block access is allowed.

*** WRITE_BLK_MISALIGN**

This field is fixed to 0, which indicates write access crossing physical block boundaries is always disabled in High Capacity SDHC Memory Cards.

*** READ_BLK_MISALIGN**

This field is fixed to 0, which indicates read access crossing physical block boundaries is always disabled in High Capacity SDHC Memory Cards.

*** DSR_IMP**

Definition of this field is same as in CSD Version 1.0.

*** C_SIZE**

This field is expanded to 22 bits and can indicate up to 2TB. This is the same as the maximum memory space specified by a 32-bit block address.

This parameter is used to calculate the user data area capacity in the SD Memory Card (not include the protected area). The user data area capacity is calculated from `C_SIZE` as follows:

$$\text{Memory capacity} = (\text{C_SIZE} + 1) \times 512\text{K bytes.}$$

As the maximum capacity of the Physical Layer Specification, Version 2.00 is 32GB; the upper six bits of this field shall be set to 0.

*** ERASE_BLK_EN**

This field is fixed to 1, which means the host can erase one or multiple units of 512 bytes.

*** SECTOR_SIZE**

This field is fixed to 7Fh, which indicates 64K bytes. This value does not relate to the erase operation. Version 2.00 cards indicate memory boundaries by AU size and this field should not be used.

*** WP_GRP_SIZE**

This field is fixed to 00h. The High Capacity SDHC Memory Card does not support write protected groups.

*** WP_GRP_ENABLE**

This field is fixed to 0. The High Capacity SDHC Memory Card does not support write protected groups.

*** R2W_FACTOR**

This field is fixed to 2h, which indicates 4 multiples. Write timeout can be calculated by multiplying the read access time and `R2W_FACTOR`. However, the host should not use this factor and should use 250 ms for write timeout.

*** WRITE_BL_LEN**

This field is fixed to 9h, which indicates `WRITE_BL_LEN=512` bytes.

*** WRITE_BL_PARTIAL**

This field is fixed to 0, which indicates partial block read is inhibited and only unit of block access is allowed.

*** FILE_FORMAT_GRP**

This field is set to 0. Host should not use this field.

*** COPY**

Definition of this field is same as in CSD Version 1.0.

*** PERM_WRITE_PROTECT**

Definition of this field is same as in CSD Version 1.0.

*** TMP_WRITE_PROTECT**

Definition of this field is same as in CSD Version 1.0.

*** FILE_FORMAT**

This field is set to 0. Host should not use this field.

*** CRC**

Definition of this field is same as in CSD Version 1.0.

*** RCA Register**

The writable 16-bit relative card address register carries the card address that is published by the card during the card identification. This address is used for the addressed host-card communication after the card identification procedure. The default value of the RCA register is `0x0000`. The value `0x0000` is reserved to set all cards into the Stand-by State with `CMD7`.

*** DSR Register (Optional)**

The 16-bit Driver Stage Register can be used to improve the bus performance for extended operating conditions (depending on parameters like bus length, transfer rate, or number of cards). The CSD register carries the information about the DSR register usage. The default value of the DSR register is `0x404`.

*** SCR Register**

In addition to the CSD register, there is another configuration register named SD CARD Configuration Register (SCR). SCR provides information on the SD Memory Card's special features that were configured into the given card. The size of SCR register is 64 bits. This register shall be set in the factory by the SD Memory Card manufacturer.

Table 13 describes the SCR register content.

Table 13. SCR Fields

Description	Field	Width	Cell Type	SCR Slice
SCR Structure	SCR_STRUCTURE	4	R	[63:60]
SD Memory Card – Spec. Version	SD_SPEC	4	R	[59:56]
Data_status_after erases	DATA_STAT_AFTER_ERASE	1	R	[55:55]
SD Security Support	SD_SECURITY	3	R	[54:52]
DAT Bus widths supported	SD_BUS_WIDTHS	4	R	[51:48]
Reserved	-	16	R	[47:32]
Reserved for manufacturer usage	-	32	R	[31:0]

Table 14. SCR Register Structure Versions

SCR_STRUCTURE	SCR Structure Version	SD Physical Layer Spec Version
D	SCR Version 1.0	Version 1.01 - 2.00
1-15	Reserved	

* **SD_SPEC**

Describes the Physical Layer Specification Version supported by the card.

Table 15. Physical Layer Specification Version

SD_SPEC	Physical Layer Specification Version Number
0	Version 1.0-1.01
1	Version 1.10
2	Version 2.00
3-15	Reserved

* **DATA_STAT_AFTER_ERASE**

Defines the data status after erase, whether it is 0 or 1, the status is card vendor dependent.

* **SD_SECURITY**

Describes the Security Specification Version supported by the card.

Table 16. SD-supported Security Algorithm

SD_SECURITY	Security Specification Version
0	No security
1	Not used
2	Version 1.01
3	Version 2.00
4-7	Reserved

Note that it is mandatory for a writable SD Memory Card to support Security Protocol. For ROM and OTP types of the SD Memory Card, this security feature is optional. In the case of the Standard Capacity SD Memory Card Version 1.01, this field shall be set to 2. For the High Capacity SDHC Memory Card, this field shall be set to 3.

* **SD_BUS_WIDTHS**

The following table describes all of the DAT bus widths that are supported by this card.

Table 17. SD Memory Card Supported Bus Widths

SD_BUS_WIDTHS	Supported Bus Widths
Bit 0	1 bit (DAT0)
Bit 1	Reserved
Bit 2	4 bit (DAT0-3)
Bit 3	Reserved

Since the SD Memory Card supports at least the two bus modes 1-bit or 4-bit width, then any SD card shall set at least bits 0 and 2 (SD_BUS_WIDTH=0101).