

DO NOT SCALE FROM THIS PRINT

DESIGNED & DIMENSIONED IN MILLIMETERS [INCHES]

SCPE-X-XX.XX-XX-X-XX

THIS PRODUCT MANUFACTURED WITH LEAD-FREE PROCESSING

PLATING SPECIFICATION
-G: .000050" GOLD ON CONTACT AREAS, NICKEL ON SHELLS

LENGTH
-XX.XX (IN METERS)
(FOR LENGTHS 05.00 METERS AND GREATER, -O OPTION IS REQUIRED)

POLARIZATION OPTION
-NP: NO POLARIZATION (ONLY MATES WITH SCRES-X-XX.XX-XX-C5E)

OUTDOOR OPTION
-O: OUTDOOR RATED

END OPTION
-D: DOUBLE ENDED (BOTH ENDS SEALED) (SEE FIG. 1, SHT. 1)
-S: SINGLE ENDED (ONE END SEALED) (SEE FIG. 2, SHT. 2)
-BC: BLUNT CUT (ONE END SEALED) (SEE FIG. 3, SHT. 3)

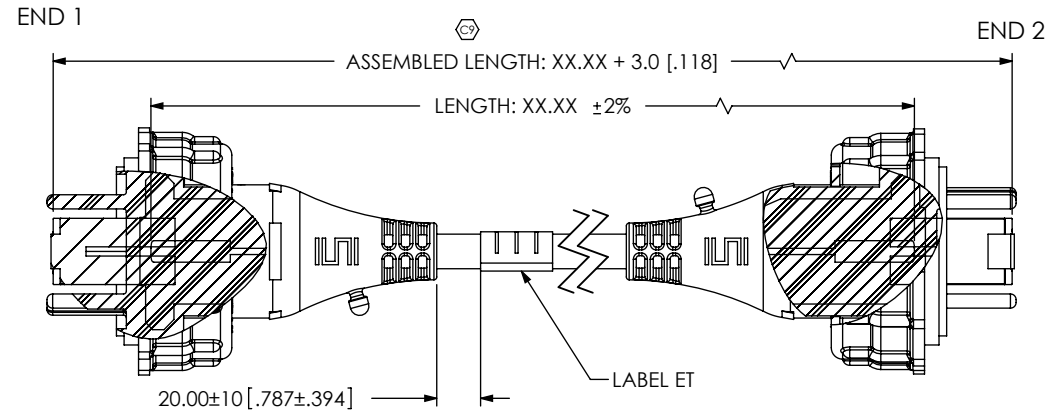

NOTE:
-02.00, -03.00, AND -05.00 ARE CATALOG STANDARD LENGTHS. FOR OTHER LENGTHS [0.25M[9.84] MIN - 5.00M[196.85] MAX] CONTACT SAMTEC.

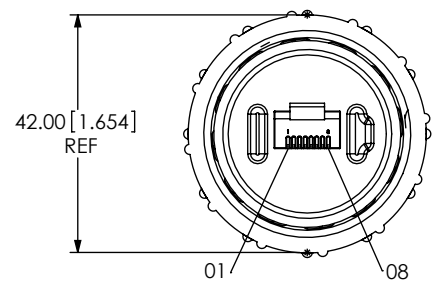
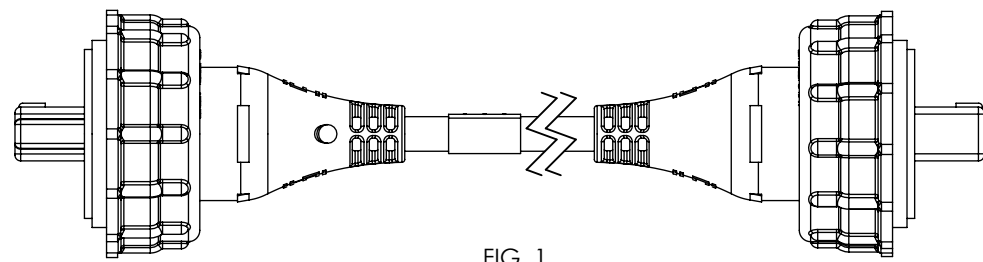
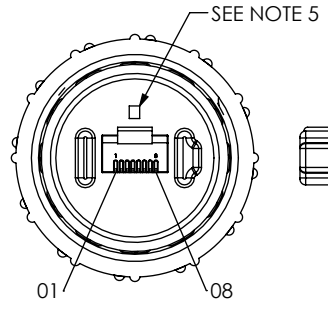

FIG. 1
SCPE-G-XX.XX-D SHOWN
(SEE SHEETS 4-6 FOR IN-PROCESS VIEWS)

- NOTES:
1. REPRESENTS A CRITICAL DIMENSION.
 2. NOTE DELETED.
 3. SAMTEC LOGO TO APPEAR ON SURFACE AS SHOWN, APPROXIMATELY 4.50[.177] x 7.50[.295], RAISED 0.25[.010].
 4. NOTE DELETED.
 5. ALL MULTIPLE CAVITY MOLDS SHALL IDENTIFY EACH CAVITY WITH A NUMBER DESIGNATION LOCATED WHERE SHOWN.
 6. ALL IDENTIFICATION MARKS SHALL NOT STAND GREATER THAN 0.05[.002] OFF THE SURFACE OF THE PART.
 7. MOLD TO BE INSERTED TO ACCEPT DIFFERENT CABLE DIAMETERS.
 8. ASSEMBLY TO BE 100% ELECTRICALLY TESTED TO CAT5E USING FLUKE DTX-1800 CABLE ANALYZER. AFTER FINAL ELECTRICAL TEST, LABEL EACH ASSEMBLY WITH 1 LABEL-ET.
 9. ALL EJECTOR PIN AND GATE LOCATIONS MUST BE APPROVED BY SAMTEC PRODUCT ENGINEERING.
 10. ANY ADDITIONAL VOIDING AND/OR MODIFICATIONS TO VOIDING MUST BE APPROVED BY SAMTEC PRODUCT ENGINEERING.
 11. ALL DRAFT MUST BE WITHIN THE SPECIFIED TOLERANCES.
 12. ALL INSIDE/OUTSIDE RADII 0.13 MAX UNLESS OTHERWISE STATED.
 13. NOTE DELETED
 14. NOTE DELETED.
 15. ASSEMBLY TO BE BULK PACKAGED.
 16. TORQUE SPECIFICATION FOR SCN-17-01 IS 12 IN-LBS
 17. NOTE DELETED.

UNLESS OTHERWISE SPECIFIED, DIMENSIONS ARE IN MILLIMETERS. TOLERANCES ARE: DECIMALS ANGLES X.X: ±0.35 [.014] X.XX: ±0.25 [.010] X.XXX: ±0.15 [.006]	PROPRIETARY NOTE THIS DOCUMENT CONTAINS INFORMATION CONFIDENTIAL AND PROPRIETARY TO SAMTEC, INC. AND SHALL NOT BE REPRODUCED OR TRANSFERRED TO OTHER DOCUMENTS OR DISCLOSED TO OTHERS OR USED FOR ANY PURPOSE OTHER THAN THAT WHICH IT WAS OBTAINED WITHOUT THE EXPRESSED WRITTEN CONSENT OF SAMTEC, INC.	520 PARK EAST BLVD, NEW ALBANY, IN 47150 PHONE: 812-944-6733 FAX: 812-948-5047 e-Mail: info@SAMTEC.com code 55322
MATERIAL: DO NOT SCALE DRAWING SHEET SCALE: 1:1.33333 INSULATOR: POLYCARBONATE CONTACTS: PHOS BRONZE SHELL: PHOS BRONZE SHIELD: PHOS BRONZE ETHERNET BOOT: PVC CABLE NUT: PA66 GF30 PREMOLD: TPE (Rf 640A) OVERMOLD: PA66 GF13 FR (70G13L); MAX REGRIND: 10% F:\DWG\MISC\MKTG\SCPE-X-XX.XX-XX-X-MKT.SLDDRW	MAX FLASH ALLOWED: .05[.002] MAX GATE VESTIGE: .05[.002]	DESCRIPTION: SEALED CIRCULAR CABLE PLUG, ETHERNET DWG. NO. SCPE-X-XX.XX-XX-X-XX BY: CHAD F 12/11/2004 SHEET 1 OF 11

FIG. 2
 SCPE-G-XX.XX-3 SHOWN
 (SEE SHEET 7-8 FOR IN-PROCESS VIEWS)
 (SAME AS FIG. 1, UNLESS OTHERWISE STATED)

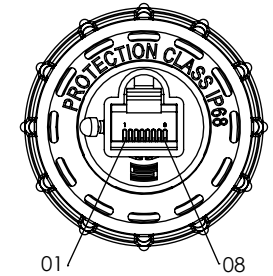
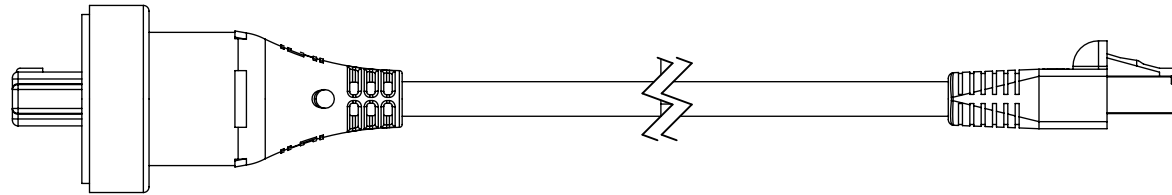
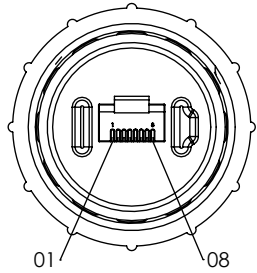
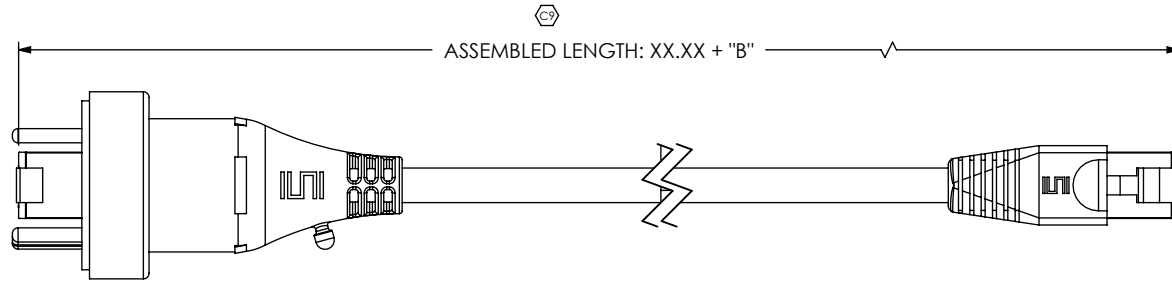
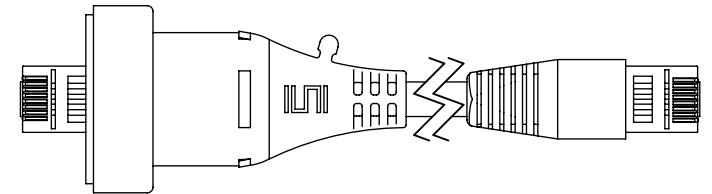
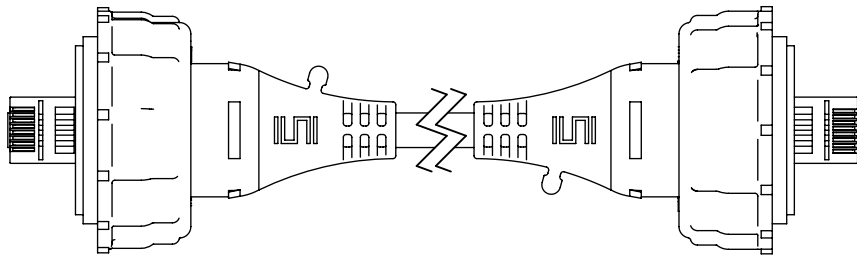

FIG. 4
 SCPE-G-XX.XX-D-NP SHOWN
 (SAME AS FIG. 1, UNLESS OTHERWISE STATED)

FIG. 5
 SCPE-G-XX.XX-3-NP SHOWN
 (SAME AS FIG. 2, UNLESS OTHERWISE STATED)



PROPRIETARY NOTE
 THIS DOCUMENT CONTAINS INFORMATION
 CONFIDENTIAL AND PROPRIETARY TO
 SAMTEC, INC. AND SHALL NOT BE REPRODUCED
 OR TRANSFERRED TO OTHER DOCUMENTS OR
 DISCLOSED TO OTHERS OR USED FOR ANY
 PURPOSE OTHER THAN THAT WHICH IT WAS
 OBTAINED WITHOUT THE EXPRESSED WRITTEN
 CONSENT OF SAMTEC, INC.

DO NOT SCALE DRAWING

SHEET SCALE: 0.75:1

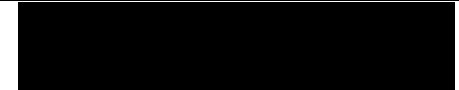

520 PARK EAST BLVD, NEW ALBANY, IN 47150
 PHONE: 812-944-6733 FAX: 812-948-5047
 e-Mail: info@SAMTEC.com code 55322

DESCRIPTION:
 SEALED CIRCULAR CABLE PLUG, ETHERNET

DWG. NO. **SCPE-X-XX.XX-XX-X-XX**

BY: CHAD F 12/11/2004 SHEET 2 OF 11

FIG. 3
 SCPE-G-XX.XX-BC SHOWN
 (SEE SHEET 9-11 FOR IN-PROCESS VIEWS)
 (SAME AS FIG. 1, UNLESS OTHERWISE STATED)

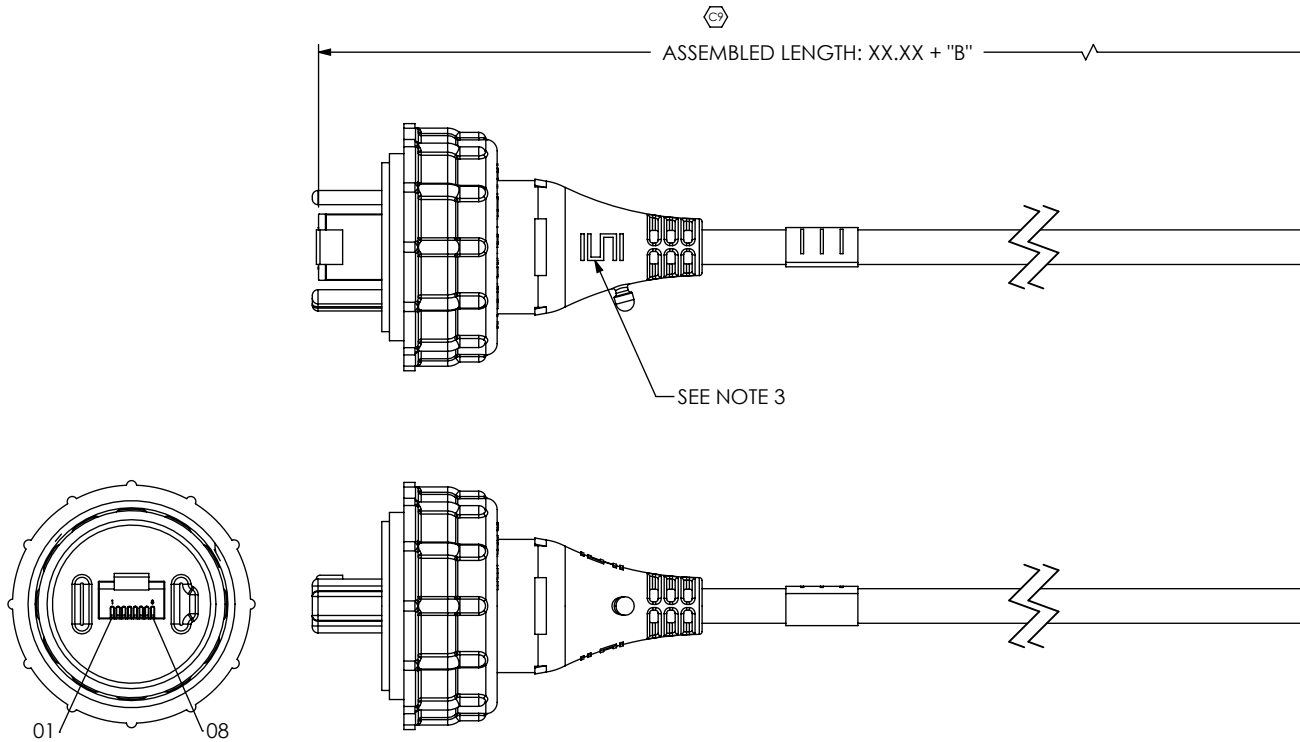
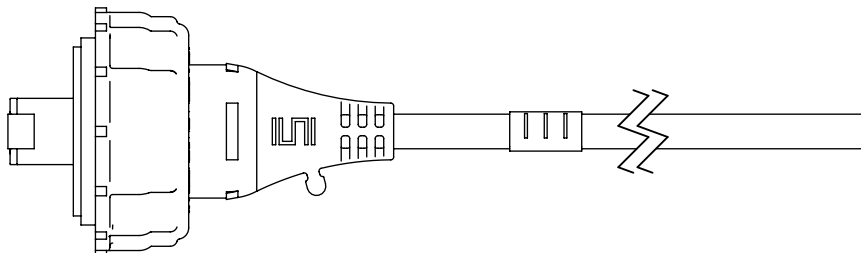

FIG 6.
 SCPE-G-XX.XX-BC-NP
 (SAME AS FIG. 3, UNLESS OTHERWISE STATED).



PROPRIETARY NOTE
 THIS DOCUMENT CONTAINS INFORMATION
 CONFIDENTIAL AND PROPRIETARY TO
 SAMTEC, INC. AND SHALL NOT BE REPRODUCED
 OR TRANSFERRED TO OTHER DOCUMENTS OR
 DISCLOSED TO OTHERS OR USED FOR ANY
 PURPOSE OTHER THAN THAT WHICH IT WAS
 OBTAINED WITHOUT THE EXPRESSED WRITTEN
 CONSENT OF SAMTEC, INC.

DO NOT SCALE DRAWING
 SHEET SCALE: 0.75:1

[Redacted]
 520 PARK EAST BLVD, NEW ALBANY, IN 47150
 PHONE: 812-944-6733 FAX: 812-948-5047
 e-Mail info@SAMTEC.com code 55322

DESCRIPTION:
 SEALED CIRCULAR CABLE PLUG, ETHERNET
 DWG. NO. **SCPE-X-XX.XX-XX-X-XX**

BY: CHAD F 12/11/2004 SHEET 3 OF 11

-D IN-PROCESS 1
(CUT CABLE TO LENGTH AND STRIP OUTER JACKET)

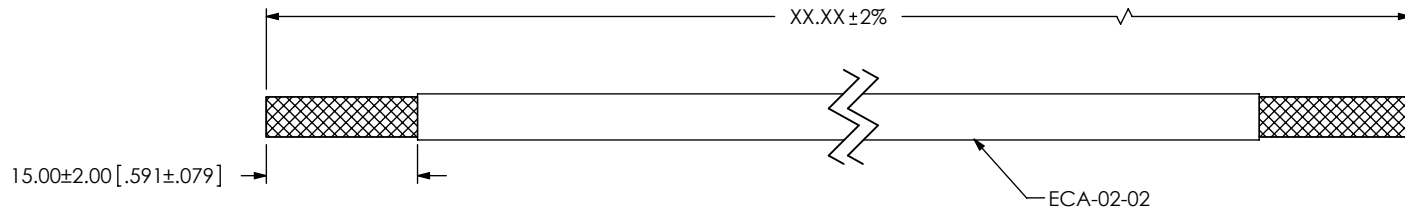

-D IN-PROCESS 2
(FOLD SHIELD BACK OVER JACKET)

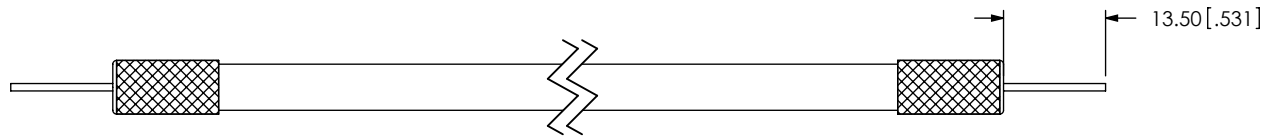

PROPRIETARY NOTE

THIS DOCUMENT CONTAINS INFORMATION CONFIDENTIAL AND PROPRIETARY TO SAMTEC, INC. AND SHALL NOT BE REPRODUCED OR TRANSFERRED TO OTHER DOCUMENTS OR DISCLOSED TO OTHERS OR USED FOR ANY PURPOSE OTHER THAN THAT WHICH IT WAS OBTAINED WITHOUT THE EXPRESSED WRITTEN CONSENT OF SAMTEC, INC.

DO NOT SCALE DRAWING

SHEET SCALE: 1:5



520 PARK EAST BLVD, NEW ALBANY, IN 47150
PHONE: 812-944-6733 FAX: 812-948-5047
e-Mail info@SAMTEC.com code 55322

DESCRIPTION:
SEALED CIRCULAR CABLE PLUG, ETHERNET

DWG. NO. SCPE-X-XX.XX-XX-X-XX

BY: CHAD F 12/11/2004 SHEET 4 OF 11

MODP-01-8P8C-X-XX

-D IN-PROCESS 3
TERMINATE FIRST END TO MODP-01-8P8C-X-XX

END 1

END 2

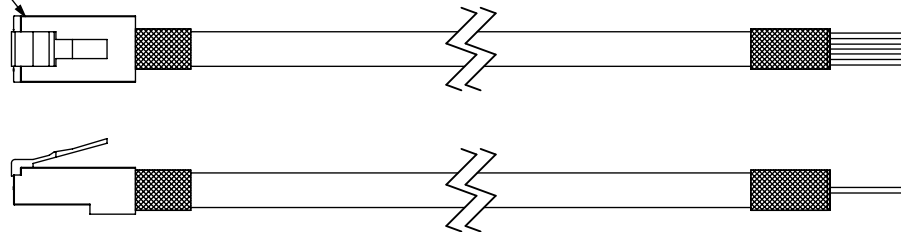
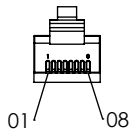

-D IN-PROCESS 4
TERMINATE SECOND END TO MODP-01-8P8C-X-XX
(SEE NOTE 8)

MODP-01-8P8C-X-XX

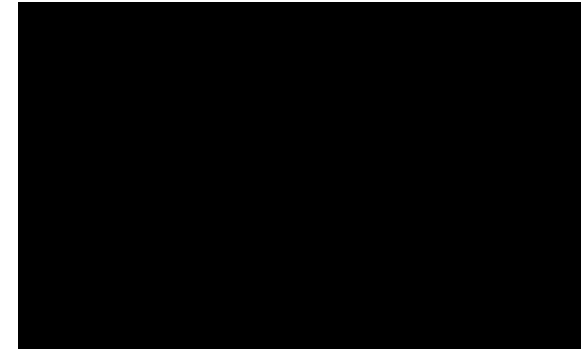
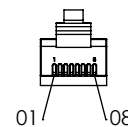
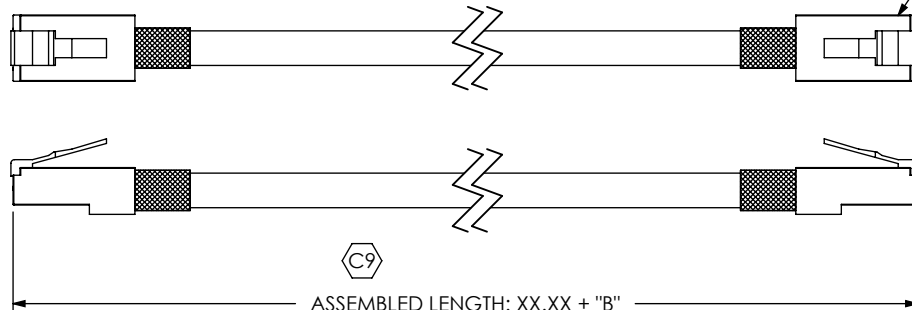
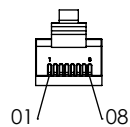

-D IN-PROCESS 5
REMOVE LATCH ARMS

BREAK LATCH ARM FREE (2 PLCS)



-D IN-PROCESS 6
ADD SCN-17-01

SCN-17-01 (2 PLCS)

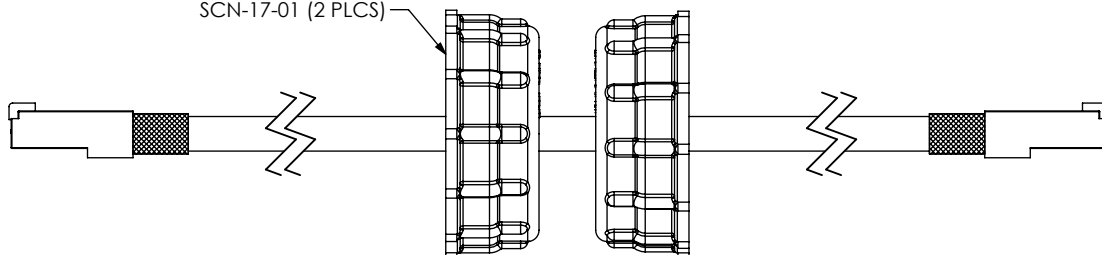

PROPRIETARY NOTE

THIS DOCUMENT CONTAINS INFORMATION CONFIDENTIAL AND PROPRIETARY TO SAMTEC, INC. AND SHALL NOT BE REPRODUCED OR TRANSFERRED TO OTHER DOCUMENTS OR DISCLOSED TO OTHERS OR USED FOR ANY PURPOSE OTHER THAN THAT WHICH IT WAS OBTAINED WITHOUT THE EXPRESSED WRITTEN CONSENT OF SAMTEC, INC.

DO NOT SCALE DRAWING

SHEET SCALE: 0.75:1

520 PARK EAST BLVD, NEW ALBANY, IN 47150
PHONE: 812-944-6733 FAX: 812-948-5047
e-Mail info@SAMTEC.com code 55322

DESCRIPTION:
SEALED CIRCULAR CABLE PLUG, ETHERNET

DWG. NO. **SCPE-X-XX.XX-XX-X-XX**

BY: CHAD F 12/11/2004 SHEET 5 OF 11

-D IN-PROCESS 7
PRE-MOLDING

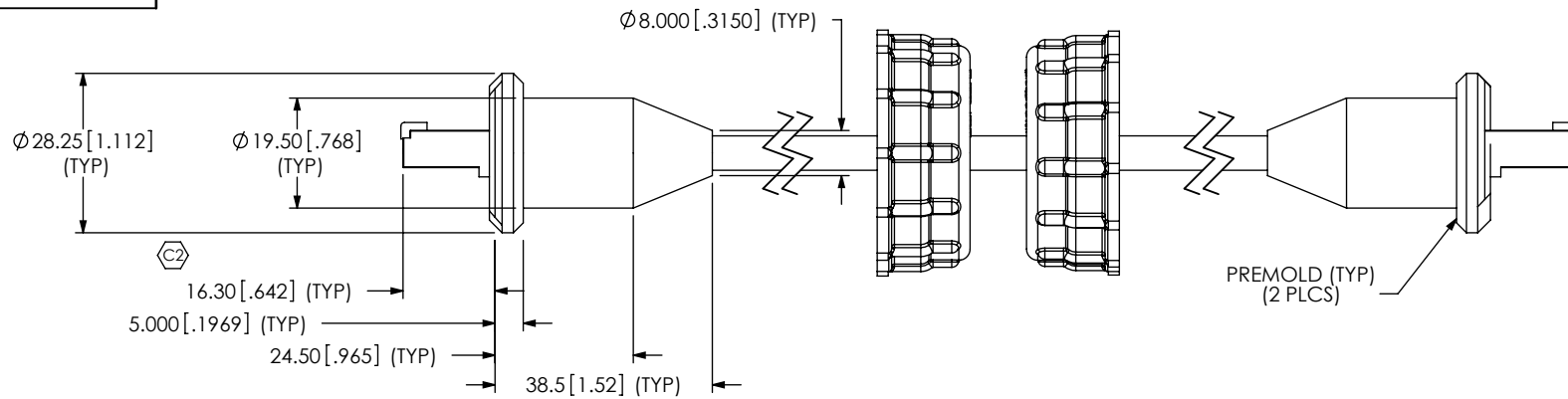

-D IN-PROCESS 8
OVERMOLDING

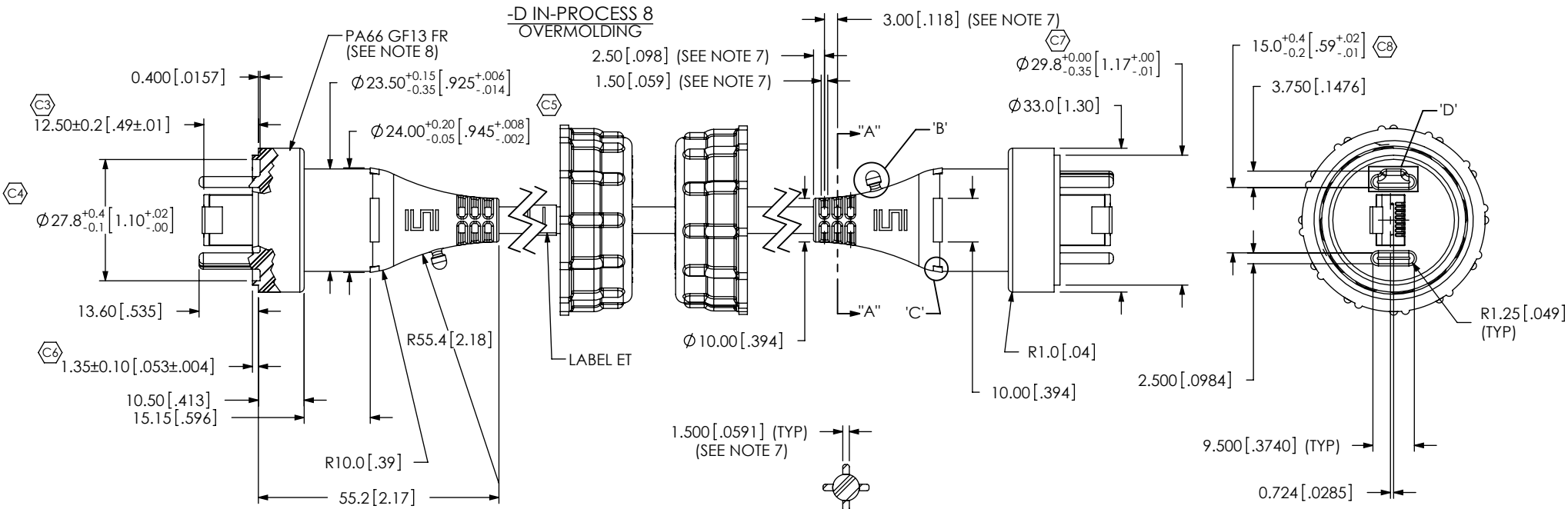

SECTION "A"- "A"

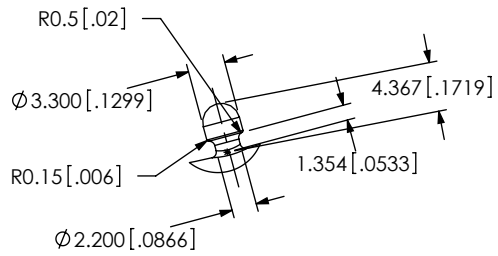

DETAIL 'B'
SCALE 1.5: 1

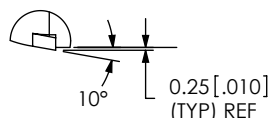

DETAIL 'C'
SCALE 1.5: 1

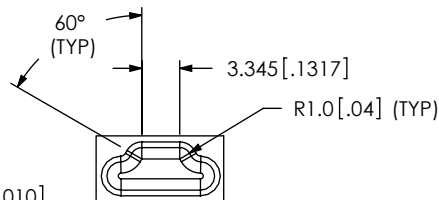

DETAIL 'D'
SCALE 1.5: 1

PROPRIETARY NOTE
THIS DOCUMENT CONTAINS INFORMATION CONFIDENTIAL AND PROPRIETARY TO SAMTEC, INC. AND SHALL NOT BE REPRODUCED OR TRANSFERRED TO OTHER DOCUMENTS OR DISCLOSED TO OTHERS OR USED FOR ANY PURPOSE OTHER THAN THAT WHICH IT WAS OBTAINED WITHOUT THE EXPRESSED WRITTEN CONSENT OF SAMTEC, INC.

DO NOT SCALE DRAWING

SHEET SCALE: 0.75:1

520 PARK EAST BLVD, NEW ALBANY, IN 47150
PHONE: 812-944-6733 FAX: 812-948-5047
e-Mail: info@SAMTEC.com code 55322

DESCRIPTION:
SEALED CIRCULAR CABLE PLUG, ETHERNET

DWG. NO.
SCPE-X-XX.XX-XX-X-XX

BY: CHAD F 12/11/2004 SHEET 6 OF 11

-S IN-PROCESS 1
(CUT CABLE TO LENGTH AND STRIP OUTER JACKET)

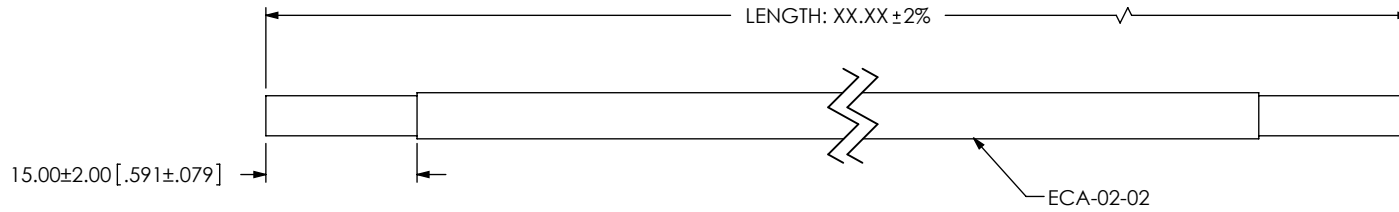

-S IN-PROCESS 2
(FOLD SHIELD BACK OVER JACKET AND ASSEMBLE BOOT)

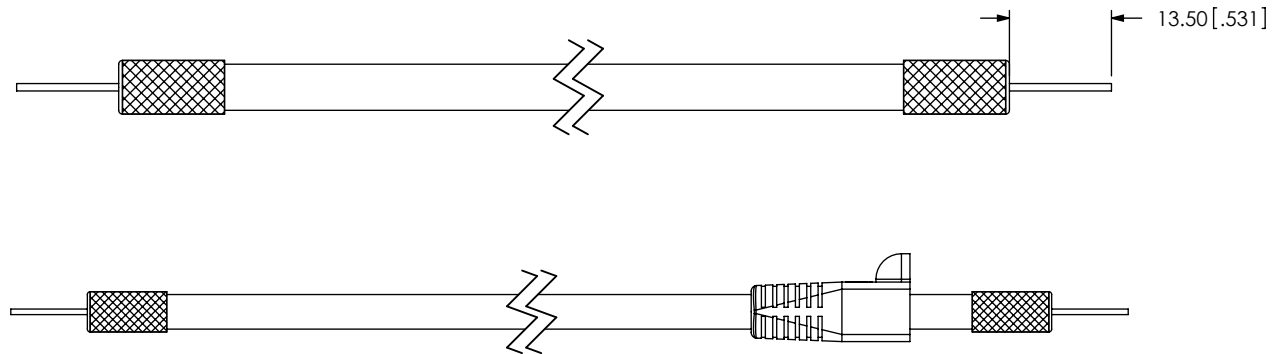

PROPRIETARY NOTE

THIS DOCUMENT CONTAINS INFORMATION CONFIDENTIAL AND PROPRIETARY TO SAMTEC, INC. AND SHALL NOT BE REPRODUCED OR TRANSFERRED TO OTHER DOCUMENTS OR DISCLOSED TO OTHERS OR USED FOR ANY PURPOSE OTHER THAN THAT WHICH IT WAS OBTAINED WITHOUT THE EXPRESSED WRITTEN CONSENT OF SAMTEC, INC.

DO NOT SCALE DRAWING

SHEET SCALE: 0.75:1



520 PARK EAST BLVD, NEW ALBANY, IN 47150
PHONE: 812-944-6733 FAX: 812-948-5047
e-Mail info@SAMTEC.com code 55322

DESCRIPTION:
SEALED CIRCULAR CABLE PLUG, ETHERNET

DWG. NO. SCPE-X-XX.XX-XX-X-XX

BY: CHAD F 12/11/2004 SHEET 7 OF 11

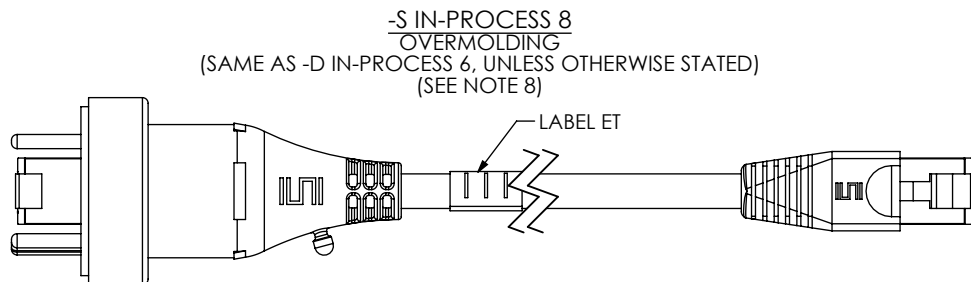
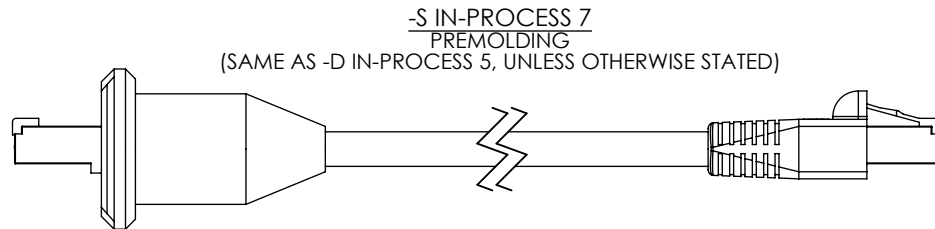
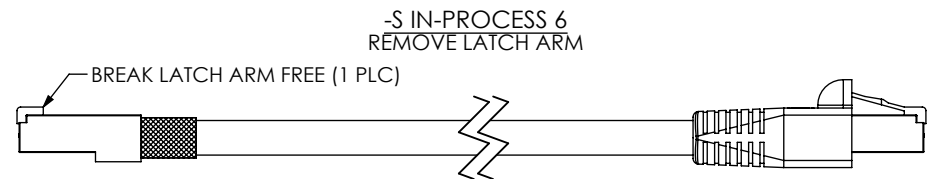
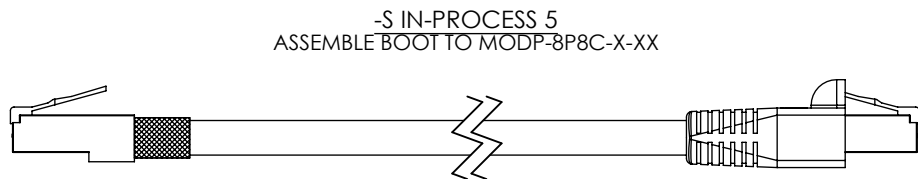
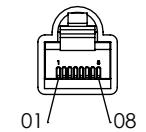
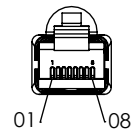
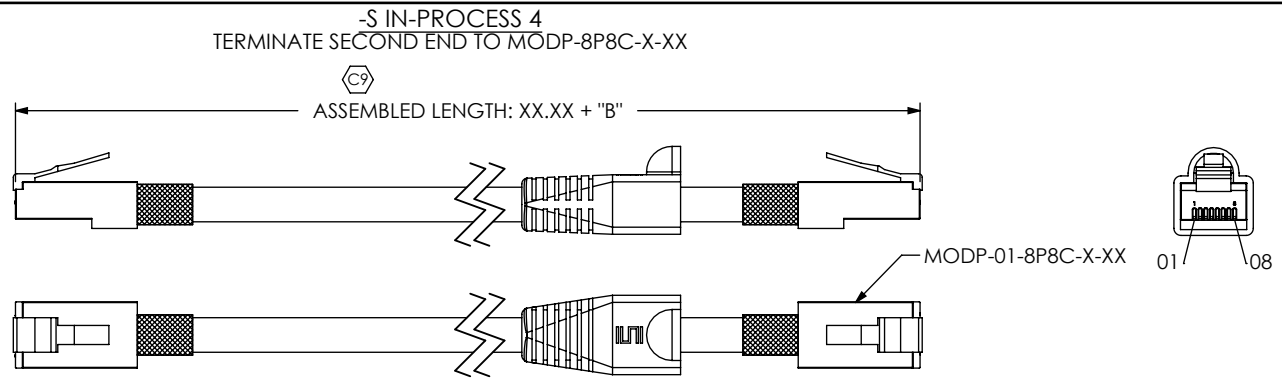
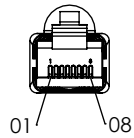
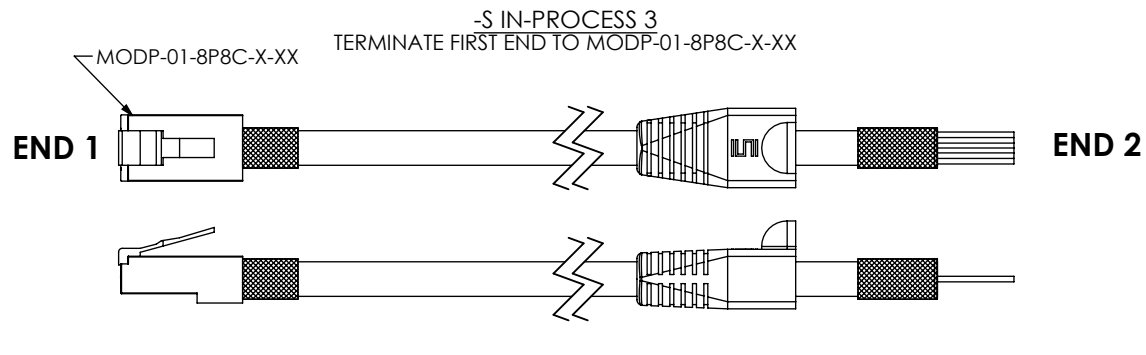

PROPRIETARY NOTE
THIS DOCUMENT CONTAINS INFORMATION CONFIDENTIAL AND PROPRIETARY TO SAMTEC, INC. AND SHALL NOT BE REPRODUCED OR TRANSFERRED TO OTHER DOCUMENTS OR DISCLOSED TO OTHERS OR USED FOR ANY PURPOSE OTHER THAN THAT WHICH IT WAS OBTAINED WITHOUT THE EXPRESSED WRITTEN CONSENT OF SAMTEC, INC.

DO NOT SCALE DRAWING
SHEET SCALE: 0.75:1

520 PARK EAST BLVD, NEW ALBANY, IN 47150
PHONE: 812-944-6733 FAX: 812-948-5047
e-Mail info@SAMTEC.com code 55322

DESCRIPTION:
SEALED CIRCULAR CABLE PLUG, ETHERNET
DWG. NO. **SCPE-X-XX.XX-XX-X-XX**

BY: CHAD F 12/11/2004 SHEET 8 OF 11

-BC IN-PROCESS 1
(CUT CABLE TO LENGTH AND STRIP OUTER JACKET)

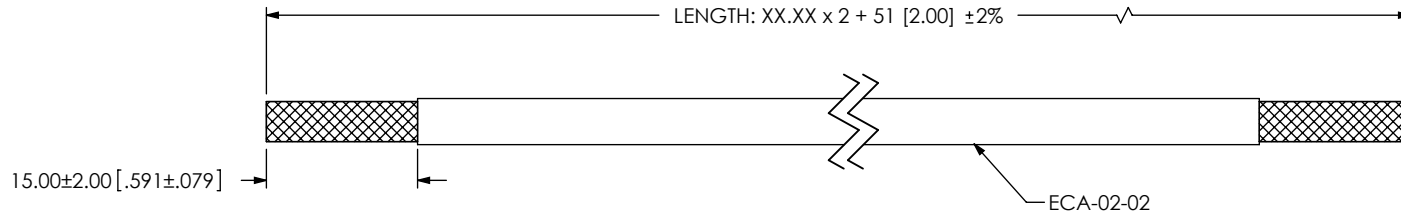

-BC IN-PROCESS 2
(FOLD SHIELD BACK OVER JACKET)

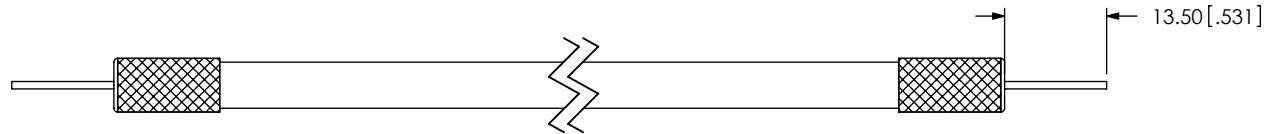

PROPRIETARY NOTE

THIS DOCUMENT CONTAINS INFORMATION CONFIDENTIAL AND PROPRIETARY TO SAMTEC, INC. AND SHALL NOT BE REPRODUCED OR TRANSFERRED TO OTHER DOCUMENTS OR DISCLOSED TO OTHERS OR USED FOR ANY PURPOSE OTHER THAN THAT WHICH IT WAS OBTAINED WITHOUT THE EXPRESSED WRITTEN CONSENT OF SAMTEC, INC.

DO NOT SCALE DRAWING

SHEET SCALE: 1:1.33333



520 PARK EAST BLVD, NEW ALBANY, IN 47150
PHONE: 812-944-6733 FAX: 812-948-5047
e-Mail info@SAMTEC.com code 55322

DESCRIPTION:
SEALED CIRCULAR CABLE PLUG, ETHERNET

DWG. NO. **SCPE-X-XX.XX-XX-X-XX**

BY: CHAD F 12/11/2004 SHEET 9 OF 11

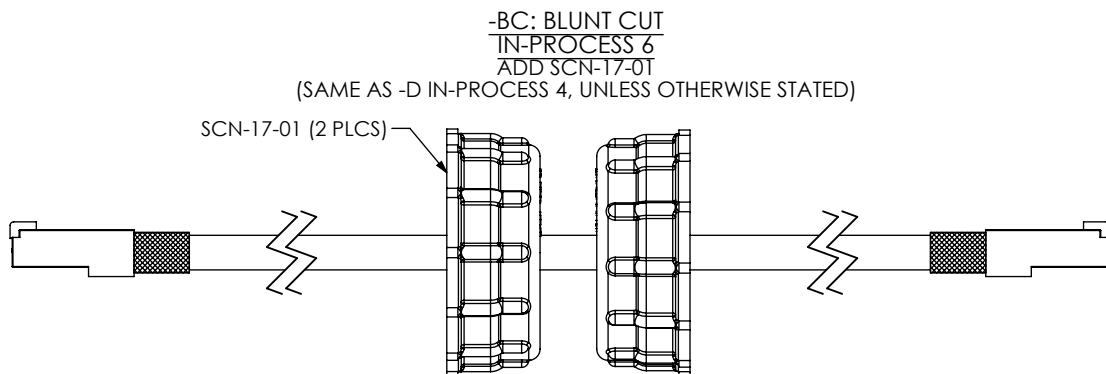
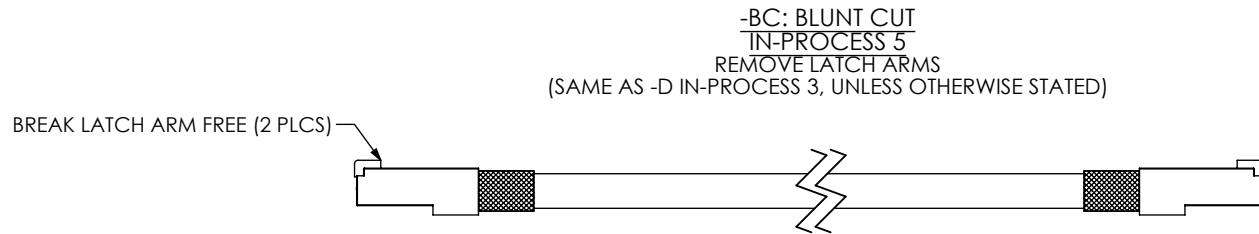
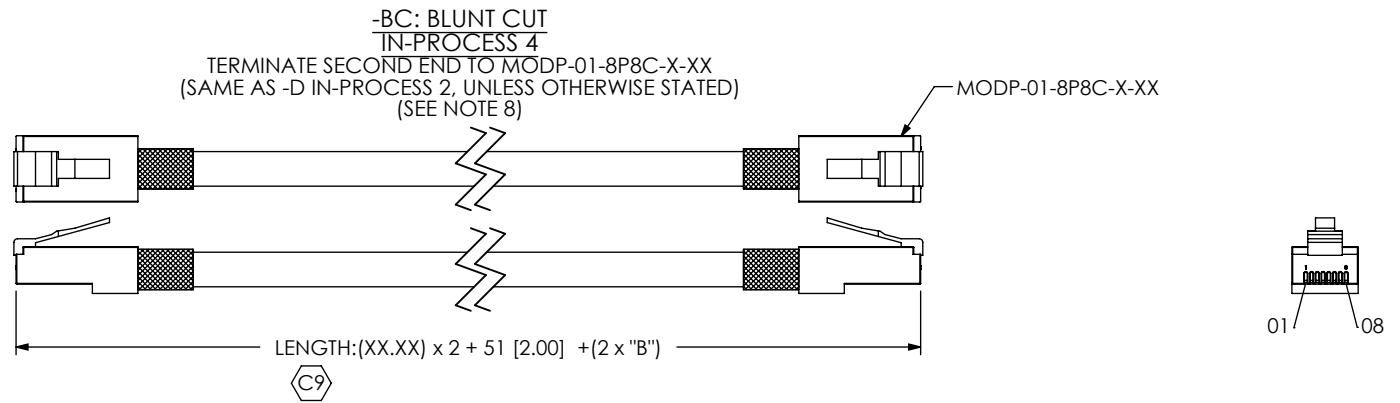
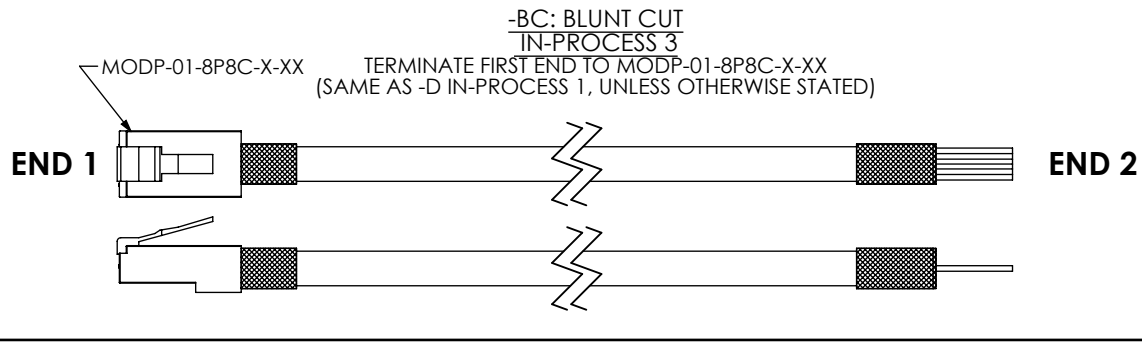

PROPRIETARY NOTE
THIS DOCUMENT CONTAINS INFORMATION CONFIDENTIAL AND PROPRIETARY TO SAMTEC, INC. AND SHALL NOT BE REPRODUCED OR TRANSFERRED TO OTHER DOCUMENTS OR DISCLOSED TO OTHERS OR USED FOR ANY PURPOSE OTHER THAN THAT WHICH IT WAS OBTAINED WITHOUT THE EXPRESSED WRITTEN CONSENT OF SAMTEC, INC.

DO NOT SCALE DRAWING
SHEET SCALE: 1:1.33333

[Redacted]

520 PARK EAST BLVD, NEW ALBANY, IN 47150
PHONE: 812-944-6733 FAX: 812-948-5047
e-Mail info@SAMTEC.com code 55322

DESCRIPTION:
SEALED CIRCULAR CABLE PLUG, ETHERNET
DWG. NO. **SCPE-X-XX.XX-XX-X-XX**

BY: CHAD F 12/11/2004 SHEET 10 OF 11

-BC: BLUNT CUT
IN-PROCESS 7
 PRE-MOLDING
 (SAME AS -D IN-PROCESS 5, UNLESS OTHERWISE STATED)

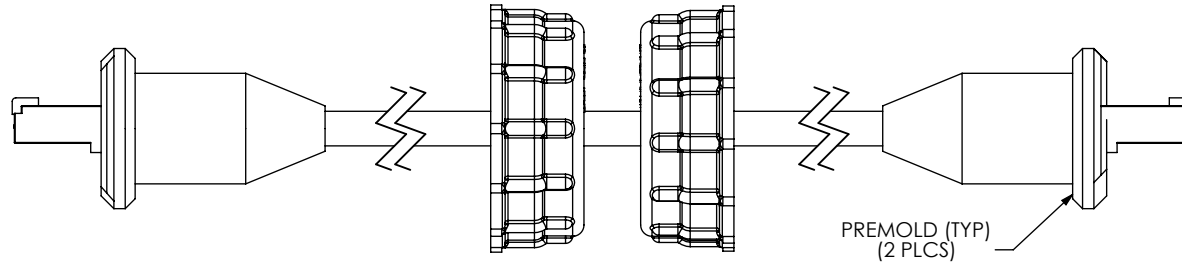

-BC: BLUNT CUT
IN-PROCESS 8
 OVERMOLDING
 (SAME AS -D IN-PROCESS 6, UNLESS OTHERWISE STATED)
 (SEE NOTE 8)

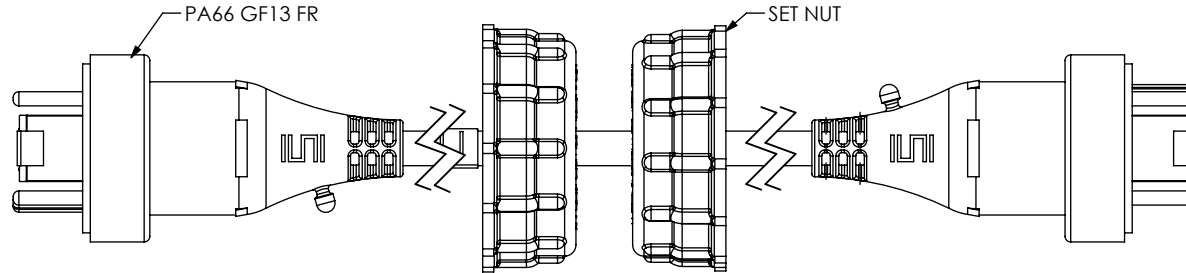

-BC: BLUNT CUT
IN-PROCESS 9
 (CUT CABLE IN HALF AND TRIM TO LENGTH)

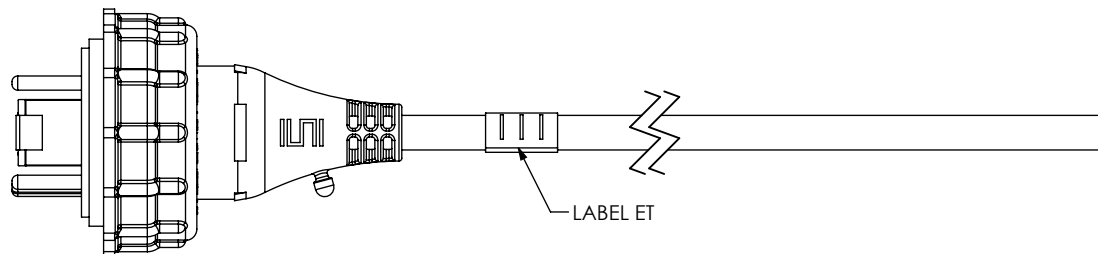

PROPRIETARY NOTE
 THIS DOCUMENT CONTAINS INFORMATION
 CONFIDENTIAL AND PROPRIETARY TO
 SAMTEC, INC. AND SHALL NOT BE REPRODUCED OR
 TRANSFERRED TO OTHER DOCUMENTS OR
 DISCLOSED TO OTHERS OR USED FOR ANY
 PURPOSE OTHER THAN THAT WHICH IT WAS
 OBTAINED WITHOUT THE EXPRESSED WRITTEN
 CONSENT OF SAMTEC, INC.

DO NOT SCALE DRAWING

SHEET SCALE: 1:1.33333

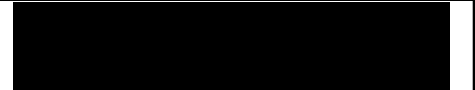

520 PARK EAST BLVD, NEW ALBANY, IN 47150
 PHONE: 812-944-6733 FAX: 812-948-5047
 e-Mail info@SAMTEC.com code 55322

DESCRIPTION:
SEALED CIRCULAR CABLE PLUG, ETHERNET

DWG. NO. **SCPE-X-XX.XX-XX-X-XX**

BY: CHAD F 12/11/2004 SHEET 11 OF 11