**18-Bit Universal Bus Transceiver
with 3-State Outputs**
Product Features

- Designed for low voltage operation, $V_{CC} = 2.3V$ to $3.6V$
- Hysteresis on all inputs
- Typical V_{OLP} (Output Ground Bounce)
< $0.8V$ at $V_{CC} = 3.3V, T_A = 25^\circ C$
- Typical V_{OHV} (Output V_{OH} Undershoot)
< $2.0V$ at $V_{CC} = 3.3V, T_A = 25^\circ C$
- Bus Hold retains last active bus state during 3-STATE, eliminating the need for external pullup resistors
- Industrial operation at $-40^\circ C$ to $+85^\circ C$
- Packages available:
– 56-pin 240 mil wide plastic TSSOP (A)

Product Description

The PI74ALVCH162601 uses D-type latches and D-type flip-flops with 3-state outputs to allow data flow in transparent, latched, and clocked modes.

Data flow in each direction is controlled by Output Enable (\overline{OEAB} and \overline{OEBA}), Latched Enable (LEAB and LEBA), and Clock (CLKAB and CLKBA) inputs. The clock can be controlled by the Clock Enable ($\overline{CLKENAB}$ and $\overline{CLKENBA}$) inputs. For A-to-B data flow, the device operates in the transparent mode when LEAB is HIGH. When LEAB is LOW, the A data is latched if CLKAB is held at a high or low logic level. If LEAB is low, the A-bus is stored in the latch/flip-flop on the low-to-high transition of CLKAB. When \overline{OEAB} is low, the outputs are active. When \overline{OEAB} is HIGH, the outputs are in the high-impedance state.

Data flow for B to A is similar to that of A to B but uses \overline{OEBA} , LEBA, CLKBA, and $\overline{CLKENBA}$.

To reduce overshoot and undershoot, the B-port outputs include 26Ω series resistors.

To ensure the high-impedance state during power up or power down, OE should be tied to V_{CC} through a pull-up resistor; the minimum value of the resistor is determined by the current-sinking capability of the driver.

The PI74ALVCH162601 has “Bus Hold” which retains the data input’s last state whenever the data input goes to high-impedance preventing “floating” inputs and eliminating the need for pullup/down resistors.

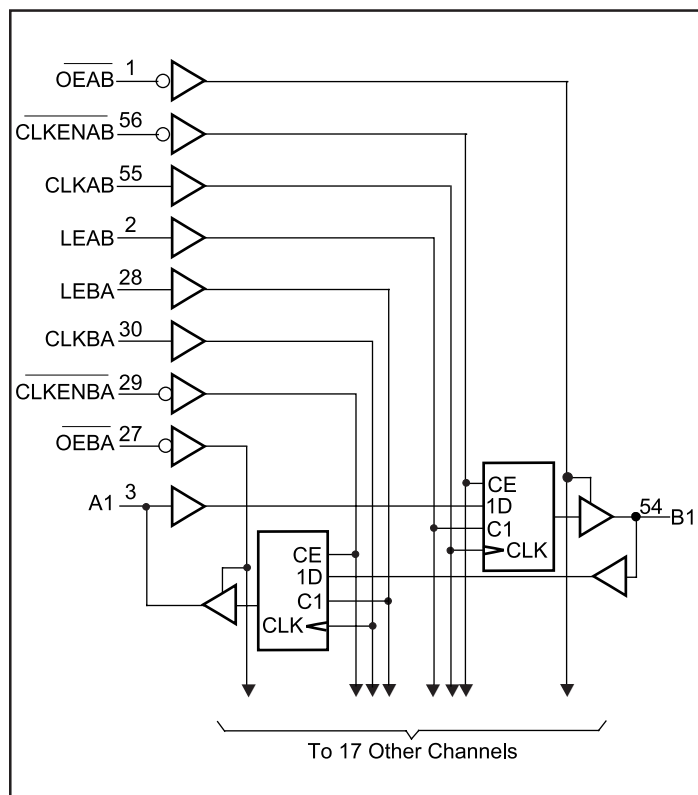
Logic Block Diagram

Product Pin Description

| Pin Name | Description |
|---------------------------|----------------------------------|
| $\overline{\text{CLKEN}}$ | Clock Enable Input (Active LOW) |
| $\overline{\text{OE}}$ | Output Enable Input (Active LOW) |
| LE | Latch Enable (Active HIGH) |
| CLK | Clock Input (Active HIGH) |
| Ax | Data I/O |
| Bx | Data I/O |
| GND | Ground |
| Vcc | Power |

Truth Table^(1,2)

| Inputs | | | | | Output B |
|---------|------|------|-------|---|-------------------------------|
| CLKENAB | OEAB | LEAB | CLKAB | A | |
| X | H | X | X | X | Z |
| X | L | H | X | L | L |
| X | L | H | X | H | H |
| H | L | L | X | X | B ₀ ⁽³⁾ |
| H | L | L | X | X | B ₀ ⁽³⁾ |
| L | L | L | ↑ | L | L |
| L | L | L | ↑ | H | H |
| L | L | L | L | X | B ₀ ⁽³⁾ |
| L | L | L | H | X | B ₀ ⁽⁴⁾ |

Product Pin Configuration

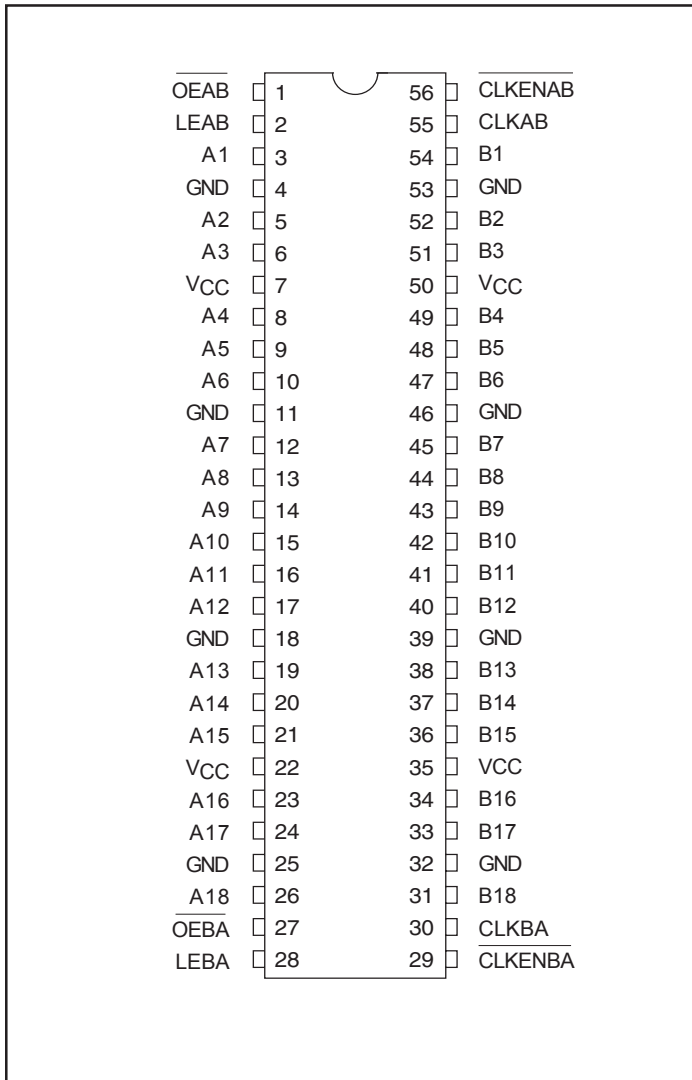

Notes:

1. H = High Signal Level
L = Low Signal Level
Z = High Impedance
↑ = LOW-to-HIGH Transition
2. A-to-B data flow is shown: B-to-A flow is similar but uses OEBA, LEBA, CLKBA, and CLKENBA.
3. Output level before the indicated steady-state input conditions were established.
4. Output level before the indicated steady-state input conditions were established, provided that CLKAB is LOW before LEAB goes LOW.

Maximum Ratings

(Above which the useful life may be impaired. For user guidelines, not tested.)

| | |
|---|--------------------------------|
| Storage Temperature | -65°C to +150°C |
| Supply Voltage Range, V _{CC} | -0.5V to 4.6V |
| Input Voltage Range, V _I : | |
| Except I/O ports (See Note 1): | -0.5V to 4.6V |
| I/O ports (See Notes 1 and 2) | -0.5V to V _{CC} +0.5V |
| Output Voltage Range, V _O (See Notes 1 and 2) | -0.5V to V _{CC} +0.5V |
| Input Clamp current, I _{IK} (V _I < 0) | -50mA |
| Output Clamp current, I _{OK} (V _O < 0 or V _O > V _{CC}) | ±50mA |
| Continuous Output Current, I _O (V _O = 0 to V _{CC}) | ±50mA |
| Continuous Current through each V _{CC} or GND | ±100mA |
| Maximum Power Dissipation: | |
| A package | 1W |
| V package | 1.4W |

Note:

Stresses greater than those listed under MAXIMUM RATINGS may cause permanent damage to the device. This is a stress rating only and functional operation of the device at these or any other conditions above those indicated in the operational sections of this specification is not implied. Exposure to absolute maximum rating conditions for extended periods may affect reliability.

Notes:

1. The input and output negative-voltage ratings may be exceeded if the input and output clamp-current ratings are observed.
2. This value is limited to 4.6V maximum.

Recommended Operating Conditions⁽¹⁾

| Parameters | Description | Test Conditions | Min. | Typ. | Max. | Units |
|------------------|------------------------------------|--------------------------------|------|------|-----------------|-------|
| V _{CC} | Supply Voltage | | 2.3 | | 3.6 | V |
| V _{IH} | Input HIGH Voltage | V _{CC} = 2.3V to 2.7V | 1.7 | | | |
| | | V _{CC} = 2.7V to 3.6V | 2.0 | | | |
| V _{IL} | Input LOW Voltage | V _{CC} = 2.3V to 2.7V | | | 0.7 | |
| | | V _{CC} = 2.7V to 3.6V | | | 0.8 | |
| V _{IN} | Input Voltage | | 0 | | V _{CC} | |
| V _{OUT} | Output Voltage | | 0 | | V _{CC} | |
| I _{OH} | High-level Output Current (A Port) | V _{CC} = 2.3V | | | -12 | mA |
| | | V _{CC} = 2.7V | | | -12 | |
| | | V _{CC} = 3.0V | | | -24 | |
| I _{OL} | Low-level Output Current (A Port) | V _{CC} = 2.3V | | | 12 | |
| | | V _{CC} = 2.7V | | | 12 | |
| | | V _{CC} = 3.0V | | | 24 | |
| I _{OH} | High-level Output Current (B Port) | V _{CC} = 2.3V | | | -6 | |
| | | V _{CC} = 2.7V | | | -8 | |
| | | V _{CC} = 3.0V | | | -12 | |
| I _{OL} | Low-level Output Current (B Port) | V _{CC} = 2.3V | | | 6 | |
| | | V _{CC} = 2.7V | | | 8 | |
| | | V _{CC} = 3.0V | | | 12 | |
| T _A | Operating Free-Air Temperature | | -40 | | 85 | °C |

Notes:

1. Unused control inputs must be held HIGH or LOW to prevent them from floating.

DC Electrical Characteristics (Over the Operating Range, $T_A = -40^\circ\text{C}$ to $+85^\circ\text{C}$, $V_{CC} = 3.3\text{V} \pm 10\%$)

| Parameters | Test Conditions | $V_{CC}^{(1)}$ | Min. | Typ. ⁽²⁾ | Max. | Units |
|-----------------------------|---|------------------------|----------------|---------------------|-----------|-------|
| V_{OH} (B Port) | $I_{OH} = -100 \mu\text{A}$ | Min. to Max. | $V_{CC} - 0.2$ | | | |
| | $I_{OH} = -4 \text{ mA}$ | $V_{IH} = 1.7\text{V}$ | 2.3V | 1.9 | | |
| | $I_{OH} = -6 \text{ mA}$ | $V_{IH} = 1.7\text{V}$ | 2.3V | 1.7 | | |
| | | $V_{IH} = 2.0\text{V}$ | 3.0V | 2.4 | | |
| | $I_{OH} = -8 \text{ mA}$ | $V_{IH} = 2.0\text{V}$ | 2.7V | 2.0 | | |
| $I_{OH} = -12 \text{ mA}$ | $V_{IH} = 2.0\text{V}$ | 3.0V | 2.0 | | | |
| V_{OH} (A Port) | $I_{OH} = -100 \mu\text{A}$ | Min. to Max. | $V_{CC} - 0.2$ | | | |
| | $I_{OH} = -6 \text{ mA}$ | $V_{IH} = 1.7\text{V}$ | 2.3V | 2.0 | | |
| | $I_{OH} = -12 \text{ mA}$ | $V_{IH} = 1.7\text{V}$ | 2.3V | 1.7 | | |
| | | $V_{IH} = 2.0\text{V}$ | 2.7V | 2.2 | | |
| | $I_{OH} = -24 \text{ mA}$ | $V_{IH} = 2.0\text{V}$ | 3.0V | 2.4 | | |
| V_{OL} (B Port) | $I_{OL} = 100 \mu\text{A}$ | Min. to Max. | | | 0.2 | |
| | $I_{OL} = 4 \text{ mA}$ | $V_{IL} = 0.7\text{V}$ | 2.3V | | 0.4 | |
| | $I_{OL} = 6 \text{ mA}$ | $V_{IL} = 0.7\text{V}$ | 2.3V | | 0.55 | |
| | | $V_{IL} = 0.8\text{V}$ | 3.0V | | 0.55 | |
| | $I_{OL} = 8 \text{ mA}$ | $V_{IL} = 0.8\text{V}$ | 2.7V | | 0.6 | |
| $I_{OL} = 12 \text{ mA}$ | $V_{IL} = 0.8\text{V}$ | 3.0V | | 0.8 | | |
| V_{OL} (A Port) | $I_{OL} = 100 \mu\text{A}$ | Min. to Max. | | | 0.2 | |
| | $I_{OL} = 6 \text{ mA}$ | $V_{IL} = 0.7\text{V}$ | 2.3V | | 0.4 | |
| | $I_{OL} = 12 \text{ mA}$ | $V_{IL} = 0.7\text{V}$ | 2.3V | | 0.7 | |
| | | $V_{IL} = 0.8\text{V}$ | 2.7V | | 0.4 | |
| | $I_{OL} = 24 \text{ mA}$ | $V_{IL} = 0.8\text{V}$ | 3.0V | | 0.55 | |
| I_I | $V_I = V_{CC}$ or GND | 3.6V | | | ± 5 | |
| I_I (Hold) ⁽³⁾ | $V_I = 0.7\text{V}$ | 2.3V | 45 | | | |
| | $V_I = 1.7\text{V}$ | | -45 | | | |
| | $V_I = 0.8\text{V}$ | 3.0V | 75 | | | |
| | $V_I = 2.0\text{V}$ | | -75 | | | |
| | $V_I = 0$ to 3.6V | 3.6V | | | ± 500 | |
| $I_{OZ}^{(4)}$ | $V_O = V_{CC}$ or GND | 3.6V | | | ± 10 | |
| I_{CC} | $V_I = V_{CC}$ or GND | $I_O = 0$ | 3.6V | | 40 | |
| ΔI_{CC} | One input at $V_{CC} - 0.6\text{V}$, Other inputs at V_{CC} or GND | 3V to 3.6V | | | 750 | |
| C_I Control Inputs | $V_I = V_{CC}$ or GND | 3.3V | | 4 | | pF |
| C_{IO} A or B ports | $V_O = V_{CC}$ or GND | 3.3V | | 8 | | |

Notes:

1. For Max. or Min. conditions, use appropriate value specified under Electrical Characteristics for the applicable device type.
2. Typical values are at $V_{CC} = 3.3\text{V}$, $+25^\circ\text{C}$ ambient and maximum loading.
3. Bus Hold maximum dynamic current required to switch the input from one state to another.
4. For I/O ports, the I_{OZ} includes the input leakage current.

Timing Requirements over Operating Range⁽¹⁾

| Parameters | Description | V _{CC} = 2.5V ± 0.2V | | V _{CC} = 2.7V | | V _{CC} = 3.3V ± 0.3V | | Units |
|-------------------------------|-------------------------------|-------------------------------|------|------------------------|------|-------------------------------|------|-------|
| | | Min. | Max. | Min. | Max. | Min. | Max. | |
| f _{CLOCK} | Clock frequency | 0 | 140 | 0 | 150 | 0 | 150 | MHz |
| t _w Pulse Duration | LE high | 3.3 | | 3.3 | | 3.3 | | ns |
| | CLK high or low | 3.3 | | 3.3 | | 3.3 | | |
| t _{SU} Setup time | Data before CLK high | 2.3 | | 2.4 | | 2.1 | | |
| | Data before LE low, CLK high | 2.0 | | 1.6 | | 1.6 | | |
| | Data before LE low, CLK low | 1.3 | | 1.2 | | 1.1 | | |
| | CLKEN before CLK high | 2.0 | | 2.0 | | 1.7 | | |
| t _H Hold time | Data after CLK high | 0.7 | | 0.7 | | 0.8 | | |
| | Data after LE low, CLK high | 1.3 | | 1.6 | | 1.4 | | |
| | Data after LE low, CLK low | 1.7 | | 2.0 | | 1.7 | | |
| | CLKEN after CLK high | 0.3 | | 0.5 | | 0.6 | | |
| Δt/Δv | Input Transition Rise or Fall | 0 | 10 | 0 | 10 | 0 | 10 | ns/V |

Notes:

1. Unused control inputs must be held HIGH or LOW to prevent them from floating.

Switching Characteristics over Operating Range

| Parameters | From(INPUT) | To(OUTPUT) | V _{CC} = 2.5V ± 0.2V | | V _{CC} = 2.7V | | V _{CC} = 3.3 V ± 0.3V | | Units |
|------------------|--------------------------|------------|-------------------------------|------|------------------------|------|--------------------------------|------|-------|
| | | | Min. ⁽¹⁾ | Max. | Min. ⁽¹⁾ | Max. | Min. ⁽¹⁾ | Max. | |
| f _{MAX} | | | 140 | | 150 | | 150 | | MHz |
| t _{PD} | A | B | 1.8 | 5.4 | | 5.2 | 1.6 | 4.5 | ns |
| t _{PD} | B | A | 1.3 | 4.9 | | 4.6 | 1 | 4.1 | |
| t _{PD} | LEAB | B | 1.5 | 6.1 | | 5.9 | 1.5 | 5.1 | |
| t _{PD} | LEBA | A | 1.4 | 5.6 | | 5.3 | 1 | 4.7 | |
| t _{PD} | CLKAB | B | 2 | 6.7 | | 6.3 | 1.6 | 5.5 | |
| t _{PD} | CLKBA | A | 1.8 | 6.2 | | 5.8 | 1.4 | 5 | |
| t _{EN} | $\overline{\text{OEAB}}$ | B | 1.7 | 6.6 | | 6.7 | 1.6 | 5.7 | |
| t _{DIS} | $\overline{\text{OEAB}}$ | B | 2.5 | 5.9 | | 5.3 | 1.8 | 4.8 | |
| t _{EN} | $\overline{\text{OEBA}}$ | A | 1.2 | 6 | | 6.1 | 1.1 | 5.2 | |
| t _{DIS} | $\overline{\text{OEBA}}$ | A | 2.1 | 5.4 | | 4.8 | 1.6 | 4.4 | |

Notes:

1. Minimum limits are guaranteed but not tested on Propagation Delays.

Operating Characteristics, T_A = 25°C

| Parameter | | Test Conditions | V _{CC} = 2.5V ± 0.2V | V _{CC} = 3.3V ± 0.3V | Units |
|---|------------------|--------------------------------------|-------------------------------|-------------------------------|-------|
| | | | Typical | | |
| C _{PD} Power Dissipation Capacitance | Outputs Enabled | C _L = 50pF, f = 10 MHz | 41 | 50 | pF |
| | Outputs Disabled | | 6 | 6 | |

Packaging Mechanical

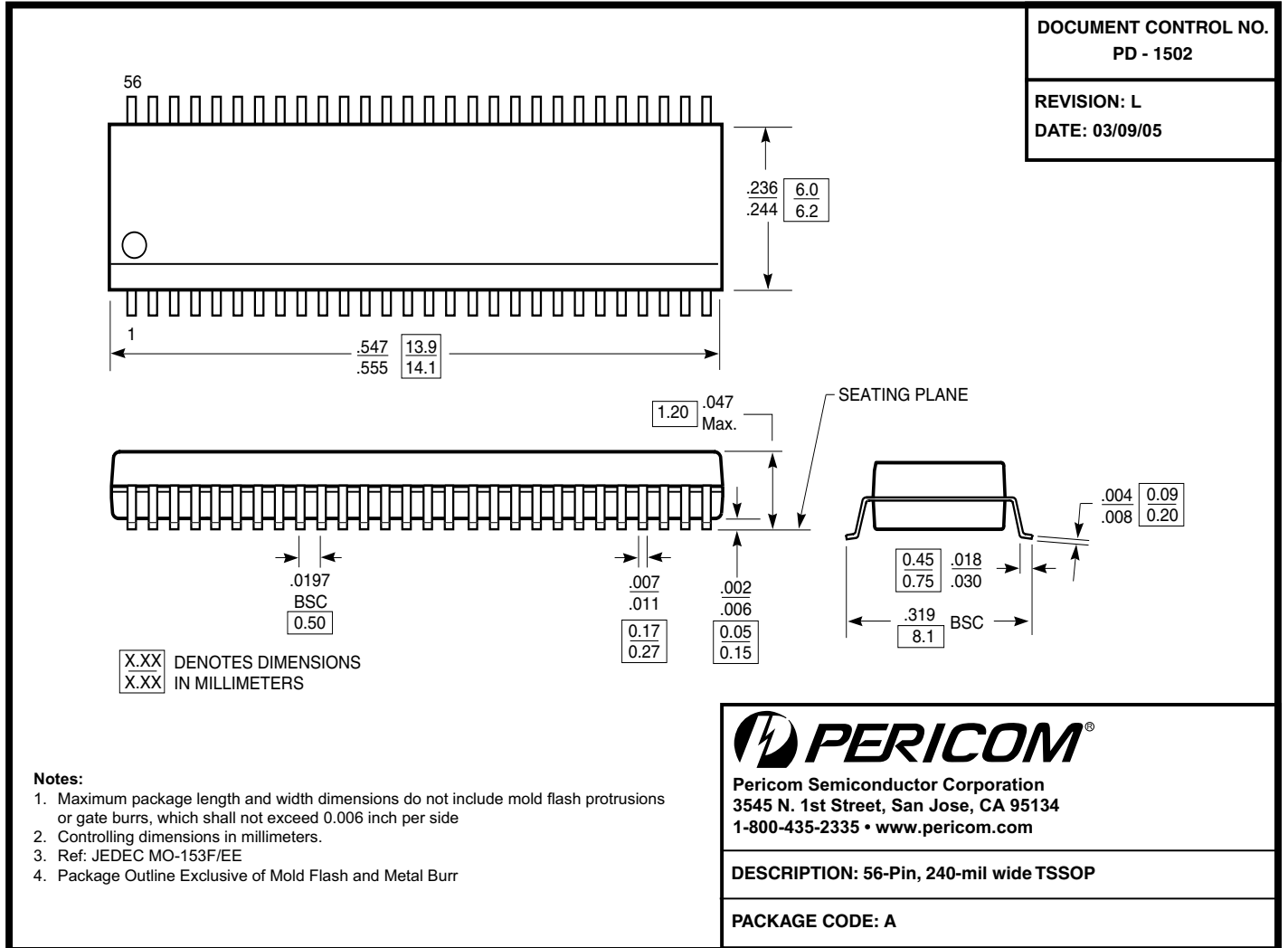

Ordering Information

| Ordering Code | Package Code | Package Type |
|------------------|--------------|---------------------------------------|
| PI74ALVCH162601A | A | 56-pin 240 mil wide plastic TSSOP (A) |

Notes:

- Thermal characteristics can be found on the company web site at www.pericom.com/packaging/
- Adding an X suffix = Tape/Reel