

1. MATERIAL: ALNICO 5, SINTERED, ANISOTROPIC
2. FINISH: UNFINISHED OR GROUND
3. MAGNETIZATION LEVEL: SATURATED
4. MAGNETIZATION DIRECTION: PARALLEL TO LENGTH
5. MAGNETIC FLUX DENSITY: 120 GAUSS (12 mT) MINIMUM, 240 GAUSS (24 mT) MAXIMUM
. AT THE MEASUREMENT LOCATION SPECIFIED BELOW (TOOL TN 3927-C MAY BE USED)
6. DIMENSIONS ARE AS SPECIFIED IN INCHES.
7. UNSPECIFIED CRITERIA ARE PER LATEST REVISION OF IMA MMPA STANDARD 0100.
8. PACKING: 100 MAGNETS ARE SHRINK-WRAPPED TO A PIECE OF FLAT CARDBOARD WITH
. ADJACENT POLES ATTRACTING AS SHOWN BELOW. MULTIPLE CARDBOARD FLATS ARE
. PACKED INTO BOXES. CARDBOARD OR OTHER SPACERS ARE USED TO PROVIDE A
. MINIMUM MAGNET-TO-MAGNET SEPARATION OF 0.25 INCH (6 mm) BETWEEN LAYERS.
. MAXIMUM BOX WEIGHT IS 25 POUNDS. OTHER PACKING METHODS REQUIRE WRITTEN
. APPROVAL.

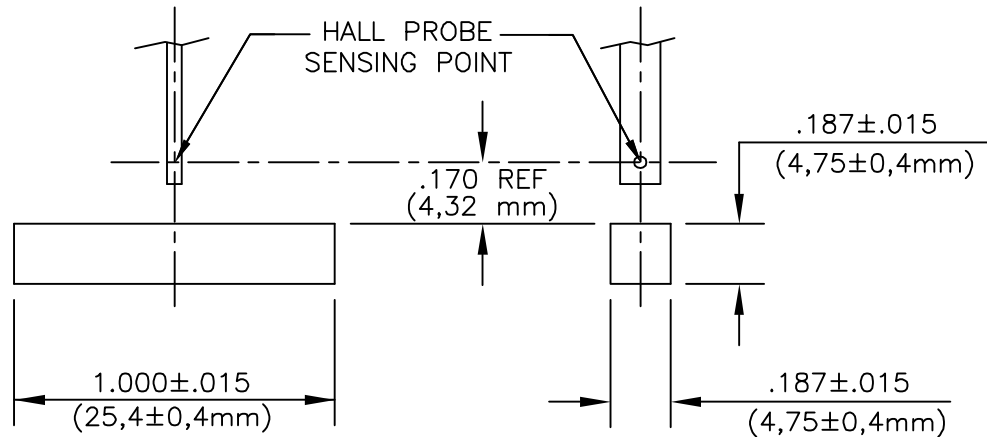

PACKING

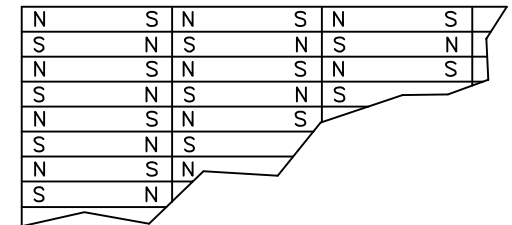

ORIGINAL DCR NO.



PROPRIETARY NOTE: THE INFORMATION ON THIS DRAWING IS THE CONFIDENTIAL PROPERTY OF HAMLIN. THIS DRAWING MUST NOT BE MADE PUBLIC OR COPIED UNLESS AUTHORIZED IN WRITING BY HAMLIN. THIS DRAWING IS SUBJECT TO RETURN UPON DEMAND.

SHEET
1 of 1

DCR NO.
B0232

REV.
AD

DRAWN BY:
FH

DATE:
1/12/64

DESCRIPTION OF REVISION:
IMPROVE MAGNETIZATION LEVEL SPECIFICATION
REVISE OTHER NOTES FOR CONSISTENCY & IMPROVEMENT
REVISE FORMAT

DRAWN BY:
MCP

DATE:
9/19/03

APP'D BY:

DATE:

APP'D BY:
MCP

DATE:
9/26/03