

LOC	DIST	REV	DATE	BY	APPD
GP	00	B	12APR07	LZ	SY
		B2	27JUN2011	D.P	C.W

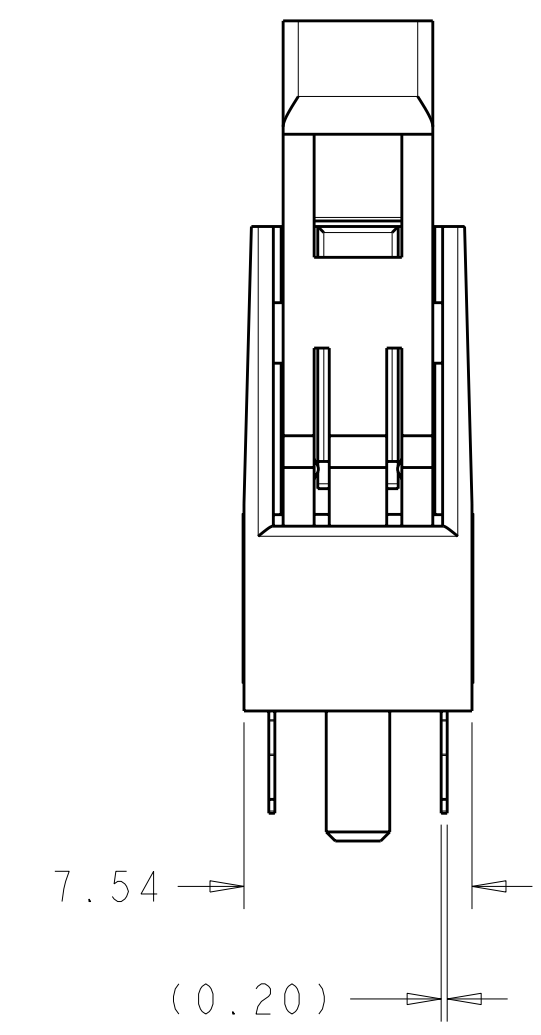

- MATERIALS:**
- HOUSING: HIGH TEMPERATURE, UL94 V-0
 - EXTRACTOR: HIGH TEMPERATURE THERMOPLASTIC,
 - CONTACTS: COPPER ALLOY
 - SUPPORT PLATE: LCP, UL94 V-0
- INTERFACE FINISH:** 0.00076 MIN THK GOLD OVER 0.00127 MIN THICK NICKEL.
- FINISHED HOLE SIZE:** 0.15 MAXIMUM ANNULAR RING.
 COPPER PLATING: 0.025-0.050
 TIN-LEAD PLATING: 0.0038-0.0124
 FOR PTH TIN-LEAD PLATING ONLY, FINISHED HOLE TOLERANCE MAY BE +.05/- .058 IN ZONE 1, AND ±0.076 IN ZONE 11
- KEEP OUT ZONE.**
- KEEP OUT AREA RESERVED FOR SOCKET EXTRACTORS, BOTH ENDS.**
- LED LOCATION AS APPLICABLE PER CUSTOMER.**
7. APPROXIMATE SEATING FORCE WILL BE 3781-5338N [850-1200 lb] FOR THE 240 POSITION SOCKET ASSEMBLY.
8. HOLE INDICATED IS PART OF THE STANDARD 240 POSITION FOOTPRINT. REQUIRED FOR THE SOLDERTAIL VERSION. MAY BE OMITTED FOR THE PRESS FIT VERSIONS.
9. HOLE INDICATED IS PART OF THE STANDARD 240 POSITION FOOTPRINT. REQUIRED FOR SOLDERTAIL AND -2 PRESS FIT VERSIONS. MAY BE OMITTED FOR -1 & -3 PRESS FIT VERSIONS.
10. COMPLIANT PIN FINISH: 0.00254 MIN THICK MATTE TIN OVER 0.00127 MIN THICK NICKEL.
11. COMPLIANT PIN FINISH: 0.00254 MIN THICK BRIGHT TIN LEAD OVER 0.00127 MIN THICK NICKEL.
12. COMPLIES WITH JEDEC SO-003.

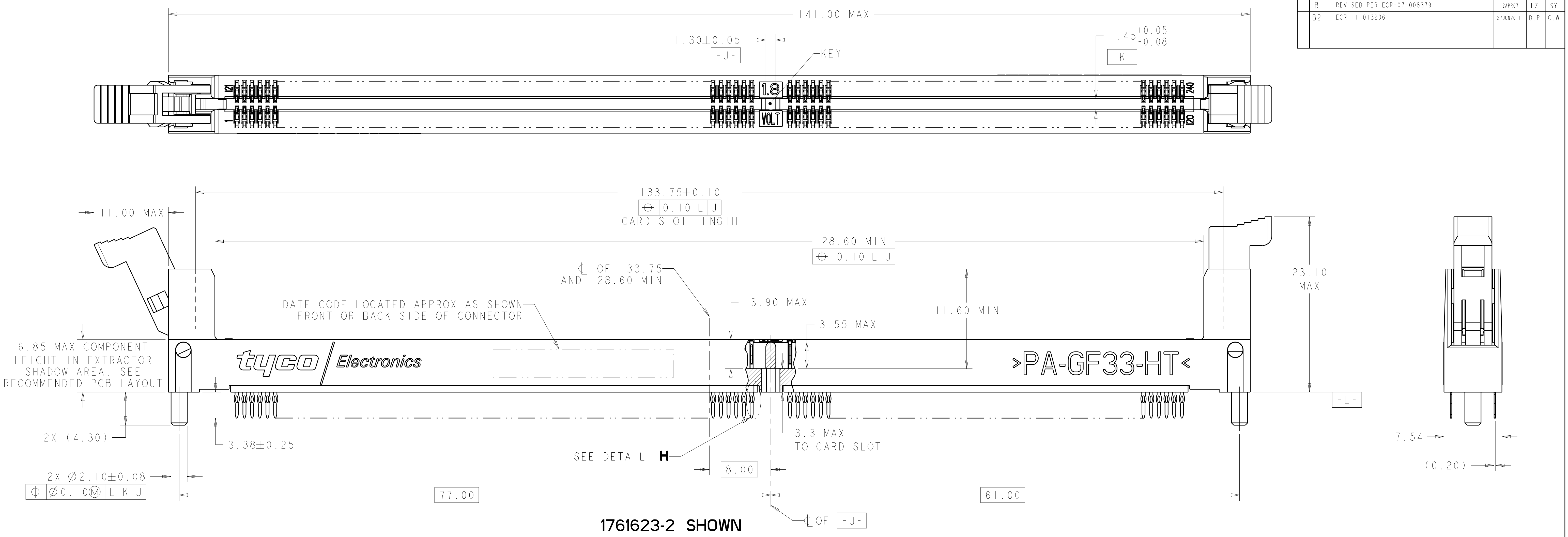
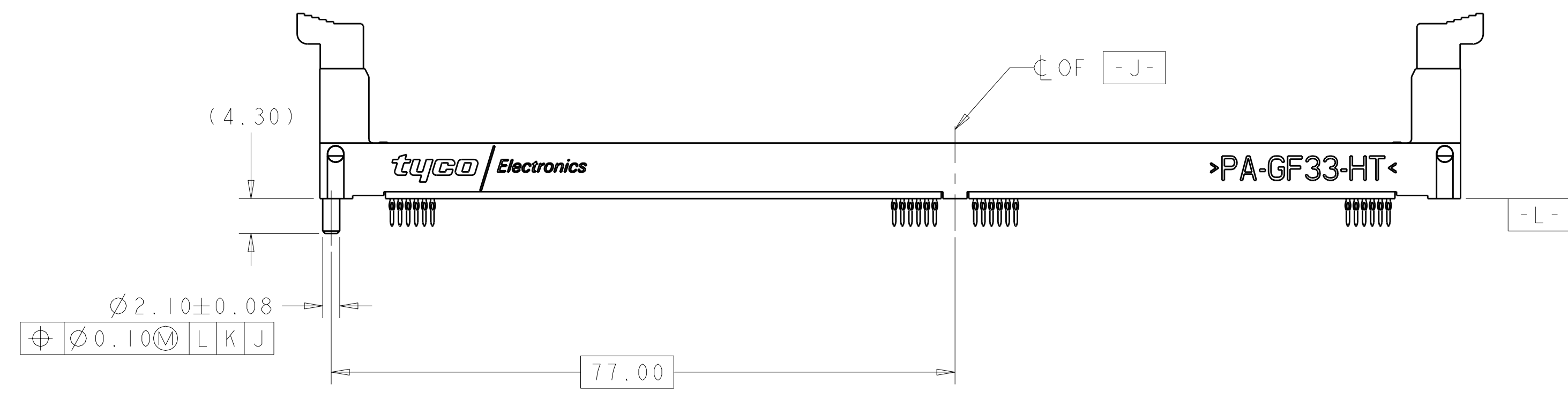

	COMPLIANT PIN	SUPPORT PLATE COLOR	EXTRACTOR COLOR	HOUSING COLOR	DESCRIPTION	PART NUMBER
	⊕	NATURAL	AMBER	NATURAL	1 POST	1761623-5
OBSOLETE	⊕	BLACK	AMBER	BLACK	1 POST	1761623-4
	⊕	BLACK	NATURAL	BLACK	1 POST	1761623-3
	⊕	BLACK	NATURAL	BLACK	2 POSTS	1761623-2
	⊕	BLACK	NATURAL	BLACK	1 POST	1761623-1

DIMENSIONS: mm TOLERANCES UNLESS OTHERWISE SPECIFIED: 9 PLC ±.5 8 PLC ±0.13 5 PLC ±0.13 4 PLC ±0.001 ANGLES ±.		DWN: D. RINGLER 10AUG2006 CHK: J. PENNYPACKER 10AUG2006 APVD: M. ROWERS 22DEC2006	Tyco Electronics Harrisburg, PA 17105-3608
MATERIAL:		PRODUCT SPEC: 108-2245 APPLICATION SPEC: 114-13167 WEIGHT: -	NAME: SOCKET ASSEMBLY, VERTICAL FB DIMM, PRESS FIT, 240 POSITION SIZE: CAGE CODE DRAWING NO: 00779 DRAWING NO: 1761623
FINISH:		CUSTOMER DRAWING SCALE: 4:1 SHEET 1 OF 3 REV: B2	

LOC	DIST	REV	DATE	BY	APPD
GP	00				

REVISIONS			
REV	DATE	BY	APPD
-	-	-	-
-	-	-	-

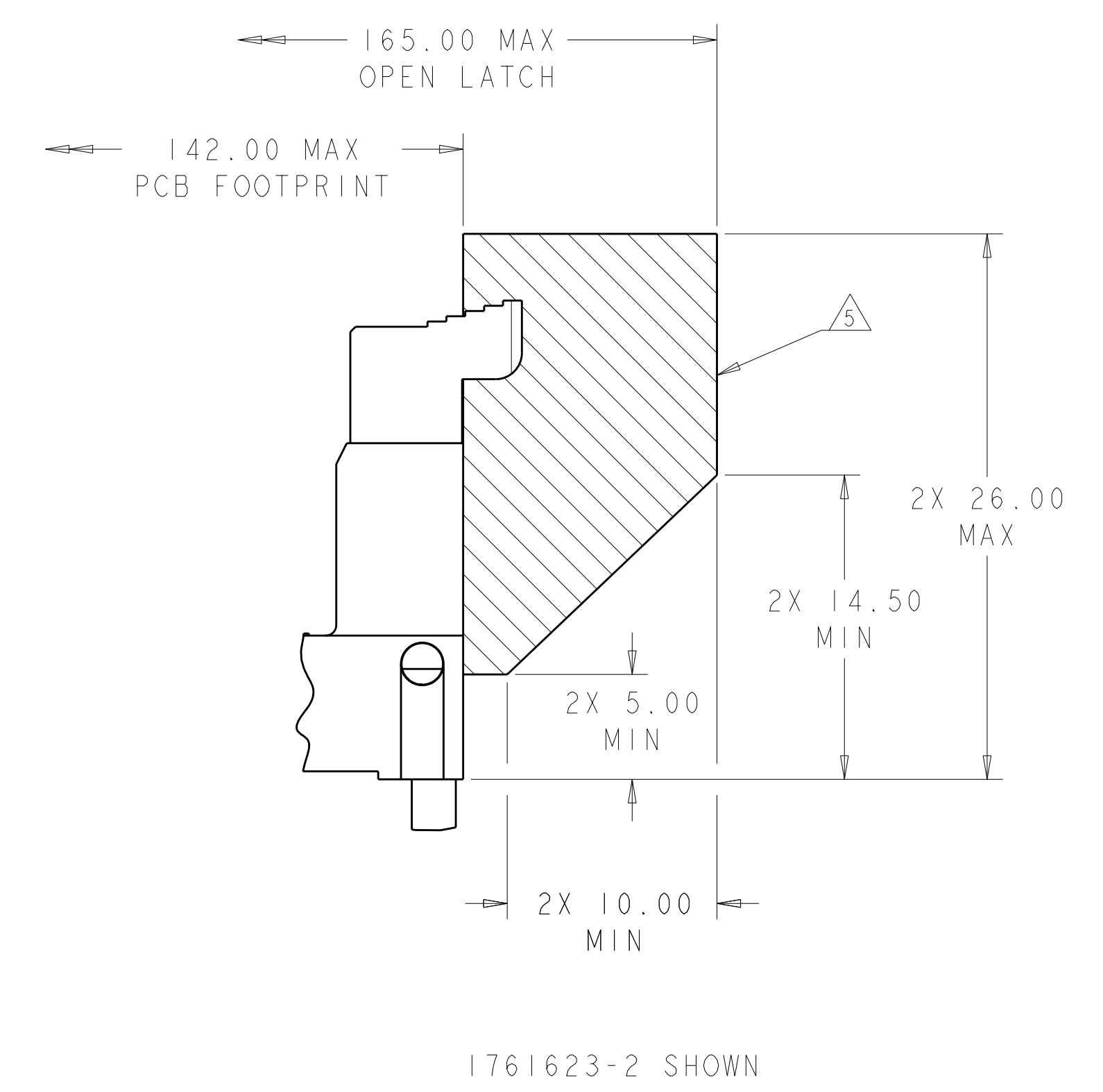
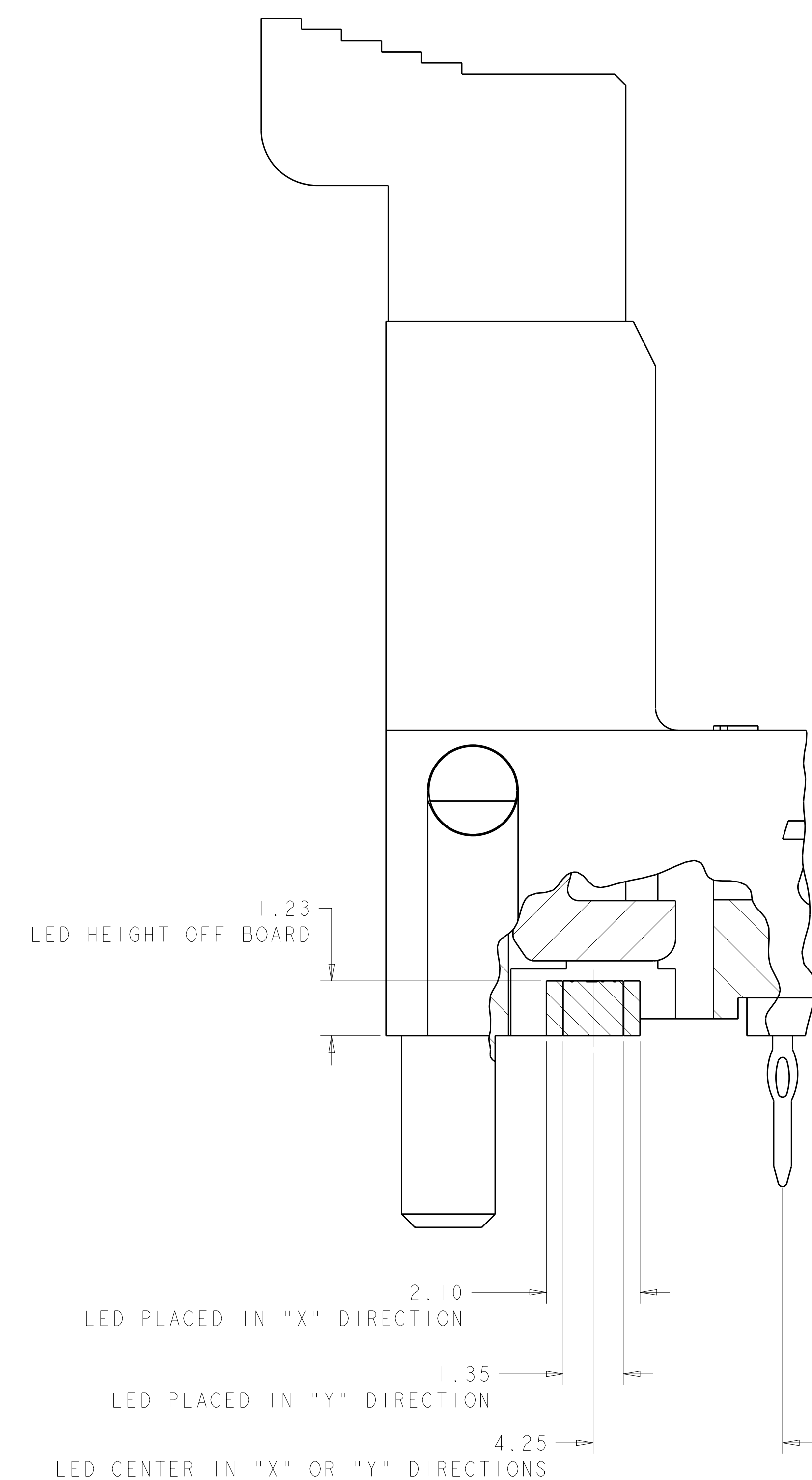
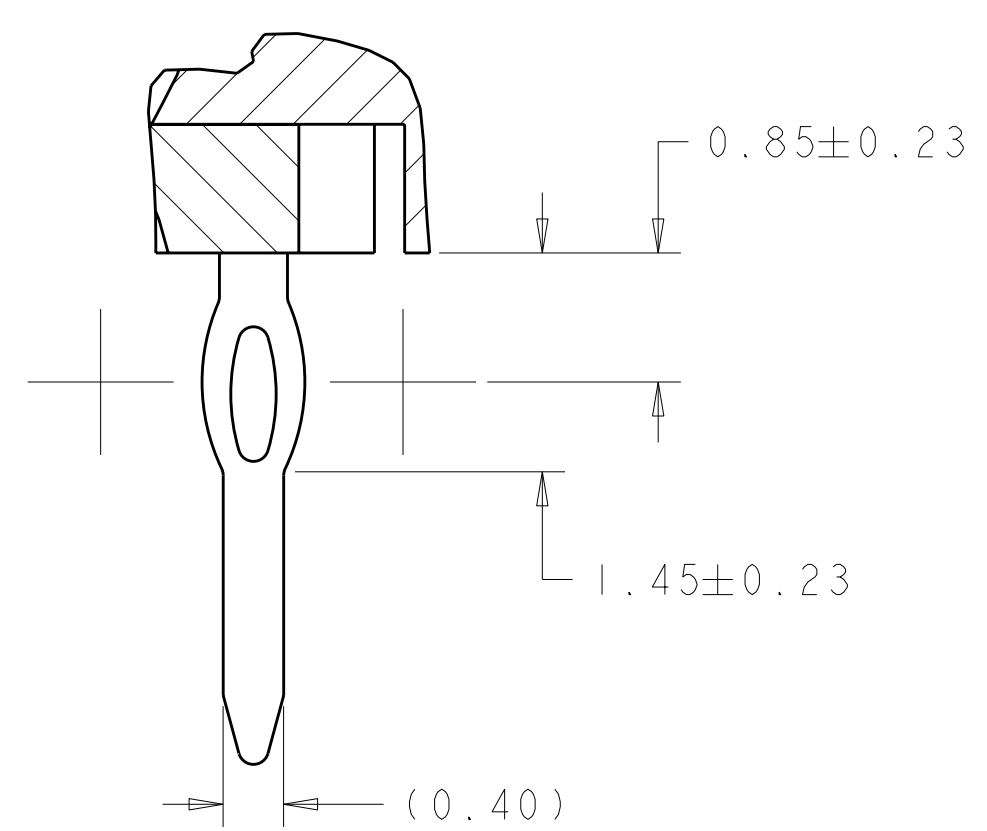
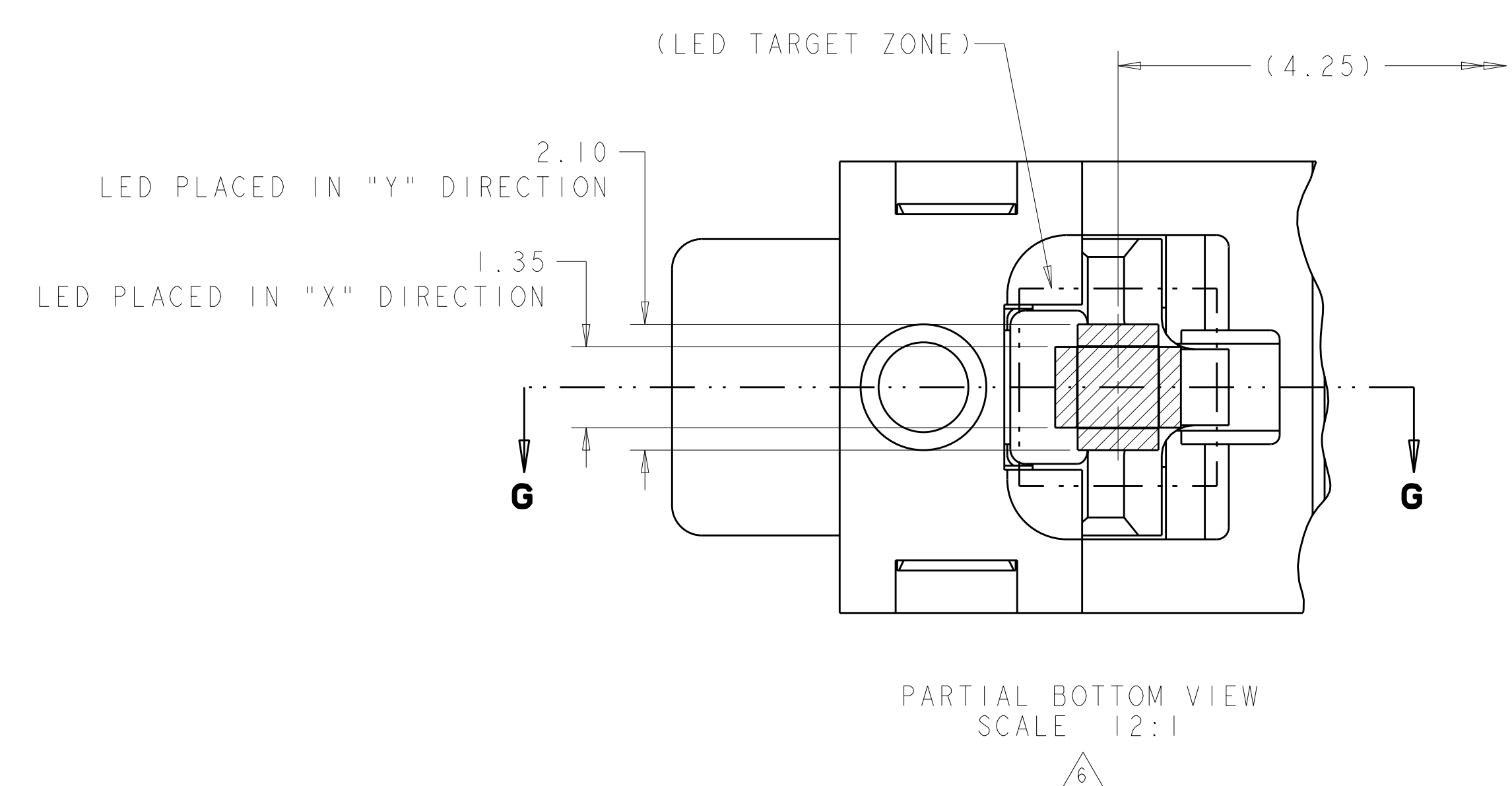

<small>THIS DRAWING IS UNPUBLISHED. RELEASED FOR PUBLICATION. IT IS SUBJECT TO CHANGE WITHOUT NOTICE AND WITHOUT OBLIGATION. SHOULD BE CONTACTED FOR THE LATEST REVISION.</small>		DWN D. RINGLER 10AUG2006 CHK J. PENNYPACKER 10AUG2006 APVD M. ROWERS 22DEC2006	tyco Electronics Tyco Electronics Harrisburg, PA 17105-3608
DIMENSIONS: mm 	TOLERANCES UNLESS OTHERWISE SPECIFIED: 0 PLC ± 1 PLC ±0.5 2 PLC ±0.13 3 PLC ±0.013 4 PLC ±0.001 ANGLES ±0.0001	PRODUCT SPEC 108-2245 APPLICATION SPEC 114-13167 WEIGHT - FINISH -	NAME SOCKET ASSEMBLY, VERTICAL FB DIMM, PRESS FIT, 240 POSITION SIZE CAGE CODE DRAWING NO. RESTRICTED TO A11 00779 C=1761623 CUSTOMER DRAWING SCALE 4:1 SHEET 2 OF 3 REV B2

LOC	DIST	REV	DATE	BY	APPD
GP	00				

REVISIONS		DATE	BY	APPD
1	SEE SHEET 1			

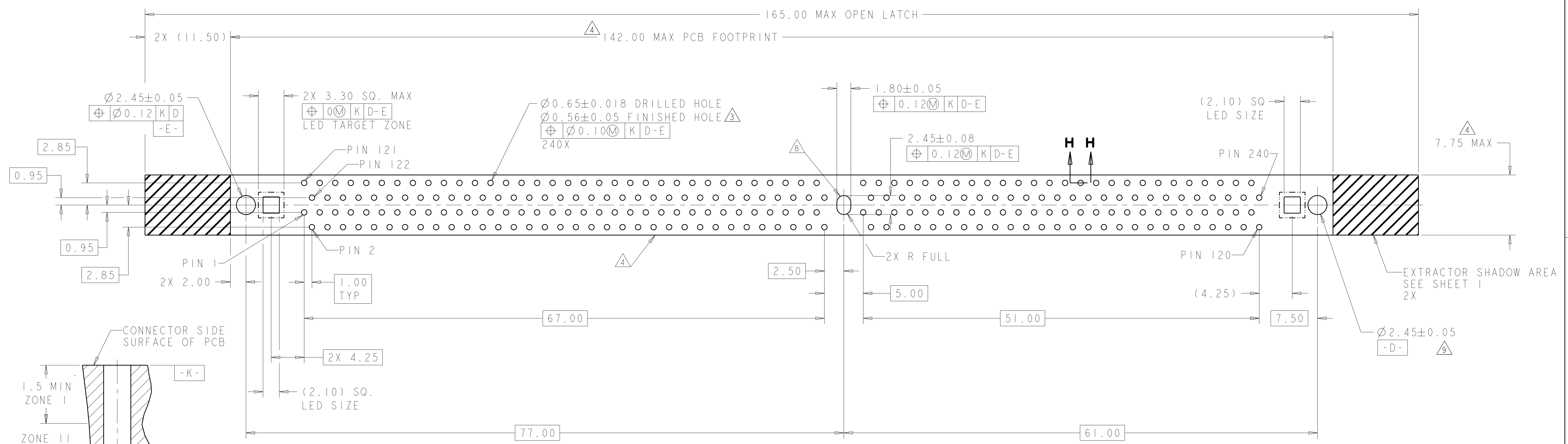

RECOMMENDED PCB LAYOUT
 VIEWED FROM CONNECTOR SIDE
 NOTE: REFER TO JEDEC SO-003 FOR COMPLETE PCB LAYOUT

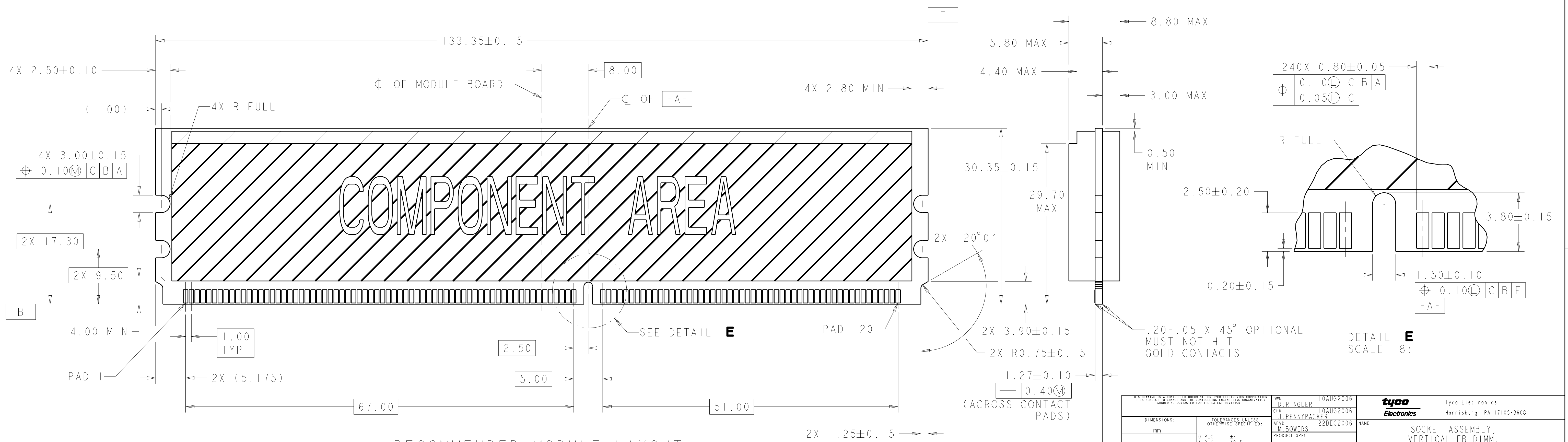

RECOMMENDED MODULE LAYOUT
 SCALE 3:1
 NOTE: REFER TO JEDEC MO-256 FOR COMPLETE MODULE DETAILS.

DIMENSIONS: mm		TOLERANCES UNLESS OTHERWISE SPECIFIED: 9 PLC ±.5 1 PLC ±0.5 5 PLC ±0.13 4 PLC ±0.001 ANGLES ±.001		DWN: D. RINGLER 10AUG2006 CHK: J. PENNYPACKER 10AUG2006 APVD: M. ROWERS 22DEC2006		tyco Electronics Tyco Electronics Harrisburg, PA 17105-3608	
MATERIAL:		FINISH:		PRODUCT SPEC: 108-2245 APPLICATION SPEC: 114-13167 WEIGHT:		NAME: SOCKET ASSEMBLY, VERTICAL FB DIMM, PRESS FIT, 240 POSITION SIZE: A11 CAGE CODE: 00779 DRAWING NO: C=1761623	
CUSTOMER DRAWING				SCALE: 4:1		SHEET: 3 OF 3 REV: B2	