

RECOMMENDED P.C.B. LAYOUT
SCALE 3:1

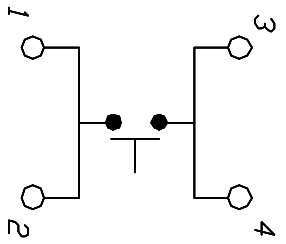

CIRCUIT: SPST

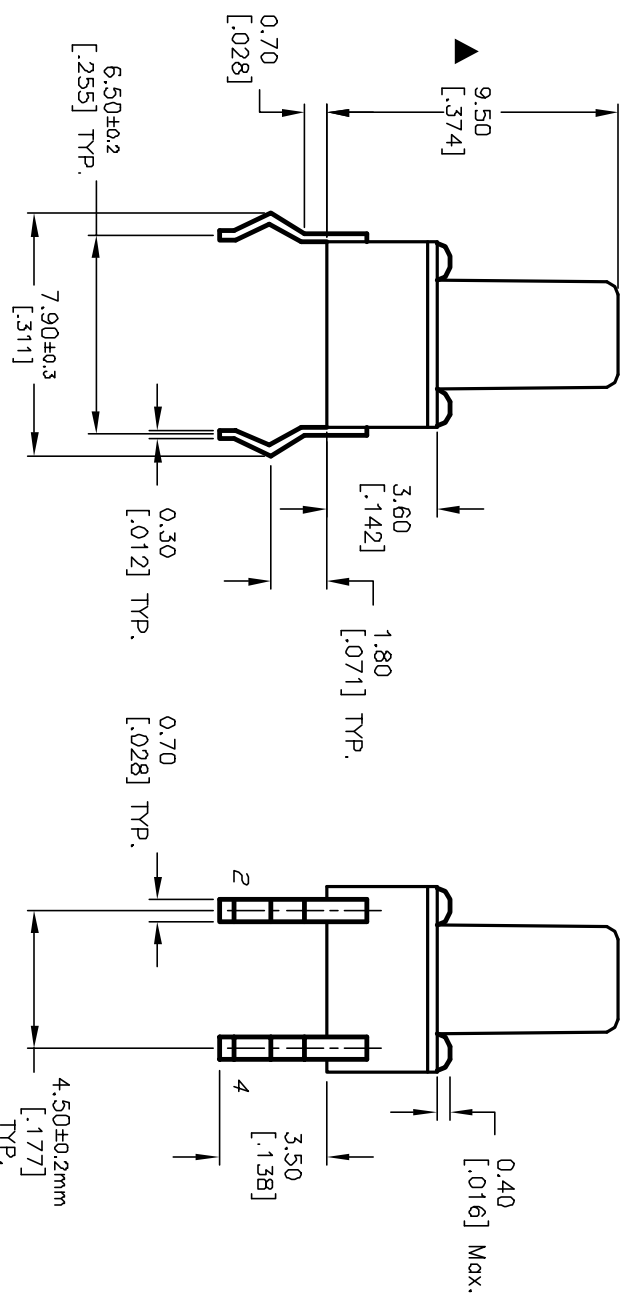

NOTES:

1. ALL DIMENSIONS IN MM [INCH]
2. GENERAL TOLERANCE: X.X=±0.4 X.XX=±0.25
3. TERM. NOS. FOR REFERENCE ONLY.
4. RATINGS: 12VDC, 50mA
5. OPERATING FORCE: 250±50gf
6. TRAVEL: 0.25±0.1mm
7. CONTACT RESISTANCE: 100 MILLI Ω Max.
8. DIELECTRIC STRENGTH: 250V RMS min.
9. INSULATION RESISTANCE: 100 Mega Ω min.
10. ELECTRICAL LIFE: 100,000 CYCLES min.
11. DESIGNATE MAJOR FEATURE:

REV.	ECN No.	DESCRIPTION	DATE	CHKD
A	11621	RELEASED FOR PRODUCTION	8/22/01	CJB

TITLE	SCALE	DATE	DR	DWG	REV
TL1105B F250 Q	4:1	8/22/01	CJB	D310043	A

E-SWITCH®

THE INFORMATION CONTAINED IN THIS DOCUMENT IS PROPRIETARY TO E-SWITCH AND IS NOT TO BE COPIED OR TRANSFERRED