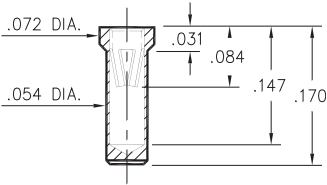
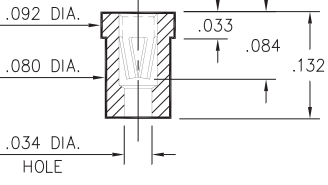
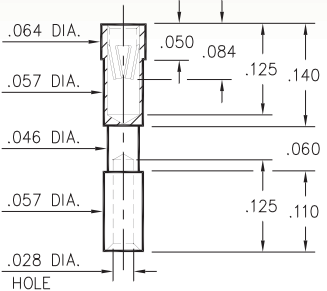
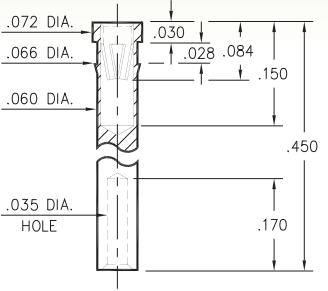
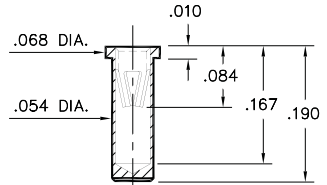

PIN RECEPTACLES

FOR .020" - .032" DIAMETER PINS

<p>0338 0338-0-15-XX-15-XX-10-0 Solder mount in .057 min. mounting hole Also available on 12mm wide carrier tape: 1,700 parts per 13" reel Order as: 0338-0-57-XX-15-XX-10-0</p> 	<p>0378 0378-0-15-XX-15-XX-10-0 Solder mount in .082 min. mounting hole</p> 	<p>6002 6002-0-19-XX-15-XX-10-0 Solder mount in .059 min. mounting hole</p> 	<p>7009 7009-0-19-XX-15-XX-10-0 Press-fit in .063 mounting hole</p> 
<p>0339 0339-0-15-XX-15-XX-10-0 Solder mount in .057 min. mounting hole</p> 			

SPECIFICATIONS:

Shell Material: Brass Alloy 360, 1/2 Hard
Contact Material: Beryllium Copper Alloy 172, HT
Dimensions: Inches
Tolerances On: Lengths: ±.005
 Diameters: ±.002
 Angles: ± 2°



ORDER CODE: XXXX - X - 1X - XX - 15 - XX - 10 - 0

BASIC PART #

SPECIFY SHELL FINISH:

- 01 200 μ" TIN/LEAD OVER NICKEL
- ◆ 80 200 μ" TIN OVER NICKEL (RoHS)
- ◆ 15 10 μ" GOLD OVER NICKEL (RoHS)

SPECIFY CONTACT FINISH:

- 01 200 μ" TIN/LEAD OVER NICKEL
- ◆ 80 200 μ" TIN OVER NICKEL (RoHS)
- ◆ 27 30 μ" GOLD OVER NICKEL (RoHS)

SELECT CONTACT:

#15 CONTACT (DATA ON PAGE 254)

(For alternate contact choices, see group K on page 248)

