

I²C-Bus INTERFACE REAL TIME CLOCK MODULE

RX-8581 SA/ JE/ NB

- Built-in frequency adjusted 32.768 kHz crystal unit.
- Interface Type : I²C-Bus Interface (400 kHz)
- Operating voltage range : 1.8 V to 5.5 V
- Wide Timekeeper voltage range : 1.6 V to 5.5 V
- Low backup current : 0.45 μA / 3 V (Typ.)
- 32.768 kHz frequency output function : C-MOS output With Control Pin
- The various functions include full calendar, alarm, timer.

* The I²C-Bus is a trademark of NXP Semiconductors



Product Number (Please contact us)
 RX-8581SA : Q41858152xxxx00
 RX-8581JE : Q41858171xxxx00
 RX-8581NB : Q41858192000200



Actual size



Block diagram

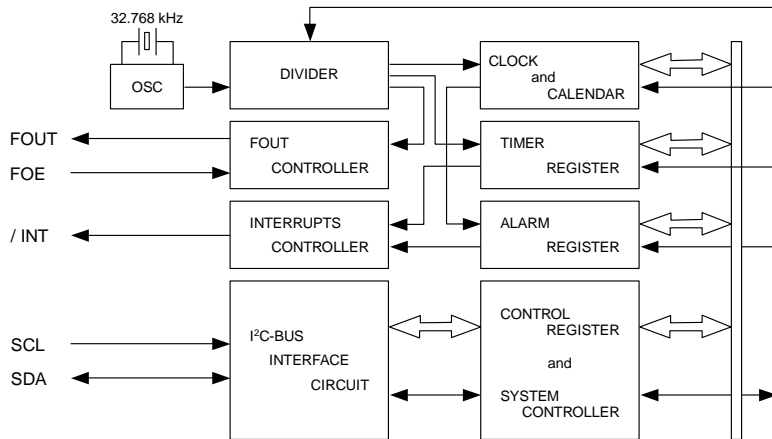

Overview

- **Interface Type**
 - I²C-Bus interface. (Hi-speed bus specifications 400 kHz)
 - * I²C-Bus slave address : read A3h and write A2h
- **32.768 kHz frequency output function**
 - FOUT pin output (C-MOS output), CL=30 pF
 - 32.768 kHz clock frequency output. (Duty 50 ±5 %)
- **Timer function**
 - Timer interrupt function can be set up between 1/4096 second and 4095 minutes.
 - It is recorded automatic to TF-bit at the time of event occurrence, and possible to output with /TIRQ pin output (N-ch open-drain output).
- **Interrupt function**
 - Alarm interrupt function, Time update interrupt function.

Terminal connection / External dimensions

(Unit:mm)

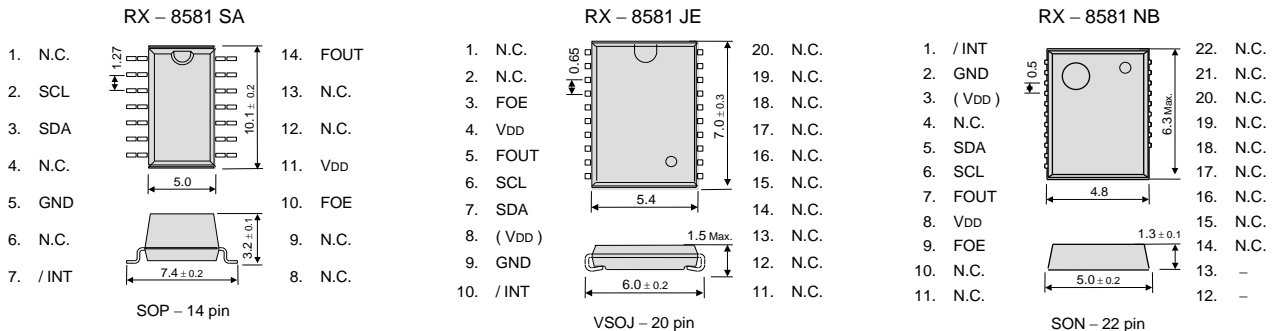

Metal may be exposed on the top or bottom of this product. This will not affect any quality, reliability or electrical spec.

Specifications (characteristics)

* Refer to application manual for details.

Recommended Operating Conditions

Item	Symbol	Condition	Min.	Typ.	Max.	Unit
Power voltage	V _{DD}	—	1.8	3.0	5.5	V
Clock voltage	V _{CLK}	—	1.6	3.0	5.5	V
Operating temperature	T _{OPR}	—	-40	+25	+85	°C

Frequency characteristics

Item	Symbol	Condition	Rating	Unit
Frequency tolerance	Δ f / f	T _a = +25 °C V _{DD} = 3.0 V	5 ± 23 *	× 10 ⁻⁶
FOUT output Duty	tw / t	T _a = -40 °C to +85 °C V _{DD} = 2.4 V to 5.5 V	50 ± 5	%

* Please ask for tighter tolerance. (Equivalent to 1 minute of monthly deviation)

Current consumption characteristics

T_a = -40 °C to +85 °C

Item	Symbol	Condition	Min.	Typ.	Max.	Unit
Current Consumption	I _{BK}	f _{SCL} = 0 Hz FOE = GND	V _{DD} = 5 V	0.65	1.2	μA
		FOUT ; output OFF (LOW)	V _{DD} = 3 V	0.45	0.8	
	I _{32k}	f _{SCL} = 0 Hz FOE = V _{DD}	V _{DD} = 5 V	8.0	20.0	μA
		FOUT ; 32.768 kHz output ON CL = 30 pF	V _{DD} = 3 V	5.0	12.0	