

μMP Series

Up to 1200 Watts

Total Power: Up to 1200 Watts
Input Voltage: 85 - 264 Vac
120-300 Vdc
of Outputs: Up to 12

Special Features

- Full Medical EN60601 approval
- PMBus
- High efficiency
- Current limit modification (foldback or constant current)
- High power density.
 - uMP4: 10.8 W/cu-in
 - uMP1: 15.1 W/cu-in
- Intelligent fan (speed control/fault status)
- Downloadable GUI from website
- uP controlled PFC input with active inrush protection
- Optional conformal coating
- Industrial temp range (-40 °C to 70 °C)
- No preload required
- Industrial shock/vibration (> 50G's)
- Low cost
- IEC or terminal block input
- Low profile 1U size

Safety

- **UL** UL60950/UL60601-1
- **CSA** CSA22.2 No. 234 Level 5
- **VDE** EN60950/EN60601-1
- **BABT** Compliance to EN60950/EN60601 BS7002
- **CB** Certificate and report
- **CE** Mark to LVD
- **CCC** Approved

MicroMP 1U Multi Output



μMP4C shown



Electrical Specifications

Input	
Input range:	85 - 264 Vac, 120 - 350 Vdc (limited to 250 Vac/300 Vdc in medical apps)
Frequency:	47 - 440 Hz
Inrush current:	40 A peak max. (soft start)
Efficiency:	Up to 91% @ full case load
Power Factor:	0.99 typ. meets EN61000-3-2 (n/a @ 440 Hz)
Turn-on time:	AC on 2 sec for uMP1 and 1.5 sec for uMP4, inhibit/enable 250 ms typical
EMI filter:	CISPR 22/EN55022 Level "B"
Leakage current:	300 μA Max. @ 240 VAC
Radiated EMI:	CISPR 22/EN55022 Level "B"
Holdover storage:	16.7 ms minimum (independent of input Vac, 0 °C to 50 °C)
AC OK:	Signal goes low indicating loss of AC input. Hold up = Full cycle ride thru (50 Hz)
Harmonic distortion:	Meets EN61000-3-2
Isolation:	Meets EN60950 and EN60601
Global Inhibit/Enable:	TTL, Logic "1" and Logic "0"; fan off when unit is inhibited
Input fuse (internal):	uMP1: 16 A/250 V TLAG, uMP4: 10 A / 250 V. (both lines fused)
Warranty:	2 years

Environmental Specifications

Operating temperature:	-40 ° to 70 °C ambient. Derate each output 2.5% per degree from 50 °C to 70 °C. (-20 °C start up). Meets full spec after 1/2 load. 10 min warm-up
Storage temperature:	-40 °C to 85 °C
Electromagnetic susceptibility:	Designed to meet EN61000-4; -3, -5, -6, -11 Level 3, Level 4 for -2, -4
Humidity:	Operating; non-condensing 10% to 95% RH
Vibration:	MIL-STD-810E
MTBF demonstrated:	> 350,000 hours at full load, one uMP4 case + two modules, Telcordia SR-332 calculated MTBF
Altitude:	Up to 10k feet; derate linear to 50% from 10k-30k feet

Output

Factory set point accuracy:	± 1%
Margining:	± 3 - 7% nominal analog (single output module only)
Overall regulation:	0.4% or 30 mV whichever is greater.
Ripple:	RMS: 0.1% or 10 mV, whichever is greater Pk-Pk: 1.0% or 50 mV, whichever is greater. Bandwidth limited to 20 MHz
Dynamic response:	< ± 5% or 250 mV, with 50% step load
Recovery time:	To within 1% in < 300 μsec
Reverse voltage protection:	100% of rated output current
Thermal protection: (OTP)	All outputs disabled when internal temp exceeds safe operating range.
Remote sense:	Up to 0.5 V total drop (not available on triple output module)
Single wire parallel:	Current share to within 5% of total rated current
DC OK:	± 5% of nominal.
Minimum load:	Not required
Housekeeping standby:	5 Vdc @ 1.0 A max. present whenever AC input is applied
Module inhibit:	Logic - output on with low or open. Different logic options available
Output/Output isolation:	> 1 Megohm, 500 V

Vout	Full load (A)	OVP trip max (V)	OCP trip typ (I-out%)	SCP trip max (I-out%)	Overshoot (max mV)	Peak Deviation (max mV)
3V3 Module						
0.9	40	TBD	130%	160%	150	± 250
3.3	40	5.96 V	130%	160%	250	± 250
3.6	40	6.32 V	130%	160%	250	± 250
5 V Module						
3.2	36	6.8 V	130%	160%	250	± 250
5	36	8.8 V	130%	160%	250	± 250
6	30	9.2 V	130%	160%	300	± 300
12 V Module						
6	25	12 V	130%	160%	300	± 300
12	20	18 V	130%	160%	600	± 600
15	16	20 V	130%	160%	750	± 750
24 V Module						
12	13	18 V	130%	160%	600	± 600
24	10	31 V	130%	160%	1200	± 1200
30	8	38 V	130%	160%	1500	± 1500
48 V Module						
28	7	TBD	130%	200%	1400	± 1400
48	5	TBD	130%	160%	2400	± 2400
60	4	TBD	130%	200%	3000	± 3000

Case Line-Up

Case	Max Output	Dimensions	Connections	Max Current Amps
μMP4 - 4 Slot	400 W - 600 W	256.9±0.8 x 88.9±0.5 x 40.0±0.7 (10.11" x 3.5" x 1.57")	IEC/Terminal Block	9.91
μMP1 - 6 Slot	1000 W - 1200 W	256.9±0.8 x 127±0.5 x 40.0±0.5 (10.11" x 5" x 1.57")	IEC/Terminal Block	13.87

Output Module Line-Up

Output Range (Vdc)	Max Current (Amps)	Max Power (Watts)	Module Codes Standard Outputs
0.9 - 3.6	40	144	A, B, C, D - 2, 2.2, 3, 3.3
3.2 - 6.0	36	180	E, F, G, H - 5, 5, 2, 5.5, 6
6.0 - 15.0	25	240	I, J, K, L, M, N - 8, 10, 11, 12, 14, 15
12.0 - 30.0	13	240	O, P, Q, R, S - 18, 20, 24, 28, 30
28.0 - 54.0	7	240	T, U, V, W, X, Y - 28, 30, 33, 36, 42, 48, 54, 60
5.0 - 28.0	4	96	Dual Output Module. Each output is rated to 96W (192 Watts total). Wide range is adjustable.
5.0 - 28.0	4	96	

Ordering Info

Case Size	Module/Voltage/Option Codes	Case Option Codes	Software Code	Hardware Code
μMPXY	S2E - DER - DLL	00	A	###
Case Size Single - Phase Input where X = 4 = 1.57" x 3.5" x 10"; 400 W - 600 W, 4 Slots 1 = 1.57" x 5" x 10"; 1000 W - 1200 W, 6 Slots Input Type where Y = T = Terminal Block C = IEC Connector, C14 B = IEC Connector, C16	Module Codes S2 = 200 W Single O/P (1 slot) D = 96 W/96 W Dual O/P Common Ground (1 slot) I = 96 W/96 W Dual O/P Isolated Ground (1 slot) Voltage Codes: See Voltage Code Table	Case Option Codes First digit 0 - F = Parallel Code Second digit 0 = No Options 1 = Reverse Air 3 = Global Enable 5 = Opt 1 + Opt 3	Factory assigned for modified standards	Factory assigned for modified standards

Parallel Codes

Code	Slots in Parallel	Code	Slots in Parallel	Code	Slots in Parallel	Code	Slots in Parallel
1	1&2	6	1,2&3	B	1,2&3; 4&5	0	no module in parallel
2	2&3	7	1,2,3&4	C	1,2,3&4; 5&6		
3	3&4	8	1,2,3,4&5	D	1&2; 3&4; 5&6		
4	4&5	9	1,2,3,4,5&6	E	1,2&3; 4,5&6		
5	5&6	A	1&2; 3&4	F	2&3; 4&5		

Application Notes

- (Only for Output Voltages 14.0V-24.0V)
- Units should not be operated in parallel
 - In a single unit, parallel modules should not be individually inhibited
 - Total load capacitance should not exceed 2000uF

Voltage Codes

Standard Output Ratings		
Module Output Voltage Code	Single Output ONE SLOT 240 Watts Max	Dual Output ONE SLOT 192 Watts Max
Module Identification	S2	D = Dual Common Ground I = Dual Isolated Ground

Output Module Line-Up

Code	Volts	Output Current V1	Output Current	
			V1	V2
A	2.0V	40.0	N/A	N/A
B	2.2V	40.0	N/A	N/A
C	3.0V	40.0	N/A	N/A
D	3.3V	40.0	4.0*	4.0*
E	5.0V	36.0	4.0	4.0
F	5.2V	34.0	4.0	4.0
G	5.5V	32.0	4.0	4.0
H	6.0V	30.0	4.0	4.0
I	8.0V	25.0	4.0	4.0
J	10.0V	24.0	4.0	4.0
K	11.0V	22.0	4.0	4.0
L	12.0V	20.0	4.0	4.0
M	14.0V	17.0	4.0	4.0
N	15.0V	16.0	4.0	4.0
O	18.0V	13.0	4.0	4.0
P	20.0V	12.0	4.0	4.0
Q	24.0V	10.0	4.0	4.0
R	28.0V	8.6	3.4	3.4
S	30.0V	8.0	N/A	N/A
T	33.0V	7	N/A	N/A
U	36.0V	6.7	N/A	N/A
V	42.0V	5.7	N/A	N/A
W	48.0V	5.0	N/A	N/A
X	54.0V	4.4	N/A	N/A
Y	60.0V	4.0	N/A	N/A

* For "I" codes only

Derating Curves - μMP1

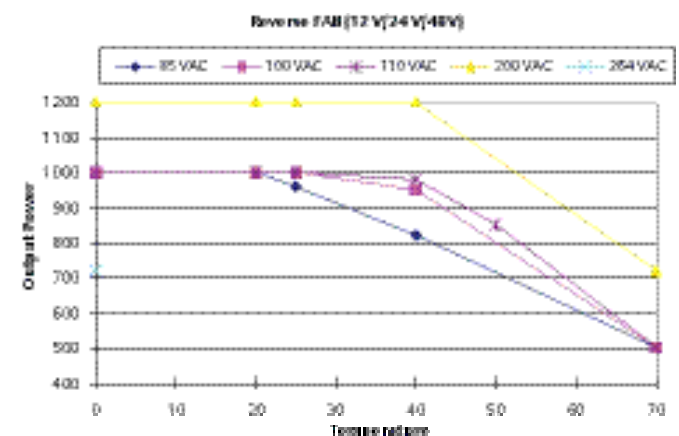
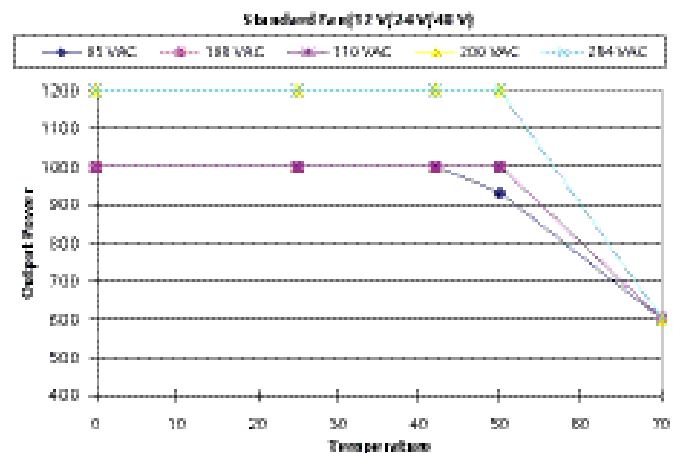

S2 Module

μMP4 (AC input on opposite side)

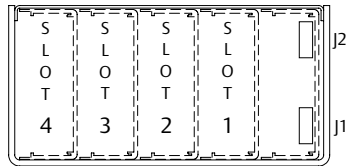

Input
 μMP4 = 4 available slots 85-264 Vac 200-264 Vac
 400 W max. 600 W max.

μMP1 (AC input on opposite side)

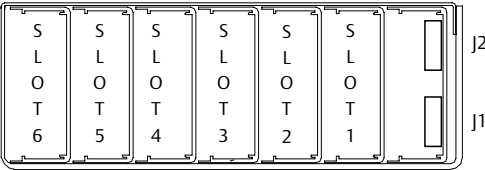

Input
 μMP1 = 6 available slots 85-264 Vac 200-264 Vac
 1000 W max. 1200 W max.

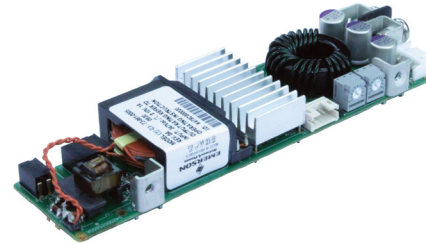

240 W

DC Output Control & Signals (Single output)

Pin	Function
1	No connection
2	No connection
3	Current share
4	Module inhibit return
5	Module ISO inhibit
6	SCOM
7	-RMT sense
8	Margin
9	Remote margin / V prog.
10	+RMT sense

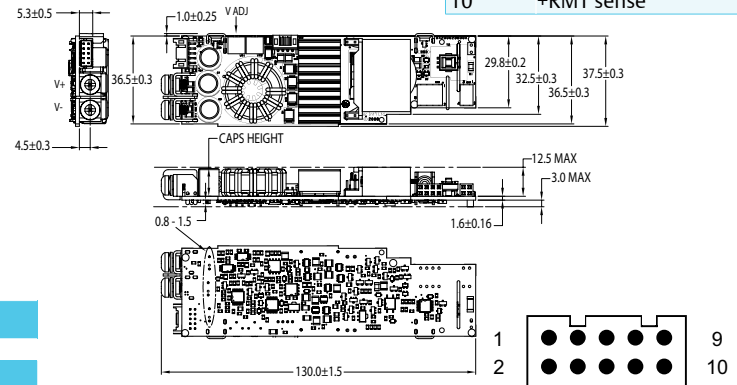

Pin Connectors

Figure 1. AC Input



IEC Connector



Terminal Block

PEN L

AC Input

Pin	Function
1	AC neutral
2	AC line (hot)
3	Chassis (earth) ground

J1 PFC Input Connector (control & signals)

Pin	Function
1	Input AC OK - "emitter"
2	Input AC OK - "collector"
3	Global DC OK - "emitter"
4	Global DC OK - "collector"
5	Spare
6	Global inhibit/optional enable logic "1"
7	Global inhibit/optional enable logic "0"
8	Global inhibit/optional enable return
9	+5 VSB housekeeping
10	+5 VSB housekeeping return

Figure 2. Connector J1 & J2

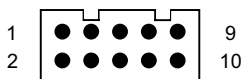

Mates with
 Landwin 2050S1000 Housing
 2053T011V Pin

OR

JST PHDR-10VS Housing
 JST SPHD-002T-P0.5 (28-24)
 JST SPHD-001T-P0.5 (26-22)

Connector Kit Part No.:
 70-841-023

J2 PC Bus Output Connector

Pin	Function
1	5 Vcc bus
2	Serial data signal (SDA)
3	Secondary return (COM)
4	Serial clock signal (SCL)
5	Address bit 2 (A2)
6	No connection
7	Address bit 1 (A1)
8	No connection
9	Address bit 0 (A0)
10	No connection

Dual Module



DC Output Control & Signals (Dual output)

Pin	Function
1	-RMT sense V2
2	+RMT sense V2
3	No connection
4	Module inhibit rtn
5	Module ISO inhibit
6	SCOM
7	-RMT sense V1
8	No connection
9	No connection
10	+RMT sense V1

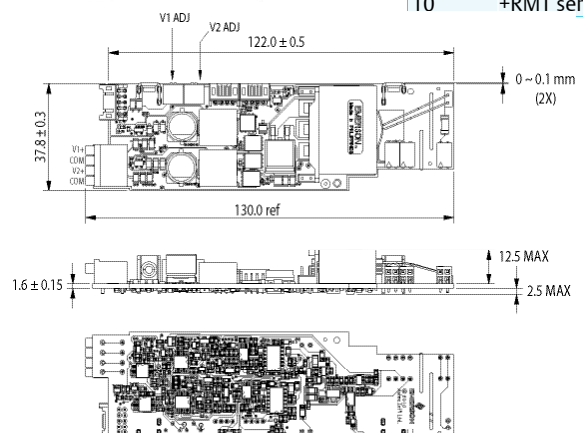

μMP Series
μMP4 (400/600 Watts Max)

Case Size: μMP4: 10.11" x 3.5" x 1.57" (256.9mm x 88.9mm x 40.0mm)
Weight: μMP4 Case: 1.96 lbs • Single O/P: 0.22 lb. • Dual O/P: 0.16 lb.
• Blank: 0.06 lb.

Rev. 4.10.2013
μMP Series
5 of 6

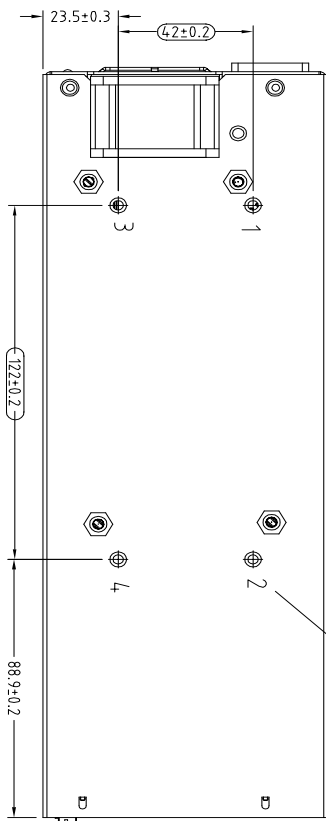
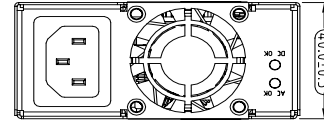

FOR M4 SCREW SYSTEM MOUNTING.
MAX. TORQUE 1.0Nm.
MAX 3.5 mm SCREWED IN.

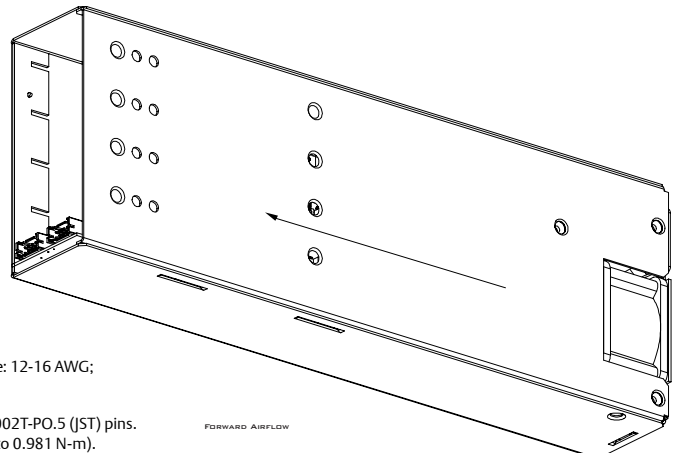
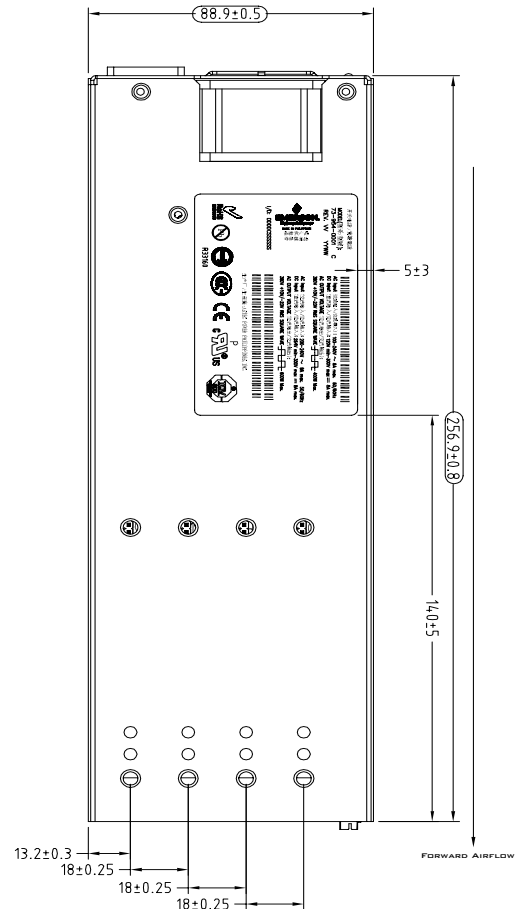
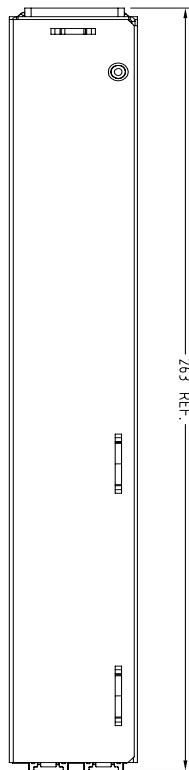

Notes:

- Input: IEC 60320 C13 (for IEC connector)
Barrier Type DECA Switchlab MT300-50003 (for terminal block connector); Max Torque: 4.0 lb-in (0.4-0.5 Nm); Wire: 12-16 AWG;
Wire Strip Length: 0.354" (9.0 mm)
- Control Connectors (J1 and J2): 10-position housing, brass, matte tin-plated contacts.
Mates with housing 2050S1000 (Landwin) with 2053T011P (Landwin) pins or housing PHDR-IOVS (JST) and SPHD-002T-PO.5 (JST) pins.
- Output Module Connectors: All single O/P modules are M4 x 10mm screws; Max. Torque: 6.94 to 8.68 lb-in (0.785 to 0.981 N-m).
Dual O/P module is PUSH IN conductor connector; Wire Strip Length: 0.315" (8.0 mm); Control signal connector: Refer to Item 2.
- Chassis Material: Steel with chemical film coating (conductive).
- Customer Mounting: Screw M4-type mounting holes; Max. Penetration is 0.138" (3.5 mm); Max. Torque: 8.85 lb-in (1.0 N-m)
- All dimensions are in millimeters and inches, and are typical.

μMP Series
 μMP1 (1000/1200 Watts Max)

Case Size: μMP1: 10.11" x 5" x 1.57" (256.9mm x 127mm x 40.0mm)
 Weight: μMP1 Case: 2.78 lbs • Single O/P: 0.22 lb.
 • Dual O/P: 0.16 lb. • Blank: 0.06 lb.

Americas
 5810 Van Allen Way
 Carlsbad, CA 92008
 USA
 Telephone: +1 760 930 4600
 Facsimile: +1 760 930 0698

Europe (UK)
 Waterfront Business Park
 Merry Hill, Dudley
 West Midlands, DY5 1LX
 United Kingdom
 Telephone: +44 (0) 1384 842 211
 Facsimile: +44 (0) 1384 843 355

Asia (HK)
 14/F, Lu Plaza
 2 Wing Yip Street
 Kwun Tong, Kowloon
 Hong Kong
 Telephone: +852 2176 3333
 Facsimile: +852 2176 3888

For global contact, visit:
www.Emerson.com/EmbeddedPower
techsupport.embeddedpower@emerson.com

While every precaution has been taken to ensure accuracy and completeness in this literature, Emerson Network Power assumes no responsibility, and disclaims all liability for damages resulting from use of this information or for any errors or omissions.

Emerson Network Power.
 The global leader in enabling business-critical continuity.

- AC Power
- Connectivity
- DC Power
- Embedded Computing
- Embedded Power**
- Monitoring
- Outside Plant
- Power Switching & Controls
- Precision Cooling
- Racks & Integrated Cabinets
- Services
- Surge Protection

EmersonNetworkPower.com

Emerson and the Emerson Network Power logo are trademarks of Emerson Electric Co. ©2012 Emerson Electric Co. All rights reserved.

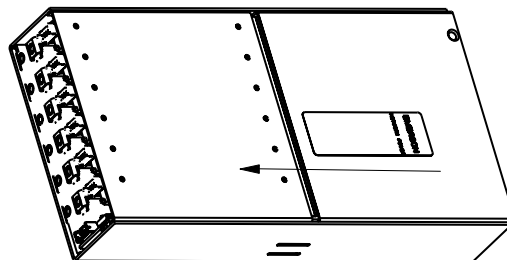
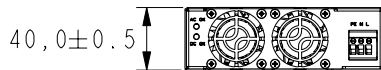
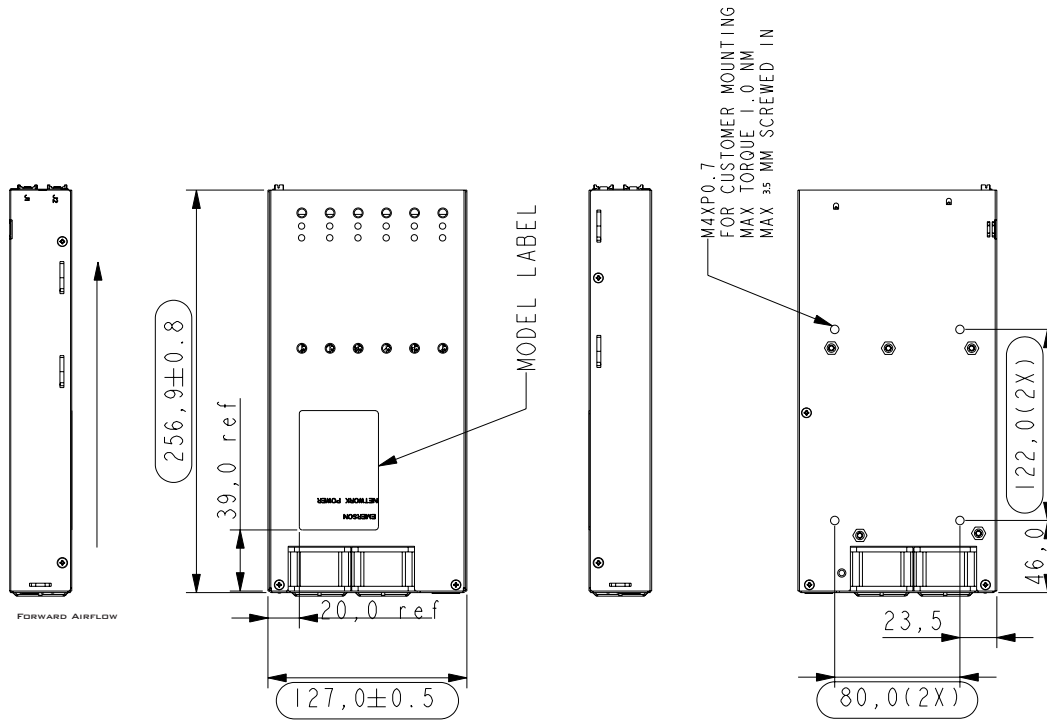

- Notes:
- Input: IEC 60320 C13 (for IEC connector)
 Barrier Type DECA Switchlab MT300-50003 (for terminal block connector); Max Torque: 4.0 lb-in (0.4-0.5 Nm); Wire: 12-16 AWG; Wire Strip Length: 0.354" (9.0 mm)
 - Control Connectors (J1 and J2): 10-position housing, brass, matte tin-plated contacts. Mates with housing 2050S1000 (Landwin) with 2053T011P (Landwin) pins or housing PHDR-IOVS (JST) and SPHD-002T-PO.5 (JST) pins.
 - Output Module Connectors: All single O/P modules are M4 x 10mm screws; Max. Torque: 6.94 to 8.68 lb-in (0.785 to 0.981 N-m).
 Dual O/P module is PUSH IN conductor connector; Wire Strip Length: 0.315" (8.0 mm); Control signal connector: Refer to Item 2.
 - Chassis Material: Steel with chemical film coating (conductive).
 - Customer Mounting: Screw M4-type mounting holes; Max. Penetration is 0.138" (3.5 mm); Max. Torque: 8.85 lb-in (1.0 N-m)
 - All dimensions are in millimeters and inches, and are typical.