

**SPDT UltraCMOS™**  
**10 MHz - 3 GHz RF Switch**

### Features

- Single-pin or complementary CMOS logic control inputs
- +3.0-volt power supply needed for single-pin control mode
- Low insertion loss: 0.7 dB at 1000 MHz, 0.9 dB at 2000 MHz
- Isolation of 32 dB at 1000 MHz, 23 dB at 2000 MHz
- Typical input 1 dB compression point of +27 dBm
- Ultra-small SC-70 package

### Product Description

The PE4242 UltraCMOS™ RF Switch is designed to cover a broad range of applications from 10 MHz through 3 GHz. This reflective switch integrates on-board CMOS control logic with a low voltage CMOS-compatible control interface, and can be controlled using either single-pin or complementary control inputs. Using a nominal +3-volt power supply voltage, a typical input 1 dB compression point of +27 dBm can be achieved.

The PE4242 RF Switch is manufactured on Peregrine's UltraCMOS™ process, a patented variation of silicon-on-insulator (SOI) technology on a sapphire substrate, offering the performance of GaAs with the economy and integration of conventional CMOS.

**Figure 1. Functional Diagram**

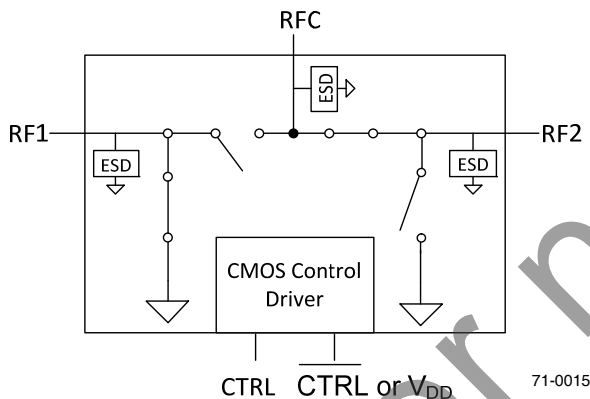

**Figure 2. Package Type**

6-lead SC-70



**Table 1. Electrical Specifications @ +25 °C, V<sub>DD</sub> = 3 V (Z<sub>S</sub> = Z<sub>L</sub> = 50 Ω)**

Parameter	Conditions	Minimum	Typical	Maximum	Units
Operation Frequency <sup>1</sup>		10		3000	MHz
Insertion Loss	1000 MHz		0.7	0.85	dB
	2000 MHz		0.9	1.05	dB
Isolation	1000 MHz	30	32		dB
	2000 MHz	21	23		dB
Return Loss	1000 MHz	18	22		dB
	2000 MHz	16	18		dB
'ON' Switching Time	50% CTRL to 0.1 dB of final value, 1 GHz		300		ns
'OFF' Switching Time	50% CTRL to 25 dB isolation, 1 GHz		200		ns
Video Feedthrough <sup>2</sup>			15		mV <sub>pp</sub>
Input 1 dB Compression	2000 MHz	26	27		dBm
Input IP3	2000 MHz, 14 dBm input power	43	45		dBm

Notes: 1. Device linearity will begin to degrade below 10 MHz

2. The DC transient at the output of any port of the switch when the control voltage is switched from Low to High or High to Low in a 50 Ω test set-up, measured with 1ns risetime pulses and 500 MHz bandwidth.

Figure 3. Pin Configuration (Top View)

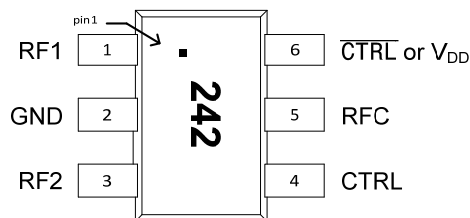

Table 2. Pin Descriptions<sup>1</sup>

Pin No.	Pin Name	Description
1	RF1	RF1 port <sup>2</sup>
2	GND	Ground connection. Traces should be physically short and connected to ground plane for best performance.
3	RF2	RF2 port <sup>1</sup>
4	CTRL	Switch control input, CMOS logic level
5	RFC	Common RF port for switch <sup>1</sup>
6	CTRL or V <sub>DD</sub>	This pin supports two interface options: <i>Single-pin control mode</i> . A nominal 3-volt supply connection is required. <i>Complementary-pin control mode</i> . A complementary CMOS control signal to CTRL is supplied to this pin. Bypassing on this pin is not required in this mode.

Note: 1. Operation should be restricted to the limits in the Operating Ranges table.  
2. All RF pins must be DC blocked with an external series capacitor or held at 0 V<sub>DC</sub>.

Table 3. Absolute Maximum Ratings

Symbol	Parameter/Conditions	Min	Max	Units
V <sub>DD</sub>	Power supply voltage	-0.3	4.0	V
V <sub>I</sub>	Voltage on any input	-0.3	V <sub>DD</sub> + 0.3	V
T <sub>ST</sub>	Storage temperature range	-65	150	°C
T <sub>OP</sub>	Operating temperature range	-40	85	°C
P <sub>IN</sub>	Input power (50 Ω)		30	dBm
V <sub>ESD</sub> <sup>1</sup>	HBM ESD Voltage		1500	V

Note: 1. Human Body Model ESD Voltage (HBM, MIL\_STD 883 Method 3015.7)

Exceeding absolute maximum ratings may cause permanent damage. Operation between operating range maximum and absolute maximum for extended periods may reduce reliability.

Table 4. DC Electrical Specifications

Parameter	Min	Typ	Max	Units
V <sub>DD</sub> Power Supply Voltage	2.7	3.0	3.3	V
I <sub>DD</sub> Power Supply Current (V <sub>DD</sub> = 3 V, V <sub>CTRL</sub> = 3 V)		250	500	nA
Control Voltage High	0.7x V <sub>DD</sub>			V
Control Voltage Low			0.3x V <sub>DD</sub>	V

### Electrostatic Discharge (ESD) Precautions

When handling this UltraCMOS™ device, observe the same precautions that you would use with other ESD-sensitive devices. Although this device contains circuitry to protect it from damage due to ESD, precautions should be taken to avoid exceeding the specified rating.

### Latch-Up Avoidance

Unlike conventional CMOS devices, UltraCMOS™ devices are immune to latch-up.

### Moisture Sensitivity Level

The Moisture Sensitivity Level rating for the PE4242 in the 6-lead SC-70 package is MSL1.

**Table 5. Single-pin Control Logic Truth Table**

Control Voltages	Signal Path
Pin 6 ( $V_{DD}$ ) = $V_{DD}$ Pin 4 (CTRL) = Low	RFC to RF1
Pin 6 ( $V_{DD}$ ) = $V_{DD}$ Pin 4 (CTRL) = High	RFC to RF2

**Table 6. Complementary-pin Control Logic Truth Table**

Control Voltages	Signal Path
Pin 6 ( $\overline{CTRL}$ or $V_{DD}$ ) = High Pin 4 (CTRL) = Low	RFC to RF1
Pin 6 ( $\overline{CTRL}$ or $V_{DD}$ ) = Low Pin 4 (CTRL) = High	RFC to RF2

### Control Logic Input

The PE4242 is a versatile RF CMOS switch that supports two operating control modes; single-pin control mode and complementary-pin control mode.

*Single-pin control mode* enables the switch to operate with a single control pin (pin 4) supporting a +3-volt CMOS logic input, and requires a dedicated +3-volt power supply connection on pin 6 ( $V_{DD}$ ). This mode of operation reduces the number of control lines required and simplifies the switch control interface typically derived from a CMOS  $\mu$ Processor I/O port.

*Complementary-pin control mode* allows the switch to operate using complementary control pins CTRL and  $\overline{CTRL}$  (pins 4 & 6), that can be directly driven by +3-volt CMOS logic or a suitable  $\mu$ Processor I/O port. This enables the PE4242 to be used as a potential alternate source for SPDT RF switch products used in positive control voltage mode and operating within the PE4242 operating limits.

Not for new designs

### Evaluation Kit

The SPDT Switch Evaluation Kit board was designed to ease customer evaluation of the PE4242 SPDT switch. The RF common port is connected through a 50  $\Omega$  transmission line to the top left SMA connector, J1. Port 1 and Port 2 are connected through 50  $\Omega$  transmission lines to the top two SMA connectors on the right side of the board, J3 and J2, respectively. A through transmission line connects SMA connectors J4 and J5. This transmission line can be used to estimate the loss of the PCB over the environmental conditions being evaluated.

The board is constructed of a two metal layer FR4 material with a total thickness of 0.031". The bottom layer provides ground for the RF transmission lines. The transmission lines were designed using a coplanar waveguide with ground plane model using a trace width of 0.0476", trace gaps of 0.030", dielectric thickness of 0.028", metal thickness of 0.0021" and  $\epsilon_r$  of 4.4.

J6 provides a means for controlling DC and digital inputs to the device. Starting from the lower left pin, the second pin to the right (J6-3) is connected to the device V1 or CTRL input. The fourth pin to the right (J6-7) is connected to the device V2 or CTRL/V<sub>DD</sub> input.

**Figure 4. Evaluation Board Layout**

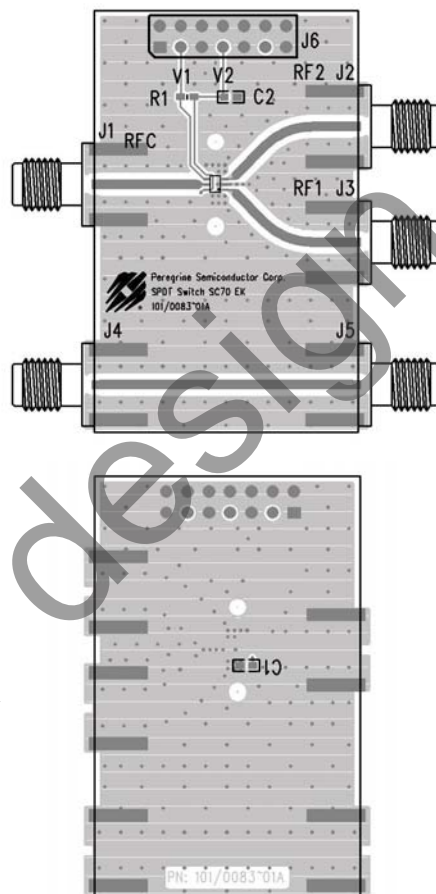

101/0083

**Figure 5. Evaluation Board Schematic**

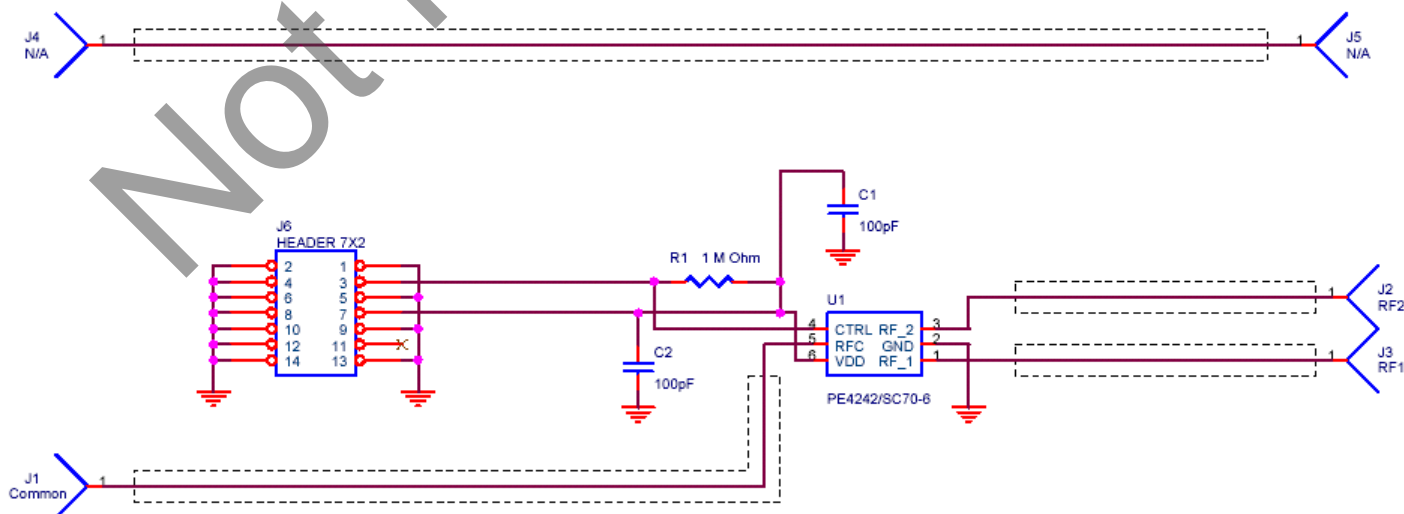

102/0145

Typical Performance Data @ -40 °C to 85 °C (Unless otherwise noted)

Figure 6. Insertion Loss – RFC to RF1

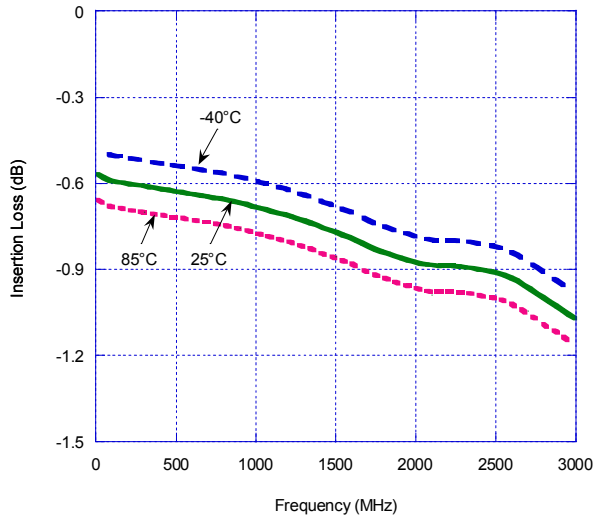

Figure 7. Input 1 dB Compression Point & IIP3  
(Typical Performance @ 25 °C)

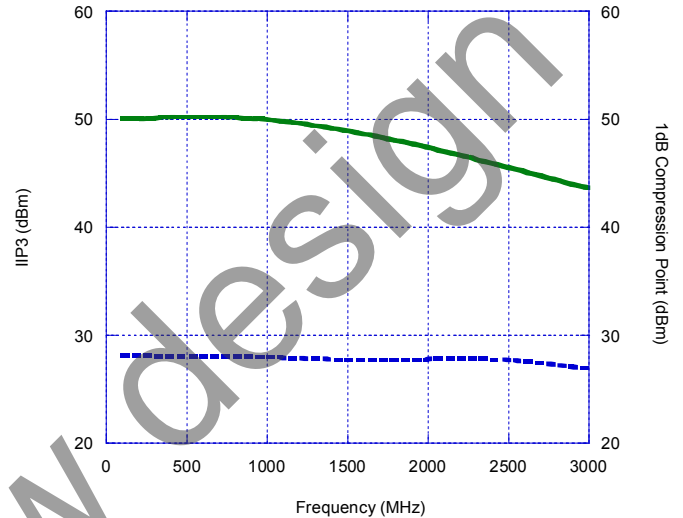

Figure 8. Insertion Loss – RFC to RF2

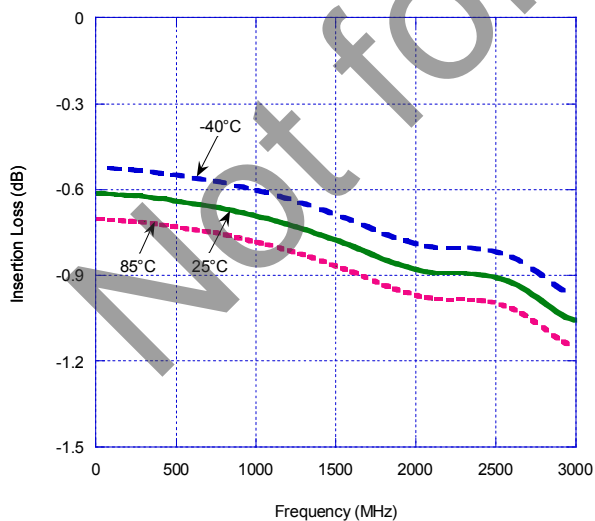
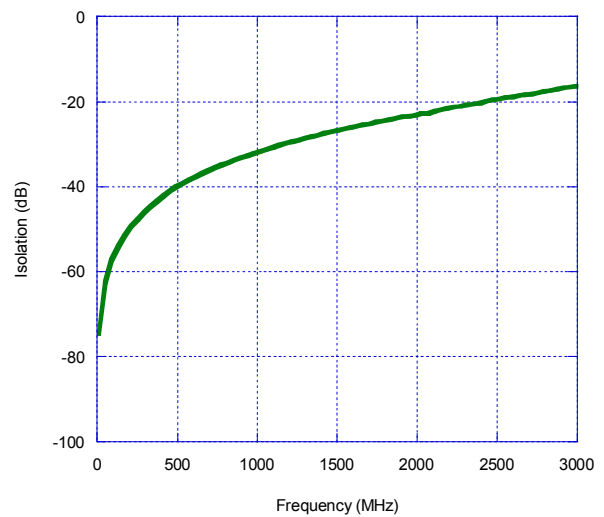
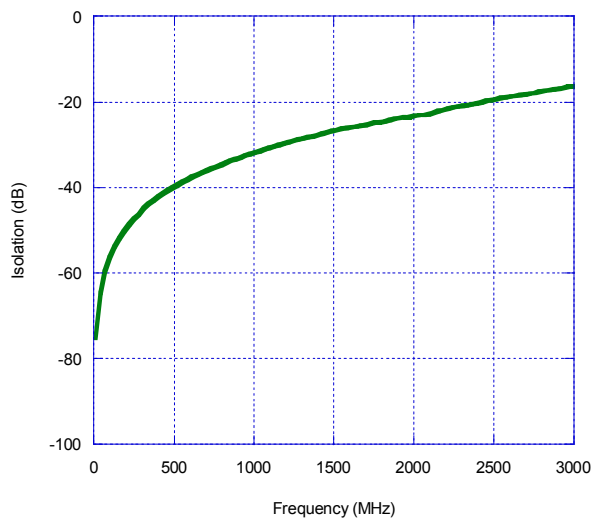

Figure 9. Isolation – RFC to RF1  
(Typical Performance @ 25 °C)



**Typical Performance Data @ 25°C**

**Figure 10. Isolation – RFC to RF2**



**Figure 11. Isolation – RF1 to RF2, RF2 to RF1**

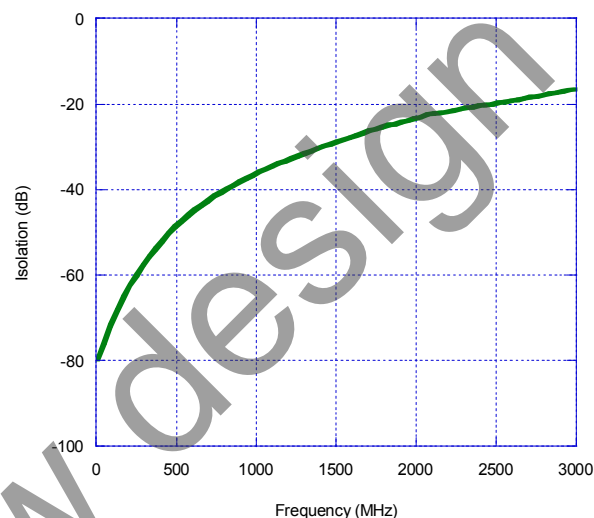

**Figure 12. Return Loss – RFC to RF1, RF2**

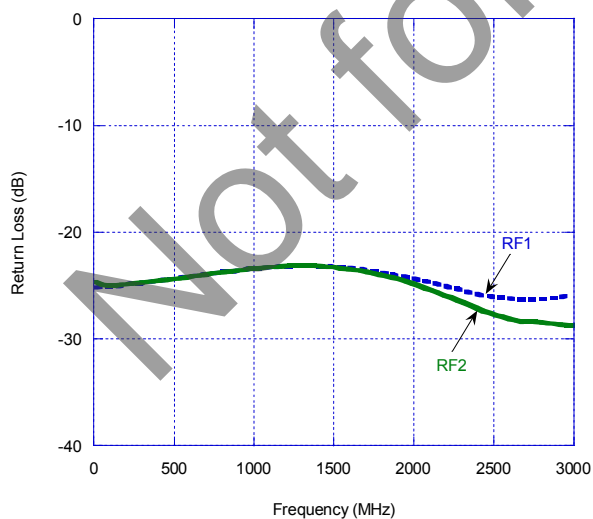

**Figure 13. Return Loss – RF1, RF2**

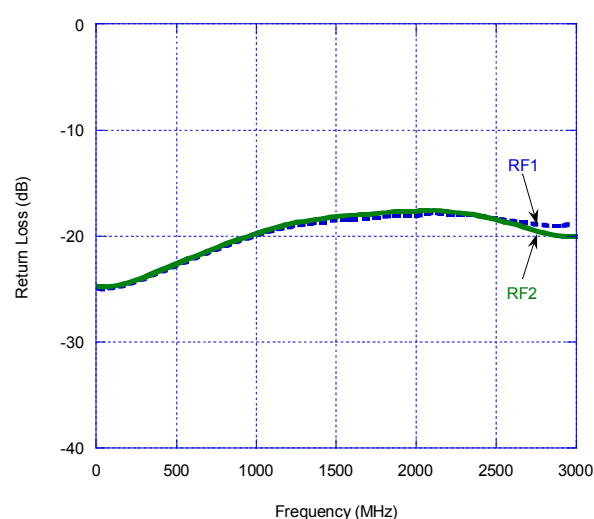
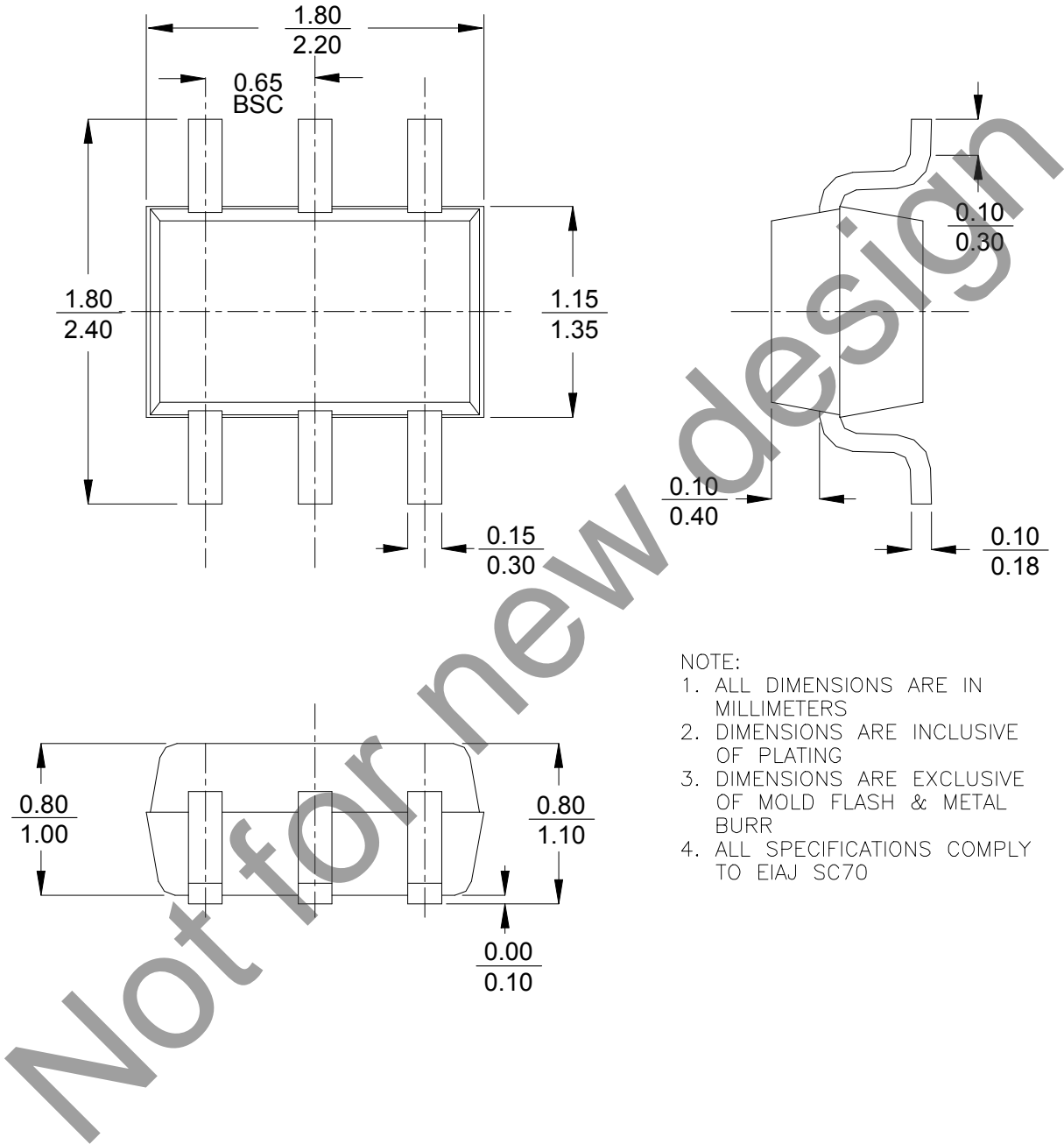
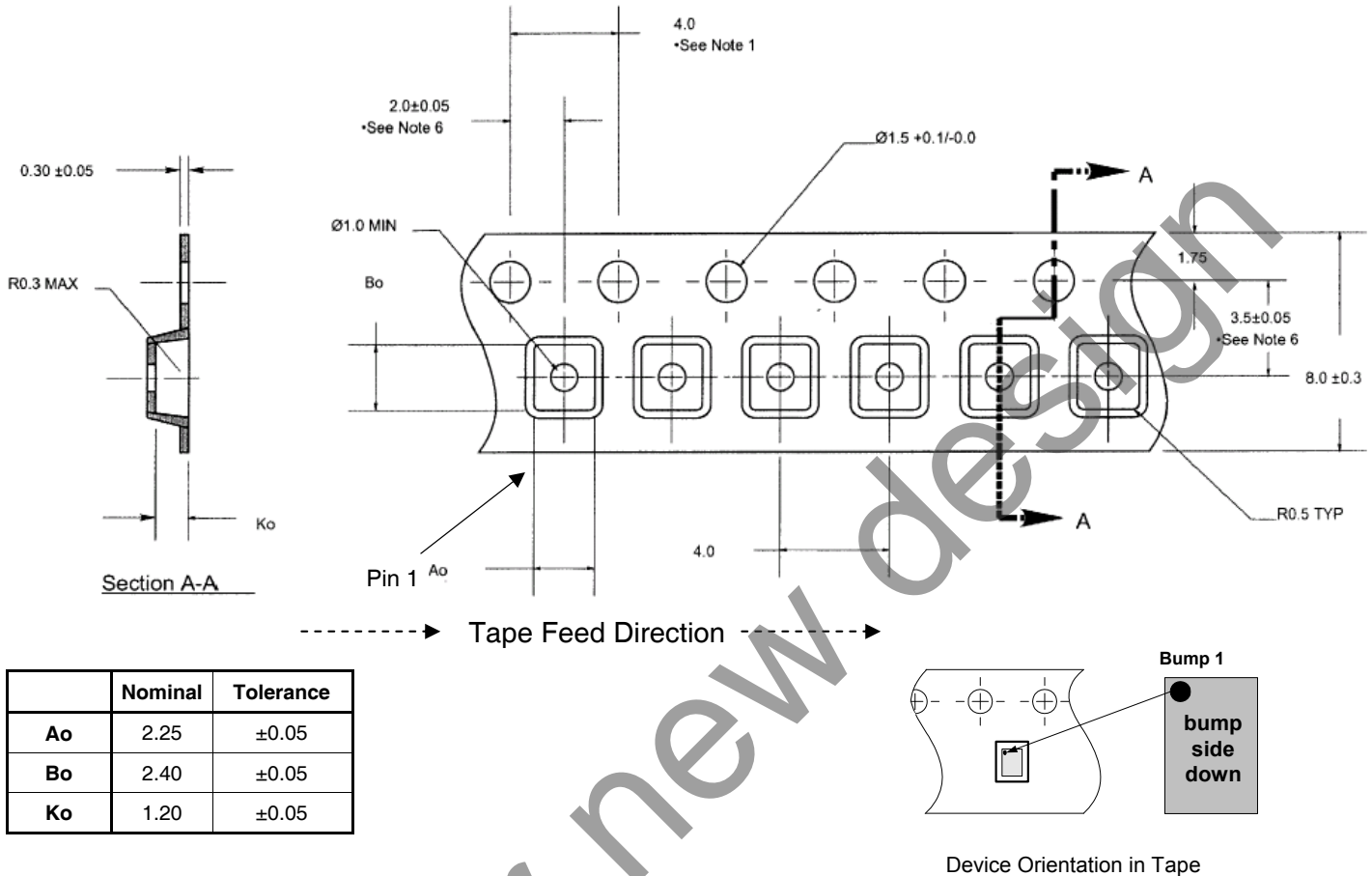

Figure 14. Package Drawing

6-lead SC-70



- NOTE:
1. ALL DIMENSIONS ARE IN MILLIMETERS
  2. DIMENSIONS ARE INCLUSIVE OF PLATING
  3. DIMENSIONS ARE EXCLUSIVE OF MOLD FLASH & METAL BURR
  4. ALL SPECIFICATIONS COMPLY TO EIAJ SC70

**Figure 15. Tape and Reel Specifications**

	Nominal	Tolerance
<b>Ao</b>	2.25	±0.05
<b>Bo</b>	2.40	±0.05
<b>Ko</b>	1.20	±0.05

Notes: 10 sprocket hole pitch cumulative tolerance  $\pm 0.02$   
 Camber not to exceed 1 mm in 100 mm  
 Material: Black Conductive Advantek Polystyrene  
 Ao and Bo measured on a plane 0.3 mm above the bottom of the pocket  
 Ko measured from a plane on the inside bottom of the pocket to the top surface of the carrier  
 Pocket position relative to sprocket hole measured as true position of pocket, not pocket hole

**Table 7. Ordering Information**

Order Code	Part Marking	Description	Package	Shipping Method
4242-00	PE4242-EK	PE4242-06SC70-EK	Evaluation Kit	1 / Box
4242-52	242	PE4242G-06SC70-3000C	Green 6-lead SC-70	3000 units / T&R

## Sales Contact and Information

For Sales and contact information please visit [www.psemi.com](http://www.psemi.com).

**Advance Information:** The product is in a formative or design stage. The datasheet contains design target specifications for product development. Specifications and features may change in any manner without notice.  
**Preliminary Specification:** The datasheet contains preliminary data. Additional data may be added at a later date. Peregrine reserves the right to change specifications at any time without notice in order to supply the best possible product.  
**Product Specification:** The datasheet contains final data. In the event Peregrine decides to change the specifications, Peregrine will notify customers of the intended changes by issuing a CNF (Customer Notification Form).  
 The information in this datasheet is believed to be reliable. However, Peregrine assumes no liability for the use of this information. Use shall be entirely at the user's own risk.

No patent rights or licenses to any circuits described in this datasheet are implied or granted to any third party. Peregrine's products are not designed or intended for use in devices or systems intended for surgical implant, or in other applications intended to support or sustain life, or in any application in which the failure of the Peregrine product could create a situation in which personal injury or death might occur. Peregrine assumes no liability for damages, including consequential or incidental damages, arising out of the use of its products in such applications.  
 The Peregrine name, logo, and UTSi are registered trademarks and UltraCMOS, HaRP, MultiSwitch and DuNE are trademarks of Peregrine Semiconductor Corp.