

Telegesis		TG-ETRX2-PM-001-109
ETRX2, ETRX2HR		Product Manual 1.09

ETRX2 and ETRX2HR ZIGBEE® MODULES

PRODUCT MANUAL



Table of Contents

1	INTRODUCTION.....	5
1.1	Hardware Description	5
1.2	Hardware precautions.....	5
1.2.1	Unexpected start-up in bootloader mode.....	5
2	PRODUCT APPROVALS.....	6
2.1	ETRX2 only.....	6
2.1.1	FCC Approvals.....	6
2.1.2	FCC Labelling Requirements.....	6
2.1.3	European Certification	6
2.2	ETRX2HR only.....	7
2.3	Declarations of Conformity.....	7
2.4	IEEE 802.15.4.....	7
2.5	The ZigBee® Protocol	7
3	MODULE PINOUT	9
4	HARDWARE DESCRIPTION	11
4.1	Hardware Options	11
4.1.1	On-board DC Regulator	11
4.1.2	On-board Reference Crystal.....	11
4.1.3	RF output pad	11
5	HARDWARE INTERFACE	12
6	FIRMWARE DESCRIPTION.....	13
6.1.1	Custom Firmware.....	13
6.2	Software Interface.....	14
7	ABSOLUTE MAXIMUM RATINGS.....	14
8	OPERATING CONDITIONS	15
9	DC ELECTRICAL CHARACTERISTICS.....	16
10	A/D CONVERTER CHARACTERISTICS	17
11	AC ELECTRICAL CHARACTERISTICS.....	17
12	PHYSICAL DIMENSIONS	19
13	SOLDERING TEMPERATURE TIME PROFILE (FOR REFLOW SOLDERING)	20
13.1	For Lead Solder	20
13.2	For Lead-free Solder.....	20
14	PRODUCT LABEL DRAWING.....	21
15	RECOMMENDED FOOTPRINT	22
15.1	Example carrier board.....	23

16	RELIABILITY TESTS	24
17	APPLICATION NOTES	24
17.1	Safety Precautions	24
17.2	Design Engineering Notes	24
17.3	Storage Conditions	25
18	PACKAGING	26
18.1	Embossed Tape	26
18.2	Component Orientation	27
18.3	Reel Dimensions	27
18.4	Packaging	27
19	ORDERING INFORMATION	28
20	TRADEMARKS	29
21	DISCLAIMER	29
22	ROHS DECLARATION	29
23	DATA SHEET STATUS	29
24	LIFE SUPPORT POLICY	29
25	RELATED DOCUMENTS	30
26	CONTACT INFORMATION	30

ETRX2 Summary

Image not shown actual size; enlarged to show detail.

Module Features

- Small form factor, SMT module 37.5 x 20.5 x 3.2 mm
- Optional board-to-board or board-to-cable connector
- 3 RF output options: Integrated ceramic antenna, Hirose U.FL coaxial connector or single port 50Ω pad
- XAP2b microcontroller with non intrusive debug interface (SIF)
- 128k flash and 5kbytes of SRAM
- UART interface with DMA, hardware I²C and SPI accessible with custom firmware
- Wide supply voltage range (2.1 to 3.6V)
- Module ships with standard Telegesis AT-style software interface based on the EmberNet meshing stack.
- Can act as ZigBee End Device, Router or Coordinator
- 12 general-purpose I/O lines and 2 analogue inputs (all 17 GPIOs of the EM250 are accessible)
- Supports 4 different power modes for extended battery life
- Current consumption below 1μA in deep sleep mode with self wakeup
- Firmware upgrades via RS232 or over the air (password protected)
- Hardware supported encryption (AES-128)
- Tested for CE and FCC compliance (with integrated antenna), FCC modular approval
- Operating temperature range: -40°C to +85°C
- Options include: On board low power voltage regulator, DC/DC regulator and watch crystal

Radio Features

- Based on the Ember EM250 single chip ZigBee®/IEEE802.15.4 solution
- 2.4GHz ISM Band
- 250kbit/s over the air data rate – NB: actual usable data throughput with ZigBee is about 20kbps
- 16 channels (802.15.4 Channel 11 to 26)
- +3dBm output power (+5dBm in boost mode)
- High sensitivity of -98dBm typ. at 1% packet error rate
- Hardware acceleration for IEEE 802.15.4 compliant transmissions

The Telegesis ETRX2 module is a low power 2.4GHz ISM band transceiver based on the Ember EM250 single chip ZigBee®/IEEE802.15.4 solution. It has been designed to be integrated into any device without the need for RF experience and expertise. Utilizing the EmberZNet meshing and self-healing stack, the ETRX2 enables you to add powerful wireless networking capability to your products and quickly bring them to market. The module's unique AT-style command line interface allows you to quickly integrate meshing radio technology without complex software engineering.

Suggested Applications

- AMR – Automatic Meter Reading
- Wireless Alarms and Security
- Home/Building Automation
- Wireless Sensor Networks
- M2M Industrial Controls
- Future ZigBee® systems
- PC Peripherals
- IEEE 802.15.4 Systems
- Item Tracking

Development Kits

- Two complementary development kits consisting of two or three modules and a single development board with USB connectivity and I/O breakouts.
- AT-style software interface command dictionary can be modified for high volume customers.
- Custom software development available upon request.

Example AT-Style Commands

AT+BCAST	Sends a Broadcast
AT+UCAST:<address>	Sends a Unicast
AT+EN	Establish PAN network
AT+JN	Join PAN

At power-up the last configuration is loaded from non volatile S-Registers, which can eliminate the need for an additional host controller.

1 Introduction

This document describes the Telegesis ETRX2 ZigBee® module which has been designed to be integrated into another device and to provide a fast, simple and low cost wireless mesh networking interface. Unless clearly indicated, its contents also apply to the ETRX2HR module with a Hirose U.FL coaxial antenna connector in place of the on-board ceramic antenna. The user cannot convert an ETRX2 into an ETRX2HR or vice-versa.

The Telegesis ETRX2 module has been designed to be built into any device and provide a low cost, low power, wireless mesh networking solution, using the Ember ZigBee® platform consisting of the single chip EM250 combined with their meshing stack. Integration into a wide range of applications is made easy using a simple AT style command interface and advanced hardware design.

The configurable functionality often allows the ETRX2 wireless meshing module to be used without an additional host microcontroller saving even more integration time and costs.

No RF experience or expertise is required to add this powerful wireless networking capability to your products. The ETRX2 offers fast integration opportunities and the shortest possible time to market for your product.

1.1 Hardware Description

The ETRX2 contains the single chip EM250 [2] from Ember Corp., a 24MHz reference crystal and RF front-end circuitry optimized for best RF performance. The module is available with an integrated antenna, U.FL male socket [3] or a 50 ohms pad terminal on the bottom of the module for RF output.

The integrated antenna is a Johanson 2450AT43A100, and details of the radiation pattern etc are available from their website [4].

The ETRX2 is used for ZigBee® (www.zigbee.org) applications. If you wish to create your own custom firmware, and not use the pre-loaded Telegesis AT-Command interface, you will need the InSight toolchain, consisting of InSight Desktop™ together with a comprehensive integrated development environment (IDE) and C-language compiler toolchain from Ember. The Ember firmware is not suitable for an 802.15.4-only application that does not use the ZigBee layer.

As an alternative to the Telegesis R2xx and R3xx series AT Command interfaces, the ETRX2 can also be supplied with Ember's UART EZSP (Ember ZigBee Serial Protocol) firmware. Please refer to the Ember EM260 manual for more information on the EZSP.

Important Note: In order to achieve the sleep currents shown in Section 9 you will need to add an external pull-down of 10kΩ to the MOSI pin. In some cases leaving this pin floating can increase the current consumption by about 10μA.

1.2 Hardware precautions

1.2.1 Unexpected start-up in bootloader mode

The bootloader which runs on the ETRX2 can be initiated with a firmware command, but it can also be triggered in hardware. If the A/D2 input (pad 10) is pulled low during the boot-up of the module it will enter the bootloader routine, so exercise caution when doing hardware design and ensure that this pin is not grounded during start-up and reset or driven from an analogue voltage that may be sensed as a logic 0. If unused the pad can be left floating and a pull-up is not required.

2 Product Approvals

The ETRX2 and ETRX2HR have been designed to meet all national regulations for world-wide use. In particular the following certifications have been obtained:

2.1 ETRX2 only

2.1.1 FCC Approvals

Using the integrated antenna it conforms to FCC CFR 47 Part 15 (USA).

This device complies with Part 15 of the FCC rules. Operation is subject to the following two conditions: (1) this device may not cause harmful interference, and (2) this device must accept any interference received, including interference that may cause undesired operation.



FCC ID: T7VEM250A

The ETRX2 device carries FCC authorization and is marked with the FCC ID Number. Whilst any device into which this authorized module is installed will not normally be required to obtain FCC authorization, this does not preclude the possibility that some other form of authorization or testing may be required for the finished device.

This module complies with the USA SAR requirements and is not intended to be operated within 20cm of the body. The following statement must be included as a CAUTION statement in manuals for OEM products to alert users on FCC RF exposure compliance:

“WARNING: To satisfy FCC RF exposure requirements for mobile transmitting devices, a separation distance of 20cm or more should be maintained between the antenna of this device and persons during operation. To ensure compliance, operations at closer distances than this are not recommended.”

If you require to use a specific external antenna with the ETRX2 module feel free to contact Telegesis about getting your choice of antenna tested to be included in the FCC approvals.

2.1.2 FCC Labelling Requirements

When the ETRX2 module is integrated inside another device/product, then the outside surface of that device/product must display a label referring to the enclosed module. This exterior label can use wording such as “**Contains Transmitter Module FCC ID: T7VEM250A**” or “**Contains FCC ID: T7VEM250A**” although any similar wording that expresses the same meaning may be used.

2.1.3 European Certification

With the integrated antenna the ETRX2 has been tested and conforms to the following standards:

- Radio: ETSI EN300 440-2 V1.1.1(2001-09)
- Radio: ETSI EN300 328 V1.6.1(11/2004)
- EMC: ETSI EN301 489-17 V1.2.1 (08/2002)
- Safety: ETSI EN60950-1:2001+A11:2004

CE0681 EC-R&TTE Certificated

If the ETRX2 module is incorporated into an OEM product, the OEM product manufacturer must ensure compliance of the final product to the European Harmonised EMC, and low voltage/safety standards. A Declaration of Conformity must be issued for each of these standards and kept on file as described in the R&TTE Directive. The final product must not exceed the specified power ratings, antenna specifications and installation requirements as specified in this ETRX2 user manual. If any of these specifications are exceeded in the final product then a submission must be made to a notified body for compliance testing to all of the required standards.

The 'CE' marking must be applied to a visible location on any OEM product. For more information please refer to <http://ec.europa.eu/enterprise/faq/ce-mark.htm>. Customers assume full responsibility for learning and meeting the required guidelines for each country in their distribution market.

2.2 ETRX2HR only

The ETRX2HR module has not been submitted for FCC or CE with an external antenna.

2.3 Declarations of Conformity

Telegesis (UK) Ltd has issued Declarations of Conformity for the ETRX2 ZigBee® RF Modules, which cover Radio Emissions, EMC and Safety. These DOC's are available from our website or on request

2.4 IEEE 802.15.4

IEEE 802.15.4 is a standard for low data rate, wireless networks (typical over the air data rates of 250 kbps @2.4GHz) which focuses on low cost, low duty cycle, long primary battery life applications as well as mains-powered applications. It is the basis for the open ZigBee® Protocol.

2.5 The ZigBee® Protocol

The ZigBee® Protocol is a set of standards for wireless connectivity for use between any devices over short to medium distances. The specification was originally ratified in December 2004, paving the way for companies to start making low-power networks a reality.

ZigBee® uses an IEEE 802.15.4 radio specification running on the 2.4GHz band, plus three additional layers for networking, security and applications. What makes the specification unique is its use of a mesh network architecture which, in bucket chain style, passes data from one node to the next until it lands at its destination. The network is self-healing and adapts its routing as link quality changes or nodes move. Furthermore, nodes can be defined as End Devices which do not act as routers, but can therefore be put into a low-power sleep state.

The enhanced version of the ZigBee® standard (or ZigBee® 2006) was released in December 2006, adding new features and improvements to the only global wireless communication standard enabling the development of easily deployable low-cost, low-power, monitoring and control products for homes, commercial buildings and industrial plant monitoring. In 2007 the ZigBee Alliance produced the very latest edition of the standard including the PRO featureset which offers advantages over earlier versions, including

- Truly self healing mesh networking

- Messages can now travel up to 30 hops
- Source-Routing for improved point to multipoint message transmission
- Improved security including Trust-Centre link keys
- New message types and options

Based on this latest standard, the Telegesis R3xx firmware for ZigBee PRO allows for

- Support for up to 4 external interrupts and 4 analogue inputs
- Nodes can be addressed by their EUI as well as their 16 bit NodeID
- Some level of interoperability with 3rd party ZigBee PRO compliant nodes

Please note that the R2xx and to some extent the R3xx Telegesis AT-Command line Interpreter are based on a private application profile and use the Ember meshing and self-healing stack, so interoperability with wireless mesh networking solutions from other manufacturers is unlikely when using this default firmware. For more information on ZigBee® compliance and the AT command interface please refer to the latest AT command dictionary and the ETRX2 user guide.

3 Module Pinout

The ETRX2 is pin compatible with the ETRX1, (NB: it has additional pins to the ETRX1). For all new designs using either ETRX1 or ETRX2 it is recommended that you use the ETRX2 footprint to ensure the option of future upgrading is guaranteed.



Figure 1: ETRX2 Module Pinout

The table below gives details about the 38 module pin signals for direct SMD soldering of the ETRX2 to the application board. The pin numbers shown in brackets () are the related pins of the EM250. In order to use the ETRX2 as a plug-in solution a Harwin 1.27mm pitch connector can be fitted on the bottom of the ETRX2 (Harwin part number M50-3601042). Other connectors that use the same footprint may also be used, such as a Samtec TFML-110-02-S-D.

All GND pads are connected within the module, but for best RF performance all of them should be grounded externally.

ETRX2 Pad	Function	EM250 GPIO	ETRX2 Harwin Pin
1	GND	GND	
2	Antenna		
3	GND	GND	
4	I/O9	GPIO 0 (21)	1
5	Vreg {1}		2
6	GND	GND	3
7	Vcc		10
8	GND	GND	3
9	A/D1	GPIO 4 (26)	4
10	A/D2	GPIO 5 (27)	5
11	I/O7	GPIO 3 (25)	6
12	I/O6	GPIO 2 (24)	7
13	I/O5	GPIO 1 (22)	8
14	I/O4 or RTS {3}	GPIO 12 (20)	9
15	GND	GND	
16	SIF CLK	SIF CLK	
17	SIF MISO	SIF MISO	
18	SIF MOSI	SIF MOSI	
19	SIF LOADB	SIF LOADB	
20	GND	GND	
21	I/O8	GPIO 6 (29)	11
22	I/O2 or CTS {3}	GPIO 11 (19)	12
23	I/O3	GPIO 13 (43)	13
24	Reset	(13)	14
25	I/O1	GPIO 14 (42)	15
26	I/O0	GPIO 8 (31)	16
27	TXD {2}	GPIO 9 (32)	18
28	RXD {2}	GPIO 10 (33)	17
29	GND	GND	3
30	I/O10	GPIO 15 (41)	19
31	I/O11	GPIO 16 (40)	20
32	GND	GND	
33	RXTXSW	(11)	
34	GND	GND	
35	GND	GND	
36	GND	GND	
37	GND	GND	
38	N/C {4}	GPIO 7 (30)	

Table 1: Pin Information
Notes:

{1} Where the onboard regulator option is mounted this pin is connected to the output voltage of the onboard regulator option and **NOT** to the output voltage VREG_OUT of the EM250

{2} TXD is the UART output, RXD is the input

{3} RTS/CTS handshaking is selectable in firmware. See the AT Command Manual.

{4} Pad 38 is connected to GPIO7 but is not used by the Telegesis firmware

4 Hardware Description

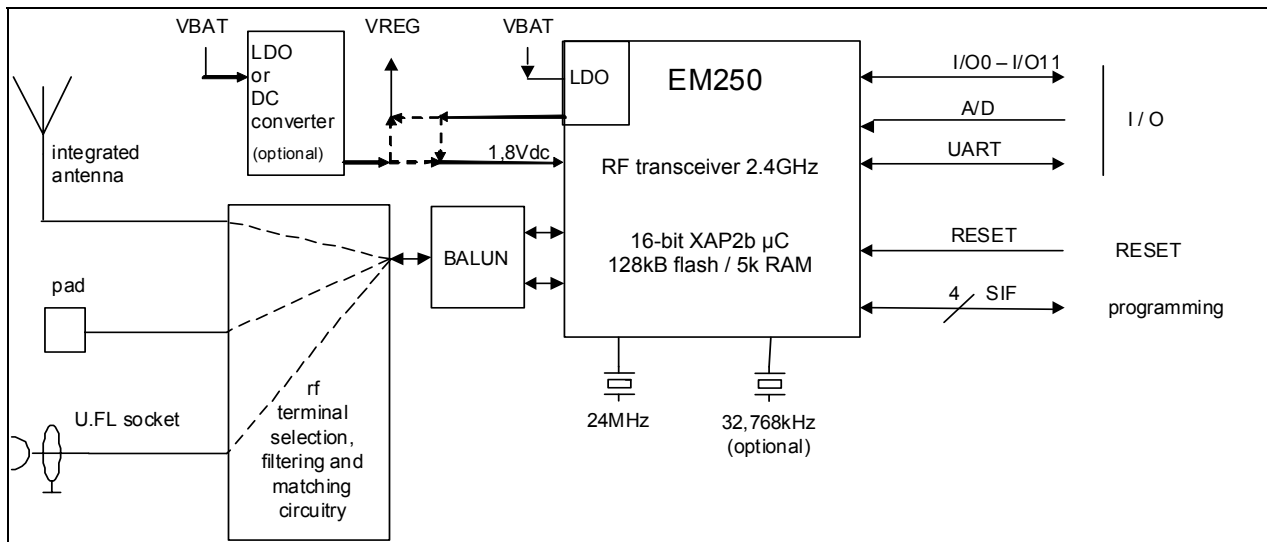

Figure 2: Hardware Diagram

4.1 Hardware Options

Please contact the manufacturer if any of the options described below could be useful in your product design. Please note that to include these options a high order quantity is required and they are not available as standard products.

4.1.1 On-board DC Regulator

Although the EM250 already contains an internal LDO regulator, the module can be supplied with an additional integrated onboard LDO regulator or DC/DC converter. Some applications could benefit from this additional regulator in instances where:

- (1) Further extension of the input voltage range is required
- (2) Extended battery life is obtained by replacing the regulator within the EM250 with a special ultra-low quiescent current regulator
- (3) Operation is required using very noisy power supplies

Two different types of regulators are available, a linear low dropout (LDO) type or a high efficiency switched buck regulator. Depending on the power supply conditions of the application the optimum regulator can be selected.

4.1.2 On-board Reference Crystal

A second option which is available is an on-board 32.768kHz crystal reference. This option can be provided for applications which require a high precision reference clock.

4.1.3 RF output pad

Thirdly, the RF output can be connected to pad 2 for routing on to the underlying circuit board. There is then no ceramic antenna nor U.FL connector.

5 Hardware Interface

All I/O pins of the EM250 are accessible on the module's pads. The pre-loaded Telegesis AT Command Interface defines those I/O's as described below. Please refer to the Command Dictionary or to the User Guide to learn more about the pre-loaded firmware. When developing custom firmware all pins can be utilised as described in the EM250 datasheet.

ADC

The module has up to four analogue inputs. Readings with reference to the internal 1.2V reference voltage can be made locally as well as over the air.

I/O

Pins I/O11 down to I/O0 are bi-directional I/O ports which can be controlled locally as well as remotely by accessing local as well as remote S-registers. The functionality of the I/Os can be controlled using three single 16-bit registers representing the data direction, the output buffer and the input buffer. With the R3xx series of firmware it is now also possible to select internal pull-ups or pull-downs for each individual I/O.

UART

The AT style command interpreter can be accessed via the TXD and RXD pins. The ETRX2 can buffer up to 128 bytes of incoming data in a software FIFO buffer and uses XON/XOFF or hardware flow control. See [2] for more information about the built-in UART.

Interrupt

Up to 4 I/Os can trigger user definable actions. User configurable edges can cause interrupts if this function is enabled in the S-Registers.

Reset

Pulling the reset pin low will cause the module to restart. An external pull-up is not required, but can be added for use in a very noisy environment.

PWM

I/O3 can alternatively act as a special function pin which can generate output waveforms up to 12MHz or act as a PWM. This functionality can be controlled locally as well as remotely by accessing local as well as remote S-registers.

Antenna

Matching is provided to match the radio to the integrated antenna or to an optional external general purpose 2.4GHz antenna. The on-board antenna is supplied by Johanson. For full data on the Johanson antenna please refer to [4]. The connector on the ETRX2HR is Hirose part number U.FL-SMT-R.

Power

The module is able to operate from 3.6V down to 2.1V which makes it ideally suited for battery-powered applications.

SIF

Interface for programming and real-time debugging the EM250. It is recommended to add a 10k Ω pull-down externally to the MOSI pin as this pin is otherwise floating during sleep modes increasing the current consumption by 10-15 μ A.

6 Firmware Description

The modules are pre-loaded with a standalone bootloader which supports over-the-air bootloading as well as serial bootloading of new firmware.

In order to enter the standalone bootloader using a hardware trigger pull A/D2 (GPIO5) to ground and power-cycle the module. To avoid entering the standalone bootloader unintentionally make sure not to pull this pin down during boot-up unless the resistance to ground is $>10k\Omega$. (A pull-up is not required).

In addition to the standalone bootloader the modules also contain the current release of the Telegesis AT-style command interface as described in the Telegesis AT command dictionary and the Telegesis user guide. Check www.telegesis.com for updates. Each module comes with a unique 64-bit 802.15.4 identifier which is stored in non-volatile memory. The commands and responses pass through the serial port of the ETRX2 as ASCII text, so a simple terminal application will usually suffice. We provide Telegesis Terminal but it is not an essential feature.

The pre-loaded AT-style command interface firmware is based on the latest EmberZNet meshing stack which implements routers/coordinators as well as (sleepy) end devices. [End devices have no routing responsibility and therefore are allowed to go to sleep, whilst still being able to send and receive messages via a parent router. In addition to a classical (sleepy) end device the module firmware also supports a mobile (sleepy) end device capable of changing its parent quickly whenever it changes its position within the network.]

A router is typically a mains powered device whilst a sleepy end device (SED) can be battery powered.

The module is also able to act as a PAN coordinator through external host control. The AT style command line supplies all the tools required to set up and manage a wireless mesh network by allowing easy access to the low-level functionality of the stack.

The ETRX2 firmware uses the meshing and self healing EmberZNet PRO stack to overcome many of the limitations of the tree network topology of the ZigBee® 2006 stack. Following further evolution of the ZigBee® mesh networking specification, Telegesis also offer firmware that implements the PRO feature set of ZigBee 2007.

The Telegesis firmware also allows low-level access to physical parameters such as channel and power level. Parameters that define the functionality of the ETRX2 module and also allow standalone functionality are saved in non-volatile memory organised in so-called S-Registers. The SPI and I2C buses are not supported by the current firmware release, but can be used with custom firmware.

As a third option as opposed to using the Telegesis AT command interface or developing custom firmware, the Ember EZSP UART interface can be provided to allow ZigBee® application development using a host controller driven binary protocol. For more information on the EZSP interface please refer to the Ember EM260 datasheet.

6.1.1 Custom Firmware

For high volume customers the firmware can be customised on request. Customers can use the ETRX2 module as hardware only and develop their own firmware based on the EmberZNet stack. In order to develop custom firmware Insight Desktop™ is required together with a comprehensive integrated development environment (IDE) and C-language compiler toolchain from Ember.

6.2 Software Interface

Using the default firmware the ETRX2 is controlled using a simple AT-style command interface and (mostly) non-volatile S-Registers. In order to get a full listing of all the available AT-Commands, please refer to the AT command dictionary document which corresponds to the firmware revision you intend to use.

In addition to the command dictionary there are user guides explaining the features of the firmware in more detail. If you need to find out which firmware resides on your module simply type “**ATI**” followed by a carriage return and you will be prompted with the module’s manufacturing information.

The Development Kit manual describes how to upgrade the firmware either via a serial link or over the air.

7 Absolute Maximum Ratings

Supply: 3.6V
Inputs: -0.3V to Vcc+0.3V
Operating temperature: -40 to 85°C

No.	Item	Symbol	Absolute Maximum Ratings	Unit
1	Supply voltage	V _{BAT}	-0.1 to +3.6	Vdc
2	Voltage on any I/O[11:0] , SIF_CLK, SIF_MISO, SIF_MOSI, SIF_LOADB, RESET, REG_OUT	V _{in}	-0.3 to V _{BAT} +0.3	Vdc
3	Voltage applied to Vreg	Vreg	-0.3 to 2.0	Vdc
4	Storage temperature range	T _{stg}	-40 to +105	°C
5	Operating temperature range	T _{op}	-40 to +85	°C
6	Input RF level	P _{max}	0	dBm
7	ESD on any pin ⁽¹⁾ according to Human Body Model (HBM) circuit description	V _{THHBM}	±2	kV
8	Reflow temperature	T _{Death}	T.B.D.	°C

Table 2: Absolute Maximum Ratings

Notes:

(1) Input must be current limited to the value specified.

The absolute maximum ratings given above should under no circumstances be violated. Exceeding one or more of the limiting values may cause permanent damage to the device.



Caution! ESD sensitive device. Precautions should be used when handling the device in order to prevent permanent damage.

8 Operating Conditions

No.	Item	Condition / Remark	Symbol	Value			Unit
				Min	Typ	Max	
1	Supply voltage	The typical value is recommended	V_{DD}	2.1	3.0	3.6	Vdc
2	RF Input Frequency		f_C	2405		2480	MHz
3	RF Input Power		P_{IN}			0	dBm
4	Maximum Tx output power	Tx normal mode	P_{OUT}		3		dBm
5	Logic Input Voltage Low		V_{IL}	0		0.2x VBAT	V
6	Logic Input Voltage High		V_{IH}	0.8x VBAT		VBAT	V
7	Voltage Level on any of the A/D Inputs		VA/D			1.2	V
8	SPI clock rate		f_{SPI}			12	MHz
9	Operating temperature range		T_{op}	-40		+85	°C

Table 3: Operating Conditions

The average current consumption during operation is dependent on the firmware and the network load, therefore these figures are given in the AT command dictionary of the respective firmware.

9 DC Electrical Characteristics

VBAT = 3.0V, T_{amb} = 25°C unless otherwise stated

No.	Item	Condition / Remark	Symbol	Value			Unit
				Min	Typ	Max	
1	Module supply voltage VBAT		V _{BAT}	2.1	3.0	3.6	Vdc
2	Internal regulated core voltage	connected to Vreg pad 5 ⁽¹⁾	V _{CORE}	1.7	1.8	1.9	Vdc
3	Quiescent current, including internal RC oscillator	10kΩ pull-down at SIF_MOSI pin	I _{SLEEP}			1.0	μA
4	Quiescent current, including 32.768kHz oscillator	10kΩ pull-down at SIF_MOSI pin	I _{SLEEP}			1.5	μA
5	Transmit current consumption	total at +3dBm maximum output power	I _{TX}		35.5		mA
6	Transmit current consumption	total at +5dBm maximum output power at boost mode	I _{TX}		41.5		mA
7	Transmit current consumption	total at -32dBm minimum output power	I _{TX}		28		mA
8	Receive current consumption	total	I _{RX}		35.5		mA
9	Receive current consumption	total (boost mode)	I _{RX}		37.5		mA
10	External load on internal regulated core voltage	connected to Vreg pad 5 ⁽¹⁾	I _{REG_OUT}			2	mA
11	Input voltage for logic 0		V _{IL}	0		0.2x VBAT	Vdc
12	input voltage for logic 1		V _{IH}	0.8x VBAT		VBAT	Vdc
13	Input current for logic 0		I _{IL}			-0.5	μA
14	input current for logic 1		I _{IH}			0.5	μA
15	input pull-up resistor value		R _{I_{PU}}		30		kΩ
16	input pull-down resistor value		R _{I_{PD}}		30		kΩ
17	Output voltage for logic 0		V _{OL}	0		0.18x VBAT	Vdc
18	Output voltage for logic 1		V _{OH}	0.82x VBAT		VBAT	Vdc
19	Output source current (standard current pad)		I _{OHS}			4	mA
20	Output sink current (standard current pad)		I _{OLS}			4	mA
21	Output source current (high current pad: I/O3, I/O1, I/O10, I/O11)		I _{OHH}			8	mA
22	Output sink current (high current pad: I/O3, I/O1, I/O10, I/O11)		I _{OLH}			8	mA
23	Total output current for I/O pads		I _{OH} + I _{OL}			40	mA

Table 4: DC Electrical Characteristics

Notes: For more information about the internal regulated core voltage refer to part 5.7 in [2]. As the internal regulated core voltage at Vreg mainly feeds circuitry on ETRX2, the Vreg module pin may only be slightly loaded and without feeding noise to Vreg. Vreg is not available in Power Mode 3 (see the AT Command Manual for details of power modes).

Where the dc regulator option is mounted Vreg is connected to the regulator option output instead and the internal regulated core voltage is not accessible.

10 A/D Converter Characteristics

No.	Item	
1	A/D characteristics	refer to datasheet EM250 part 5.5 ADC Module
2	A/D timing/performance characteristics	refer to datasheet EM250 part 5.5 ADC Module
3	Reference Voltage	1.2V
4	Maximum Input Voltage	1.2V

Table 5: A/D Converter Characteristics

Note: If a voltage higher than 1.2V is applied to any of the ADC inputs, the readings on the other ADCs will be incorrect.

11 AC Electrical Characteristics

V_{BAT} = 3.0V, T_{amb} = 25°C, measured at 50Ω terminal load ⁽²⁾

No.	Receiver	Value			Unit
		Min	Typ	Max	
1	Sensitivity for 1% Packet Error Rate (PER)	-94	-98	-	dBm
2	Sensitivity for 1% Packet Error Rate (PER) (boost mode)	-95	-99	-	dBm
3	Saturation (maximum input level for correct operation, low gain)	0	-	-	dBm
4	Adjacent Channel Rejection (1% PER and desired signal -82dBm acc. to [1])		35		dB
5	Alternate Channel Rejection (1% PER and desired signal -82dBm acc. to [1])		40		dB
6	Channel Rejection for all other channels (1% PER and desired signal -82dBm acc. to [1])		40		dB
7	802.11g rejection centred at +12MHz or -13MHz (1% PER and desired signal -82dBm acc. to [1])		40		dB
8	Co-channel rejection (1% PER and desired signal -82dBm acc. to [1])		-6		dBc
9	Relative frequency error (2x40ppm required by [1])	-120		120	ppm
10	Relative timing error (2x40ppm required by [1])	-120		120	ppm
11	Linear RSSI range	40			dB
12	Spurious Emissions <1GHz	-	TBD	-57	dBm
13	Spurious Emissions >1GHz	-	TBD	-47	dBm

No.	Transmitter	Limit			Unit
		Min	Typ	Max	
14	Output power at highest power setting normal mode	0	3		dBm
15	Output power at highest power setting boost mode		5		dBm
16	Output power at lowest power setting normal mode		-32		dBm
17	Error vector magnitude		15	35	%
18	Carrier frequency error	-40		40	ppm
19	PSD mask relative 3.5MHz distance from carrier	-20			dB
20	PSD mask absolute 3.5MHz distance from carrier	-30			dBm
21	2nd harmonic at highest power setting normal mode	-	-55	-30	dBm
22	3rd harmonic at highest power setting normal mode	-	-55	-30	dBm
23	2nd harmonic at highest power setting boost mode	-	-50	-30	dBm
24	3rd harmonic at highest power setting boost mode	-	-50	-30	dBm
25	Spurious Emissions <1GHz	-	< -54	-36	dBm
26	Spurious Emissions >1GHz	-	< -60	-30	dBm

Table 6: AC Electrical Characteristics

Notes:

(1) at pin 38 RF or U.FL socket, for all channels number 11,12,..., 26 according to ref [1]

No.	Standby	Limit			Unit
		Min	Typ	Max	
27	Spurious Emissions <1GHz	-	TBD	-57	dBm
28	Spurious Emissions >1GHz	-	TBD	-47	dBm

Table 7: Standby Spurious Emissions

No.	Synthesiser Characteristics	Limit			Unit
		Min	Typ	Max	
29	Lock time from off state, with correct VCO DAC settings			100	µs
30	Relock time, channel change or Rx/Tx turnaround			100	µs

Table 8: Synthesiser Characteristics

No.	Power On Reset (POR) Specifications	Limit			Unit
		Min	Typ	Max	
31	V _{BAT} POR release	1.0	1.2	1.4	Vdc
32	V _{BAT} POR assert	0.5	0.6	0.7	Vdc
33	V _{CORE} POR release	1.35	1.5	1.65	Vdc
34	V _{CORE} POR hysteresis	0.08	0.1	0.12	Vdc

Table 9: Power On Reset Specifications for EM250 chip

12 Physical Dimensions

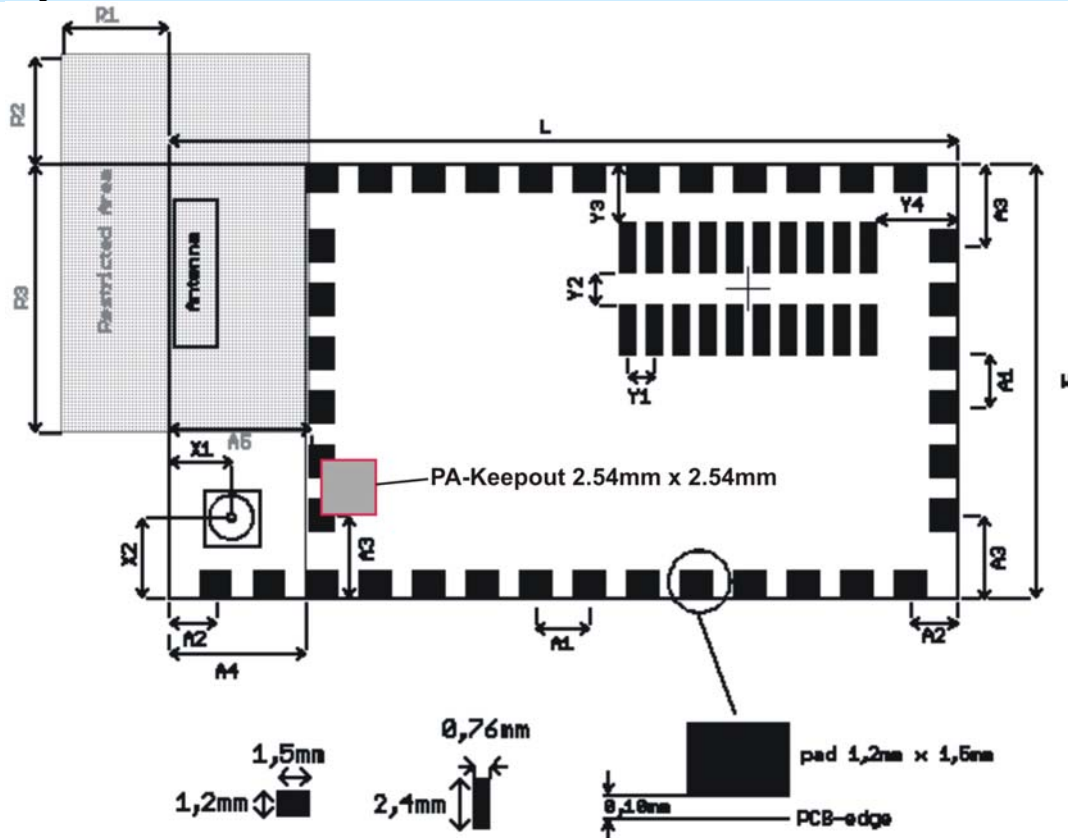

Figure 3: ETRX2 Physical Dimensions

Symbol	Explanation	Distance
L	Length of the module	37.5mm
W	Width of the module	20.5mm
H	Height of the module	3.20mm
A1	Pitch	2.54mm
A2	Distance centre of pad PCB edge	2.24mm
A3	Distance centre of pad PCB edge	3.9mm
A4	Distance PCB edge metal can	6.5mm
A5	Distance PCB edge start of pad	6.7mm
R1	Keep-out Zone from corner of PCB	5.0mm
R2	Keep-out Zone from corner of PCB	5.0mm
R3	Width of keep-out Zone adjacent to PCB	12.7mm
X1	Distance centre of Antenna connector PCB edge	3.00mm
X2	Distance centre of Antenna connector PCB edge	3.80mm
Y1	Pitch	1.27mm
Y2	Distance between rows of pads	1.50mm
Y3	Distance between edge of PCB and pad	2.75mm
Y4	Distance between edge of PCB and pad	3.8mm

Table 10: Physical Dimensions ETRX2

For ideal RF performance when using the on-board antenna, the antenna should be located at the corner of the carrier PCB. There should be no components, tracks or copper planes in the “keep-out” area which should be as large as possible; note also the small secondary keep-out area which is required for best performance using the -PA version. If using the U.FL RF connector the “keep-out” area can be significantly reduced. **NB:** The module transmit/receive range will depend strongly on the antenna used and also the housing of the finished product.

13 Soldering Temperature Time Profile (for reflow soldering)

13.1 For Lead Solder

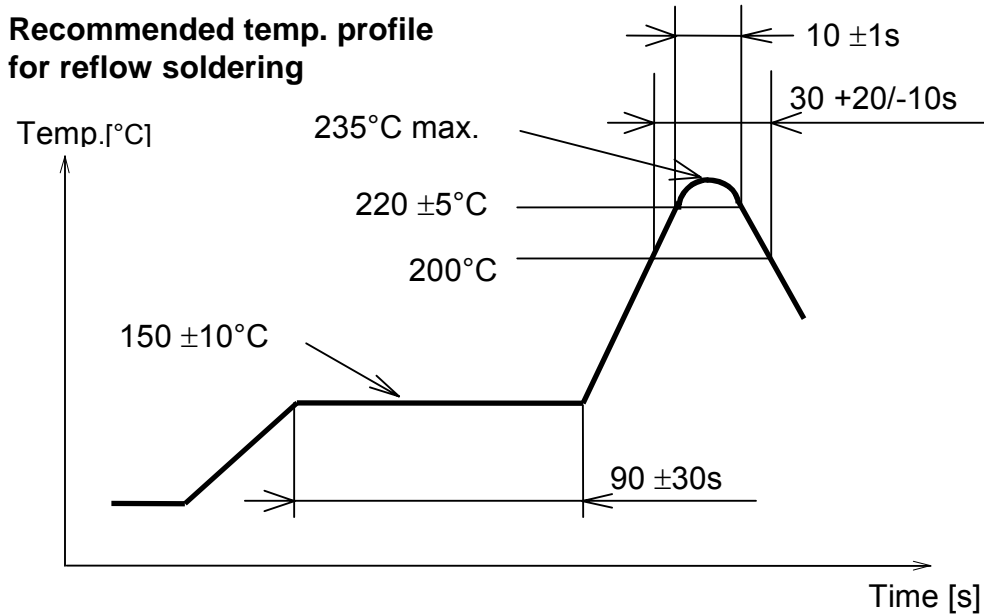

Figure 4: Temperature Profile for Lead Solder

13.2 For Lead-free Solder

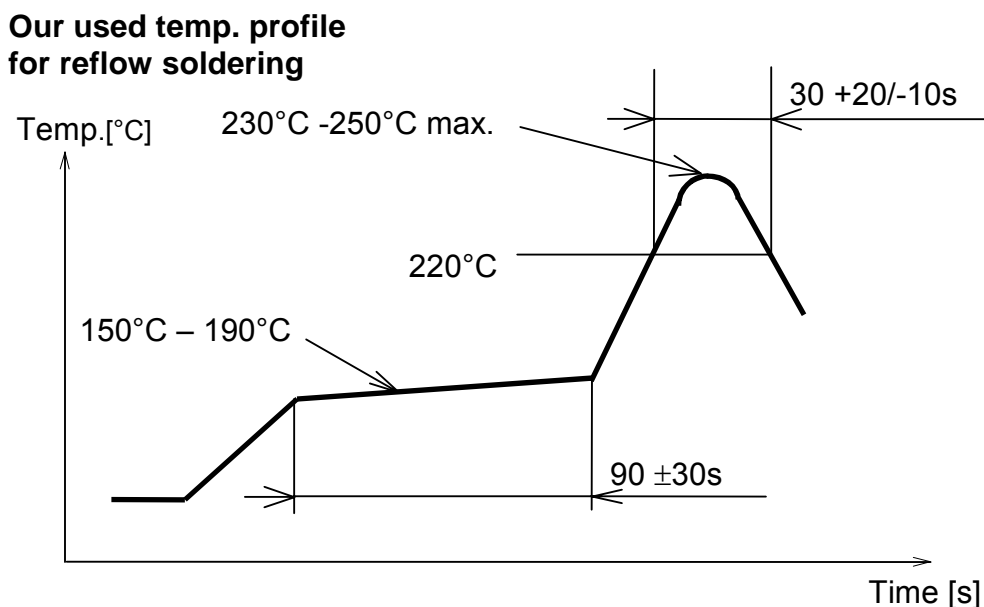

Figure 5: Temperature Profile for Lead-free Solder

NB:

Maximum Reflow Cycles: 2

Opposite-side reflow is prohibited due to the modules weight. (i.e. you must not place the module on the bottom / underside of your pcb and re-flow).

14 Product Label Drawing



Figure 6: Product Label

The label dimensions are is 13.0mm x 18.5 mm. The label is suitable for reflow soldering.

Imprint	Description
ETRX2	Module Name
0000001	Indication for the serial number.
Date Code	Production Date Code in the format YYMMDD, e.g. 060602
01	Indication for batch number
01Z	Indication for the hardware revision
FCC ID: T7VEM250A	FCC ID code for this product
2D-Barcode	Information in the 2D-Barcode are the serial number [7 signs], the Part-Number [11 signs], identifier for the batch number [2 signs], the identifier for the hardware release [2 signs] and the production date code in the format Year-Month-Day [6 signs], separated by a semicolon.

Table 11: ETRX2 Label Details

15 Recommended Footprint

In order to surface mount the module, we recommend that you use pads which are 1.5mm wide and 1.7mm high, the extra height extending the pads shown in Figure 3 towards the outside of your layout. You must retain the “keep-out” zone shown in Figure 3 (page 19), and ensure that this area is free of copper tracks and/or copper planes/layers.

You must also ensure that there are no exposed pads or vias on your layout which may contact with the pads (for the optional connector), or vias on the bottom surface of the ETRX2 module.

If the module is to be soldered by hand for prototyping we recommend that you increase the height of the pads to allow easier access.

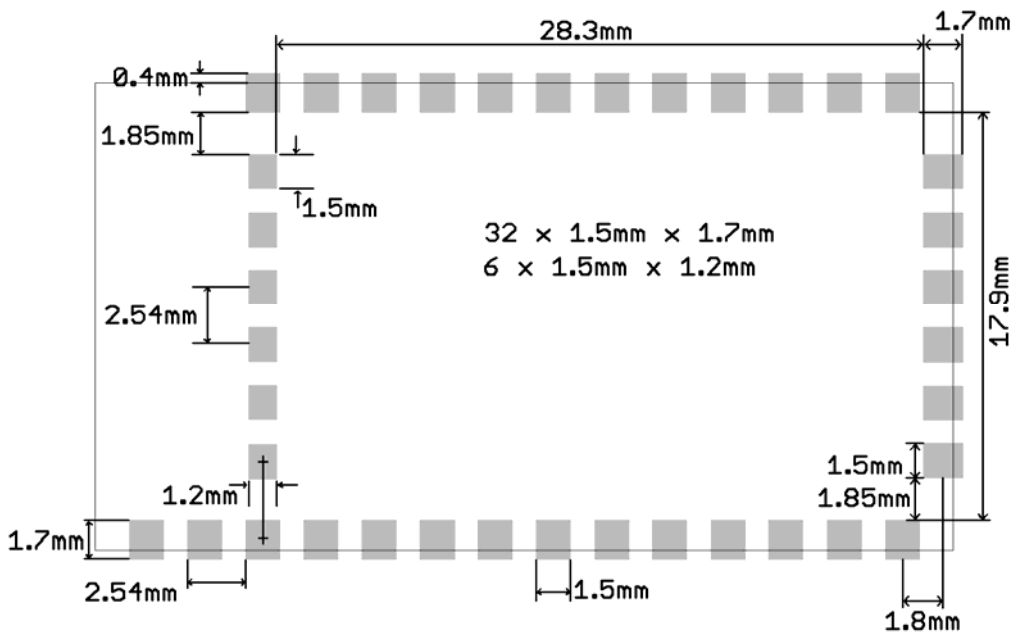

Figure 7. Recommended Footprint

The land pattern dimensions above serve as a guideline.

We recommend that you use the same pad dimensions for the solder paste screen as you have for the copper pads. However these sizes and shapes may need to be varied depending on your soldering processes and your individual production standards. We recommend a paste screen thickness of 120µm to 150µm, although it may be necessary to go up to 200µm to ensure reliable joints.

Although the under side of ETRX2 is fully coated (except for the footprint of the additional Harwin SMT connector), no exposed copper, such as through-hole vias, planes or tracks on your board component layer, should be located below the ETRX2 in order to avoid ‘shorts’. In cases where a exposed track or through hole via has to be located under the module it must be kept away from ETRX2 via holes. The ETRX2 multilayer PCB contains an inner RF shielding ground plane, therefore there is no need to have an additional copper plane directly under ETRX2.

15.1 Example carrier board

Since the RF performance of the module with the on board antenna is strongly dependent on the proper location of the module on its carrier board Figure 8 shows the reference carrier board, which was used during testing by Telegesis.

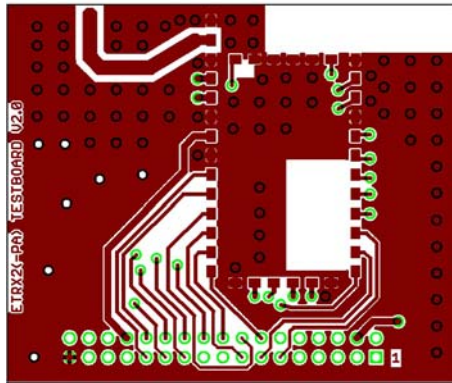

Figure 8. Reference Board

For best performance it is recommended to locate the antenna towards the corner of the carrier board and to respect the recommended keepout areas as described in section 12.

Finally to provide a good reference ground to the on board antenna, the carrier board should have a ground plane spanning no less than 60 x 50mm. In many cases a smaller ground plane will suffice, but a degradation in radio performance could be the result.

16 Reliability Tests

The measurements were conducted after the module being exposed to room temperature and humidity for 1 hour.

No	Item	Limit	Condition
1	Vibration test	Electrical parameter should be in specification	a) Freq.:10~50Hz,Amplitude:1.5mm a) 20min. / cycle,1hrs. each of XYZ axis b) Freq.:30~100Hz, 6G b) 20min. / cycle,1hrs. each of XYZ axis
2	Shock test	the same as the above	Dropped onto hard wood from height of 50cm for 3 times
3	Heat cycle test	the same as the above	-40°C for 30min. and +85°C for 30min.; each temperature 300 cycles
4	Moisture test	the same as the above	+60°C, 90% RH, 300h
5	Low temp. test	the same as the above	-40°C, 300h
6	High temp. test	the same as the above	+85°C, 300h

Table 12: Reliability Tests

17 Application Notes

17.1 Safety Precautions

These specifications are intended to preserve the quality assurance of products as individual components.

Before use, check and evaluate their operation when mounted on your products. Abide by these specifications, without deviation when using the products. These products may short-circuit. If electrical shocks, smoke, fire, and/or accidents involving human life are anticipated when a short circuit occurs, then at least, provide the following failsafe functions, as a minimum:

- (1) Ensure the safety of the whole system by installing a protection circuit and a protection device.
- (2) Ensure the safety of the whole system by installing a redundant circuit or another system to prevent a single fault causing an unsafe status.

17.2 Design Engineering Notes

- (3) Heat is the major cause of shortening the life of these products. Avoid assembly and use of the target equipment in conditions where the product's temperature may exceed the maximum allowable.
- (4) Failure to do so may result in degrading of the product's functions and damage to the product.
- (5) If pulses or other transient loads (a large load applied in a short time) are applied to the products, before use, check and evaluate their operation when assembled onto your products.

- (6) These products are not intended for other uses, other than under the special conditions shown below. Before using these products under such special conditions, check their performance and reliability under the said special conditions carefully, to determine whether or not they can be used in such a manner.
- (7) In liquid, such as water, salt water, oil, alkali, or organic solvent, or in places where liquid may splash.
- (8) In direct sunlight, outdoors, or in a dusty environment
- (9) In an environment where condensation occurs.
- (10) In an environment with a high concentration of harmful gas (e.g. salty air, HCl, Cl₂, SO₂, H₂S, NH₃, and NO_x)
- (11) If an abnormal voltage is applied due to a problem occurring in other components or circuits, replace these products with new products because they may not be able to provide normal performance even if their electronic characteristics and appearances appear satisfactory.
- (12) Mechanical stress during assembly of the board and operation has to be avoided.
- (13) Pressing on parts of the metal cover or fastening objects to the metal cover is not permitted.

17.3 Storage Conditions

The module must not be stressed mechanically during storage.

Do not store these products in the following conditions or the performance characteristics of the product, such as RF performance, may well be adversely affected:

- (1) Storage in salty air or in an environment with a high concentration of corrosive gas, such as Cl₂, H₂S, NH₃, SO₂, or NO_x
- (2) Storage in direct sunlight
- (3) Storage in an environment where the temperature may be outside the range of 5°C to 35°C range, or where the humidity may be outside the 45 to 85% range.
- (4) Storage (before assembly of the end product) of the modules for more than one year after the date of delivery at your company even if all the above conditions (1) to (3) have been met, should be avoided.

18 Packaging

18.1 Embossed Tape

(1) Dimension of the tape (EIAJ-tbd)

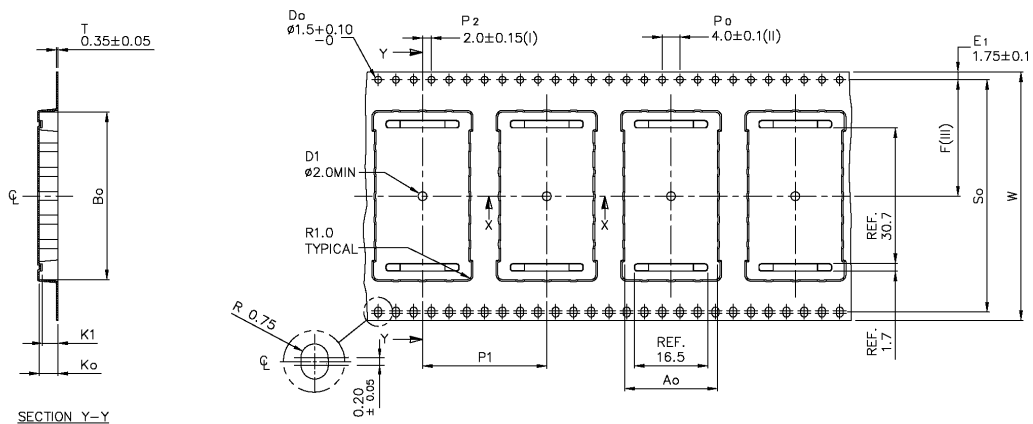

Ao	20.85 +/−0.1
Bo	37.85 +/−0.1
Ko	4.20 +/−0.1
K1	3.55 +/−0.1
F	26.20 +/−0.15
P1	28.00 +/−0.1
So	52.40 +/−0.1
W	56.00 +/−0.3

Forming format : Flatbed
 Estimated max. length : 46 meter/2286 reel

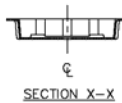

- (I) Measured from centreline of sprocket hole to centreline of pocket.
- (II) Cumulative tolerance of 10 sprocket holes is ± 0.20 .
- (III) Measured from centreline of sprocket hole to centreline of pocket.

ALL DIMENSIONS IN MILLIMETRES UNLESS OTHERWISE STATED.

(2) Cover tape reel strength

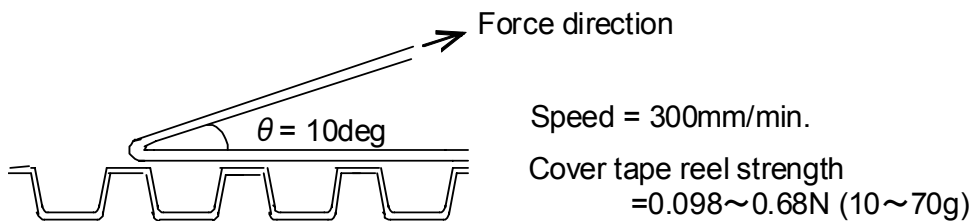

(3) Empty pockets

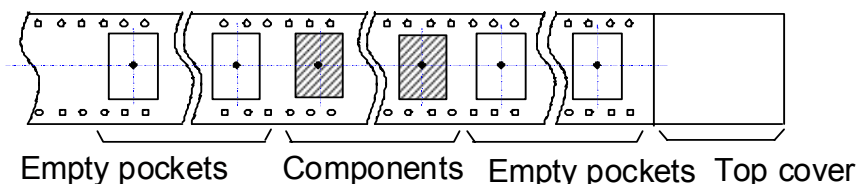

NB: Empty pockets in the component packed area shall be less than two per reel and those empty pockets shall not be consecutive.

18.2 Component Orientation

Top cover tape shall not be found on reel holes and will not stick out from the reel

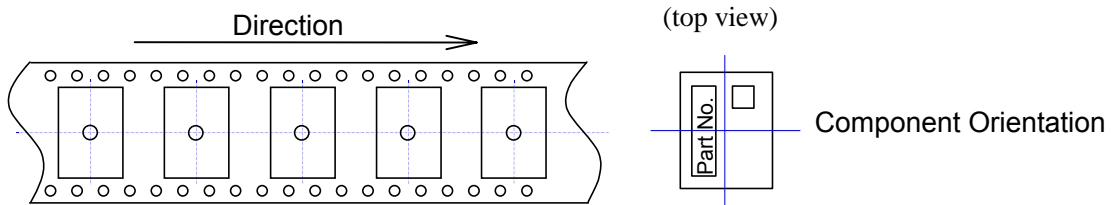

18.3 Reel Dimensions

- (4) Quantity per reel: 400 pieces
- (5) Marking: Part No. / Quantity / Lot No. and manufacturer part# with bar-code will be on the reel.

18.4 Packaging

- (6) Each reel will be packed in a hermetically-sealed bag
- (7) Marking : Part No. / Quantity / Lot No. and manufacturer part# with bar-code will be on the reel

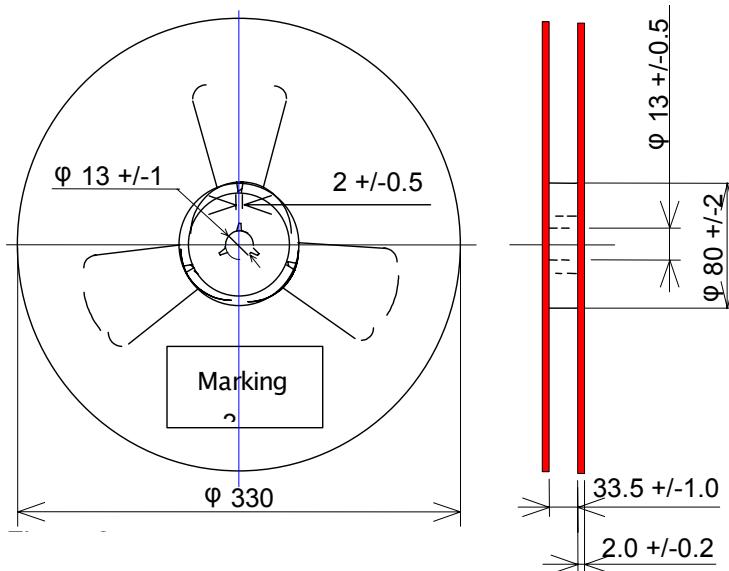

19 Ordering Information

Ordering/Product Code	Description
ETRX2	Telegesis Wireless Mesh Networking Module with Ember ZigBee® Technology: <ul style="list-style-type: none"> • Telegesis AT Style Command Interpreter and • EmberNet2.xx meshing and self-healing stack • Integrated 2.4GHz Antenna • <u>No</u> Harwin Connector
ETRX2HR	Telegesis Wireless Mesh Networking Module with Ember ZigBee® Technology: <ul style="list-style-type: none"> • Telegesis AT Style Command Interpreter and • EmberNet2.xx meshing and self-healing stack • Hirose U.FL Antenna Connector • <u>No</u> Harwin Connector
ETRX2DVKA	Telegesis Development Kit with: <ul style="list-style-type: none"> • 1 x ETRX2HW Module with Board to Board Connector • 1 x ETRXnDV Development Board • 2 x ETRX2 Modules soldered to... • 2 x ETRXnMCB Module Carrier Boards • 2 x AA Battery Holders with Leads & Connector Plugs • 1 x USB cable
ETRX2DVKA-Plus	Telegesis Development Kit with: <ul style="list-style-type: none"> • 1 x ETRX2HW Module with Board to Board Connector • 1 x ETRX2HRHW-PA Module with Board Connector • 1 x ETRXnDV Development Board • 2 x ETRX2 Modules and ... • 1 x ETRX2PA Module soldered to... • 3 x ETRX2MCB Module Carrier Boards • 3 x AA Battery Holders with Leads & Connector Plugs • 1 x ETRX2USB stick • 1 x 1/2 wave antenna • 1 x USB cable

Notes:

- Customers' PO's must state the Ordering/Product Code.
- There is no "blank" version of the ETRX2 Module available. All Modules are pre-programmed with the Telegesis AT style command interpreter based on the EmberZNet stack. (Where customers wish to add their own firmware they can erase and write it to the flash memory of the EM250).
- Please contact Telegesis if you require additional AT style commands or specific integration assistance.

20 Trademarks

All trademarks, registered trademarks and products names are the sole property of their respective owners.

21 Disclaimer

Product and company names and logos referenced may either be trademarks or registered trademarks of their respective companies. We reserve the right to make modifications and/or improvements without prior notification. All information is correct at time of issue. Telegesis (UK) Ltd does not convey any license under its patent rights or assume any responsibility for the use of the described product

22 RoHS Declaration

Declaration of environmental compatibility for supplied products:

Hereby we declare to our best present knowledge based on the declaration of our suppliers that this product does not contain the following substances which are banned by Directive 2002/95/EC (RoHS) or if they do, contain a maximum concentration of 0,1% by weight in homogeneous materials for:

- Lead and lead compounds
- Mercury and mercury compounds
- Chromium (VI)
- PBB (polybrominated biphenyl) category
- PBDE (polybrominated biphenyl ether) category

And a maximum concentration of 0,01% by weight in homogeneous materials for:

- Cadmium and cadmium compounds

23 Data Sheet Status

Telegesis (UK) Ltd. reserves the right to change the specification without notice, in order to improve the design and supply the best possible product. Please consult the most recently issued data sheet before initiating or completing a design.

24 Life Support Policy

This product is not designed for use in life support appliances, devices, or systems where malfunction can reasonably be expected to result in a significant personal injury to the user, or as a critical component in any life support device or system whose failure to perform can be reasonably expected to cause the failure of the life support device or system, or to affect its safety or effectiveness. Customers using or selling these products for use in such applications do so at their own risk and agree to fully indemnify Telegesis (UK) Ltd. for any damages resulting.

25 Related Documents

- [1] IEEE Standard 802.15.4 –2003 Wireless Medium Access Control (MAC) and Physical Layer (PHY) Specifications for Low-Rate Wireless Personal Area Networks (LR-WPANS)
- [2] Datasheet EM250, Ember. (www.ember.com)
- [3] Datasheet U.FL-Series 2004.2 Hirose Ultra Small Surface Mount Coaxial Connectors - Low Profile 1.9mm or 2.4mm Mated Height
- [4] Johanson 2450AT43A100 Antenna datasheet (www.johansontechnology.com)
- [5] The ZigBee® specification (www.zigbee.org)

26 Contact Information

Website: www.telegesis.com
E-mail: sales@telegesis.com

Telegesis (UK) Limited
3, Abbey Barn Business Centre
Abbey Barn Lane
High Wycombe
Bucks
HP10 9QQ
UK

Tel: +44 (0)1494 510199
Fax: +44 (0)5603 436999