

DATA SHEET

# RF Engine<sup>®</sup> Model SM200

Part Numbers: SM200P81 and RF200P81  
SM200PU1 and RF200PU1

*Document Revision v1.4*



Wireless Technology to Control and  
Monitor Anything from Anywhere™

© 2012-2013 Synapse Wireless, All Rights Reserved  
All Synapse products are patented or patent pending  
Specifications are subject to change without notice – confirm that data is current  
Synapse, the Synapse logo, SNAP, and Portal are all registered trademarks of  
Synapse Wireless, Inc.  
500 Discovery Drive  
Huntsville, Alabama 35806  
877-982-7888

Doc # 430145-01C

**This Page Intentionally Blank**

# Table of Contents

---

1.0	RF Engine Model SM200 OEM Modules Overview .....	4
1.1	Specifications .....	5
1.2	Pin Definitions .....	6
1.3	RF Module Pin Compatibility.....	8
1.4	Electrical Characteristics .....	9
1.5	Mechanical Drawings .....	11
1.6	Board Mounting Considerations .....	13
1.6.1	Processing .....	13
1.6.2	Pb-Free Soldering Paste.....	14
1.6.3	Cleaning .....	14
1.6.4	Optical Inspection .....	14
1.6.5	Repeating Reflow Soldering.....	14
1.6.6	Wave Soldering.....	14
1.6.7	Hand Soldering .....	15
1.6.8	Rework.....	15
1.6.9	Additional Grounding .....	15
2.0	Agency Certifications .....	15
2.1	United States (FCC).....	15
2.1.1	OEM Labeling Requirements .....	15
2.1.2	FCC Notices.....	16
2.1.3	FCC Approved Antennas.....	16
2.2	Canada (IC).....	19
2.2.1	IC Approved Antennas .....	19
2.2.2	OEM Labeling Requirements .....	21

## 1.0 RF Engine Model SM200 OEM Modules Overview

The RF Engine Model SM200 includes the SM200P81, SM200PU1, RF200P81 and RF200PU1 part numbers. They are IEEE 802.15.4, low-power, highly reliable solutions to embedded wireless control and monitoring network needs that require high data rates. The Model SM200 embeds Synapse's SNAP OS, the industry's first Internet-enabled, wireless mesh network operating system into the Atmel ATmega128RFA1 single-chip AVR® microcontroller with an integrated transceiver that delivers up to 2Mbps/sec. These low-cost modules can have power consumption as low as 0.37  $\mu$ A to enable a new generation of battery-driven systems.

SNAP's on-board Python interpreter provides for rapid application development and over-the-air programming, while Atmel's low-power RF single-chip design saves board space and lowers the overall Bill of Materials and power consumption. The Model SM200 modules are approved as an FCC Part 15 unlicensed modular transmitters, as well as having CE Certification and IC Certification. The modules provide up to 16 channels of operation in the ISM 2.4GHz frequency band.

### Data Sheet covers Part Numbers SM200P81/PU1 and RF200P81/PU1:

- **SM200P81/PU1:** 38 GPIO with up to 7 A/D inputs
- **RF200P81/PU1:** 20 GPIO with up to 7 A/D inputs
- 128k flash, 58.5k free for over-the-air uploaded user apps
- Two UART ports for control or transparent data
- Low power modes:
  - 0.37  $\mu$ A with external interrupt
  - 1.37  $\mu$ A with internal timer running
- Spread Spectrum (DSSS) technology surmounts noisy environments
- Up to 2 Mbps radio data rate
- 2.4 GHz RF Frequency
- Receive sensitivity -100dBm at 250kbps
- Transmit Power 3 dBm
- Integrated chip antenna or U.FL connector
- **SM200P81/PU1:** Solder-able (surface-mount)
- **RF200P81/PU1:** Solder-able (through-hole), Socket-able



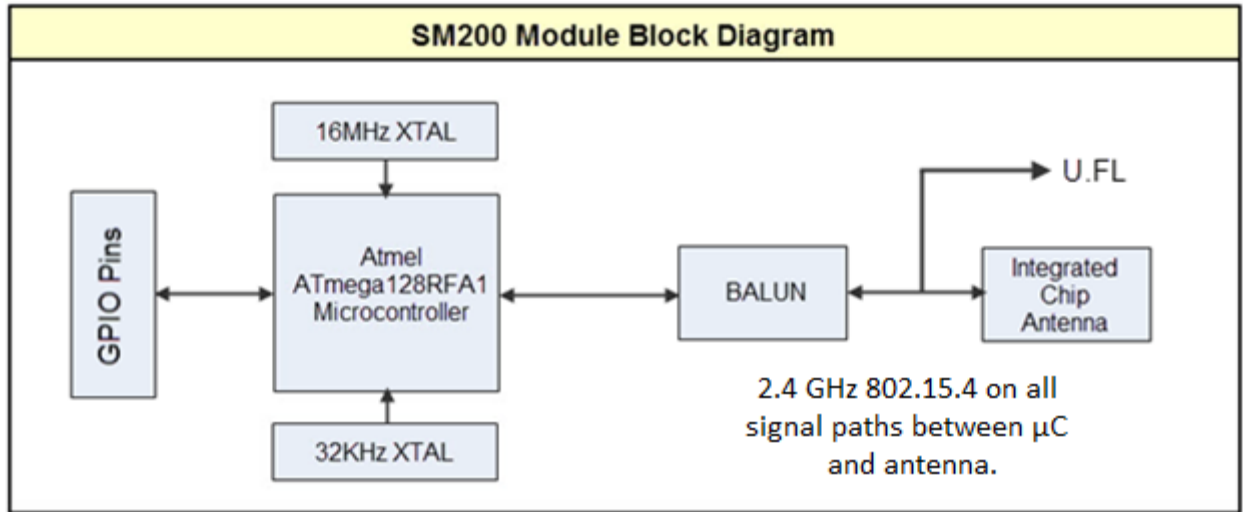

**Figure 1.0** Block diagram showing the major subsystems comprising Model SM200

## 1.1 Specifications

<b>Table 1.0 Specifications</b>		<b>SM200P81/PU1</b>	<b>RF200P81/PU1</b>
<b>Performance</b>	Outdoor LOS Range	Up to 1500/2500 feet at 250Kbps	
	Transmit Power Output	3 dBm	
	RF Data Rate	250Kbps, 500Kbps, 1Mbps, 2Mbps	
	Receiver Sensitivity	-100 dBm (1% PER, 250Kbps)	
<b>Power Requirements</b>	Supply Voltage	1.8 - 3.6 V	
	Transmit Current (Typ@3.3V)	22.5 mA	
	Idle/Receive Current (Typ@3.3V)	20.5 mA	
	Power-down Current (Typ@3.3V)	0.37 μA	
<b>General</b>	Frequency	ISM 2.4 GHz	
	Spreading Method	Direct Sequence (DSSS)	
	Modulation	O-QPSK	
	Dimensions	29.8mm x 19mm	33.86mm x 33.86mm
	Operating Temperature	- 40 to 85 deg C.	
	Antenna Options	Integrated Chip Antenna / External Antenna	
<b>Networking</b>	Topology	SNAP	
	Error Handling	Retries and acknowledgement	
	Number of Channels	16	
<b>Available I/O</b>	UARTS with HW Flow Control	2 Ports - 8 total I/O	
	GPIO	38 total; 7 can be analog-in with 10bit ADC	20 total; 7 can be analog-in with 10bit ADC
<b>Agency Approvals</b>	FCC Part 15.249	FCC ID: U9O-SM200	FCC ID: U9O-SM200
	Industry Canada (IC)	IC: 7084A-SM200	IC: 7084A-SM200
	CE Certified	Yes	Yes

## 1.2 Pin Definitions

**Table 1.1 SM200P81/PU1 and RF200P81/PU1 Pin Assignments**

SM200 Pin	RF200 Pin	Pin Name	SNAPpy IO	Pin Description
A1	1, 24	GND		Power Supply
A2	21	VCC		Power Supply
A3	21	VCC		Power Supply
A4	13	PF0_ADC0	24	IO or Analog0
A5	15	PF2_ADC2_DIG2	26	IO or Analog2 or SPI CLK or Antenna Diversity Control
A6	17	PF4_ADC4_TCK	28	IO or Analog4 or JTAG Test Clock
A7	19	PF6_ADC6_TDO	30	IO or Analog6 or JTAG Test Data Out or I <sup>2</sup> C SDA
A8	1, 24	GND		Power Supply
B1	16	PE2_XCK0_AIN0	18	IO or SPI MISO or Analog Comparator or External Clock
B2	22	PE3_OC3A_AIN1	19	IO or Analog Comparator or PWM or Output Compare Match <sup>1</sup>
B3	8	PE5_OC3C_INT5	21	IO or UART0 RTS Input or PWM or Interrupt
B4	14	PF1_ADC1	25	IO or Analog1 or SPI MOSI
B5		PG1_DIG1	33	IO or Antenna Diversity Control
B6	18	PF5_ADC5_TMS	29	IO or Analog5 or JTAG Test Mode Select
B7	20	PF7_ADC7_TDI	31	IO or Analog7 or JTAG Test Data In or I <sup>2</sup> C SCL
B8	1, 24	GND		Power Supply
C1	5	PE0_RXD0_PCINT8	16	IO or UART0 Data In or Interrupt
C2	6	PE1_TXD0	17	IO or UART0 Data Out
C3	7	PE4_OC3B_INT4	20	IO or UART0 CTS Output or PWM or Interrupt
C4		PE6_T3_INT6	22	IO or Interrupt
C5	12	PE7_ICP3_INT7_CLK0	23	IO or UART1 RTS input or Clock Output Buffer or Interrupt
C6		NC		
C7		NC		
C8	1, 24	GND		Power Supply
D1	4	PB5_OC1A_PCINT5	5	IO or PWM or Interrupt
D2	3	PB6_OC1B_PCINT6	6	IO or PWM or Interrupt
D3	2	PB7_OC0A_OC1C_PCINT7	7	IO or PWM or Interrupt
D4		NC		
D5		NC		
D6		NC		
D7		NC		
D8	1, 24	GND		Power Supply

**Table 1.1 SM200P81/PU1 and RF200P81/PU1 Pin Assignments**

SM200 Pin	RF200 Pin	Pin Name	SNAPpy IO	Pin Description
E1		PB2_MOSI_PCINT2 <sup>2</sup>	2	IO or Interrupt
E2		PB3_MISO_PCINT3 <sup>2</sup>	3	IO or Interrupt
E3		PB4_OC2A_PCINT4	4	IO or PWM or Interrupt
E4		NC		
E5		NC		
E6		NC		
E7		NC		
E8		RF OUT		50 Ohm RF output on specially ordered devices (Contact Synapse Wireless for details). Otherwise, no connect.
F1		PB0_SSN_PCINT0 <sup>2</sup>	0	IO or Interrupt
F2		PB1_SCK_PCINT1 <sup>2</sup>	1	IO or Interrupt
F3		PD1_SDA_INT1 <sup>2</sup>	9	IO or Interrupt
F4		PD0_SCL_INT0 <sup>2</sup>	8	IO or Interrupt
F5		NC		
F6		NC		
F7		NC		
F8	1, 24	GND		Power Supply
G1		CLKI		<i>Must be pulled low during normal operation</i>
G2		PD7_T0	15	IO
G3	11	PD4_ICP1	12	IO or UART1 CTS output or Input Capture
G4	9	PD2_RXD1_INT2	10	IO or UART1 Data In or Interrupt
G5		PG5_OC0B	37	IO or PWM
G6		NC		
G7		NC		
G8	1, 24	GND		Power Supply
H1	1, 24	GND		Power Supply
H2		PD6_T1	14	IO or Timer/Counter1 clock input
H3		PD5_XCK1	13	IO
H4	10	PD3_TXD1_INT3	11	IO or UART1 Data Out or Interrupt
H5	23	RESET#		Module Reset, Active Low
H6		TST		<i>Must be pulled low during normal operation</i>
H7		NC		
H8	1, 24	GND		Power Supply

<sup>1</sup> Other SNAP Engines have a debug connection on pin 22. The architecture of the RF200 requires multiple debug connections, which come out on other pins. Rather than leave pin 22 useless, it is available as an additional GPIO or Analog Comparator. This will not be directly accessible on Synapse development boards, but custom circuit designs have the pin available for specialized purposes.

<sup>2</sup> These pins have special I<sup>2</sup>C and SPI hardware that is not natively supported by SNAP. You could use peek and poke to initialize and enable this hardware functionality. Use at your own risk!

## 1.3 RF Module Pin Compatibility

Table 1.2 SM200P81/PU1 Module Pin Assignments			
RF200 Pin	SM200 Pin	Name	Description
1	A1, A8, B8, C8, D8, F8, G8, H1, H8	GND	Power Supply
2	D3	GPIO0/OC0A/OC1C/PCINT7/PB7/IO7	GPIO_0, PWM, or Interrupt
3	D2	GPIO1/OC1B/PCINT6/PB6/IO6	GPIO_1, PWM, or Interrupt
4	D1	GPIO2/OC1A/PCINT5/PB5/IO5	GPIO_2, PWM, or Interrupt
5	C1	GPIO3/RXD0/PCINT8/PE0/IO16	GPIO_3, Interrupt, or UART0 Data Input
6	C2	GPIO4/TXD0/PE1/IO17	GPIO_4, UART0 Data Output
7	C3	GPIO5/OC3B/INT4/PE4/IO20	GPIO_5, PWM, Interrupt, or UART0 CTS Output
8	B3	GPIO6/OC3C/INT5/PE5/IO21	GPIO_6, PWM, Interrupt, or UART0 RTS Input
9	G4	GPIO7/RXD1/INT2/PD2/IO10	GPIO_7, Interrupt, or UART1 Data Input
10	H4	GPIO8/TXD1/INT3/PD3/IO11	GPIO_8, Interrupt, or UART1 Data Output
11	G3	GPIO9/ICP1/PD4/IO12	GPIO_9, or UART1 CTS Output
12	C5	GPIO10/ICP3/INT7/CLK0/PE7/IO23	GPIO_10, Interrupt, Clock Output, or UART1 RTS Input
13	A4	GPIO11/ADC0/PF0/IO24	GPIO_11, or Analog In
14	B4	GPIO12/ADC1/PF1/IO25	GPIO_12, SPI MOSI, or Analog In
15	A5	GPIO13/ADC2/DIG2/PF2/IO26	GPIO_13, SPI SCLK, Antenna Diversity, or Analog In
16	B1	GPIO14/XCK0/AIN0/PE2/IO18	GPIO_14, SPI MISO, USART CLK, Analog Comparator, or Analog In
17	A6	GPIO15/ADC4/TCK/PF4/IO28	GPIO_15, JTAG TCK, or Analog In
18	B6	GPIO16/ADC5/TMS/PF5/IO29	GPIO_16, JTAG TMS, or Analog In
19	A7	GPIO17/ADC6/TDO/PF6/IO30	GPIO_17, JTAG TDO, I2C SDA, or Analog In
20	B7	GPIO18/ADC7/TDI/PF7/IO31	GPIO_18, JTAG TDI, I2C SCL, or Analog In
21	A2, A3	VCC	Power Supply
22	B2	GPIO19/OC3A/AIN1/PE3/IO19	GPIO_19, PWM, Analog Comparator
23	H5	RESET	Module Reset, Active Low
24	A1, A8, B8, C8, D8, F8, G8, H1, H8	GND	Power Supply



## 1.4 Electrical Characteristics

Table 1.3 DC Characteristics						
Symbol	Parameter	Condition	Min	Typ <sup>1</sup>	Max	Units
V <sub>CC</sub> <sup>2</sup>	Supply Voltage		1.8	3.3	3.6	V
T <sub>OP</sub>	Operating Temp		-40		85	°C
V <sub>IH</sub>	Input Hi Voltage	All Digital Inputs	V <sub>CC</sub> - 0.4			V
V <sub>IL</sub>	Input Low Voltage	All Digital Inputs			0.4	V
V <sub>OL</sub>	Output Low Voltage	All drive strengths (2,4,6,8 mA)			0.4	V
V <sub>OH</sub>	Output High Voltage	All drive strengths (2,4,6,8 mA)	V <sub>CC</sub> - 0.4			V
I <sub>LIN</sub>	In Leakage Current	V <sub>IN</sub> =V <sub>CC</sub> or V <sub>SS</sub> , all Pins		<10nA	1	µA
TX-I <sub>CC</sub>	Transmit Current	V <sub>CC</sub> = 3.3V P <sub>TX</sub> =3dBm		14.5 <sup>3</sup>		mA
RX-I <sub>CC</sub>	Receive Current	V <sub>CC</sub> = 3.3V		12.5 <sup>3</sup>		mA
SHDN-I <sub>CC</sub>	Sleep Current	V <sub>CC</sub> = 3.3V		0.25		µA

<sup>1</sup> All typical specifications are measured at 25°C.

<sup>2</sup> Absolute maximum stress rated voltage for VCC is -0.3 to 3.6. It is recommended that a bulk decoupling capacitor (47 µF tantalum rated at 6.3volts) be located close to the VCC pin 21 of the SM200 connector on host board.

<sup>3</sup> 2.4GHz transceiver current only. Does not include current required to run CPU.

Table 1.4 ADC Electrical Characteristics (Operating)						
Symbol	Parameter	Condition	Min	Typical	Max	Unit
V <sub>REFH</sub> <sup>4</sup>	Voltage Reference, High	Programmable	1.5	1.6	1.8	V
V <sub>INDC</sub>	Analog input voltage	Single Ended	0		1.8	V
		Differential <sup>5</sup>	0		3.3	

<sup>4</sup> V<sub>REFH</sub> is programmable to three fixed values; 1.5V, 1.6V, and 1.8V. The default is 1.6V.

<sup>5</sup> Each differential analog input may be as high as 3.3V but the single-ended voltage is still limited to the voltage reference.

Table 1.5 ADC Timing/Performance Characteristics						
Symbol	Parameter	Condition	Min	Typical	Max	Unit
R <sub>AS</sub>	Source impedance at input <sup>6</sup>				3k	kΩ
RES	Conversion Resolution	Single Ended CLKADC ≤ 4MHz		10		Bits
		Single Ended CLKADC > 8MHz		8		
DNL	Differential non-linearity	V <sub>REFH</sub> = 1.6V CLKADC=4MHz	-0.5			LSB
INL	Integral non-linearity	V <sub>REFH</sub> = 1.6V CLKADC=4MHz		0.8		LSB
E <sub>ZS</sub>	Zero-scale error			1.5		LSB
E <sub>G</sub>	Gain error			1		LSB

<sup>6</sup> Any analog source with a source impedance greater the 3kΩ will increase the sampling time.

<b>Table 1.6 Reset, Brown-out and Internal Voltage Characteristics</b>						
<b>Symbol</b>	<b>Parameter</b>	<b>Condition</b>	<b>Min</b>	<b>Typical</b>	<b>Max</b>	<b>Unit</b>
$V_{POT(rising)}$	Power-on Reset Threshold Voltage (rising)	Power supply fully discharged		1.6		V
$V_{POT(falling)}$	Power-on Reset Threshold Voltage (falling)		0.05	0.3		V
$t_{POT}$	Power-on Reset recovery time	Time of EVDD/DEVDD < $V_{POT}$	1.0			ms
$V_{PSR}$	Power-on slope rate		1.8		3300	V/ms
$V_{RST}$	RSTN Pin Threshold Voltage		$0.1V_{DD}$		$0.9V_{DD}$	V
$t_{RST}$	Minimum pulse width on RSTN Pin			200	300	ns
$V_{HYS}$	Brown-out Detector Hysteresis			7.5	50	mV
$t_{BOD}$	Min Pulse Width on Brown-out Reset			100		ns

Contact ATMEL for additional details



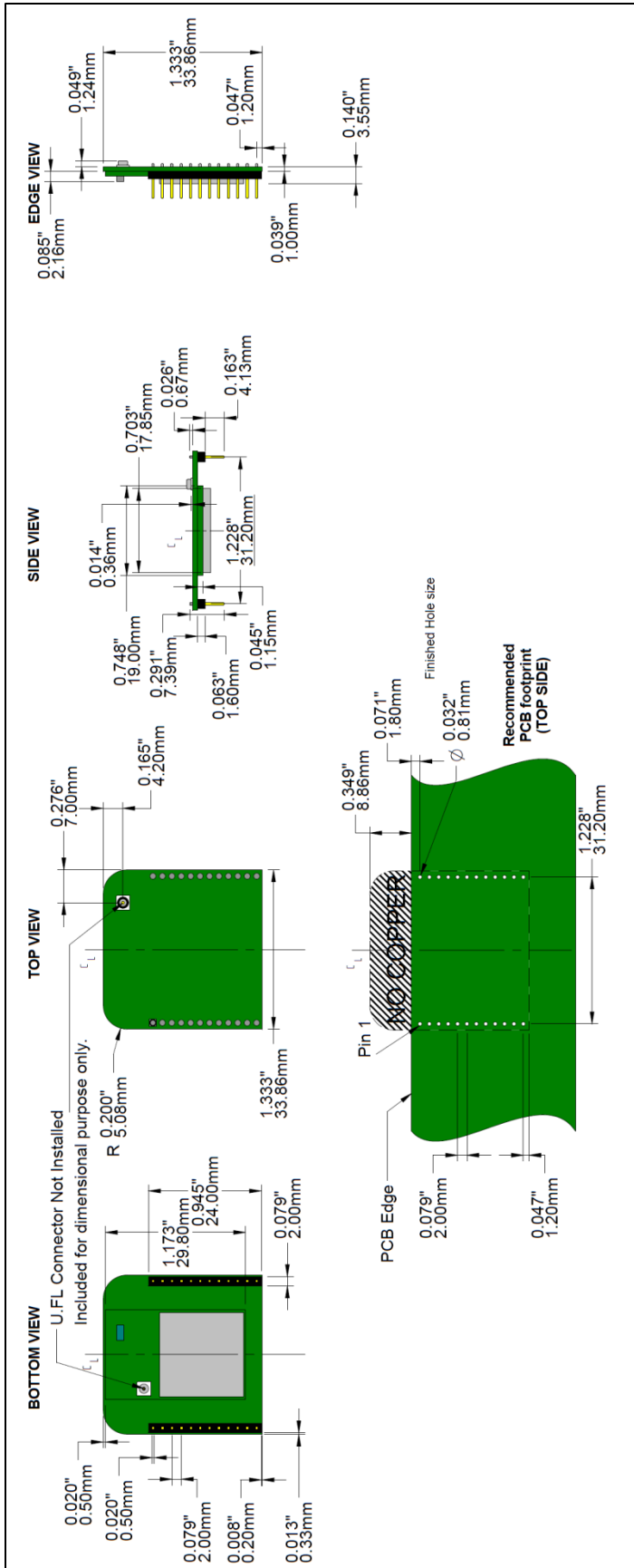

Download Figure 1.2,  
RF200P81/PU1 Mechanical Drawing  
in [PDF](#), [DXF](#), or [DFI](#) format.

## 1.6 Board Mounting Considerations

### 1.6.1 Processing

Table 1.7 Recommended Reflow Profile	
Parameter	Value
Ramp up rate (from Tsoakmax to Tpeak)	3°/sec max
Minimum Soak Temperature	150°C
Maximum Soak Temperature	200°C
Soak Time	60-120 sec
TLiquidus	217°C
Time above TL	30-60 sec (recommended: 40 sec)
Tpeak	230° - 250°C (recommended: 235°C)
Time within 5° of Tpeak	20-30 sec
Time from 25° to Tpeak	8 min max
Ramp down rate	6°C/sec max

Achieve the brightest possible solder fillets with a good shape and low contact angle.

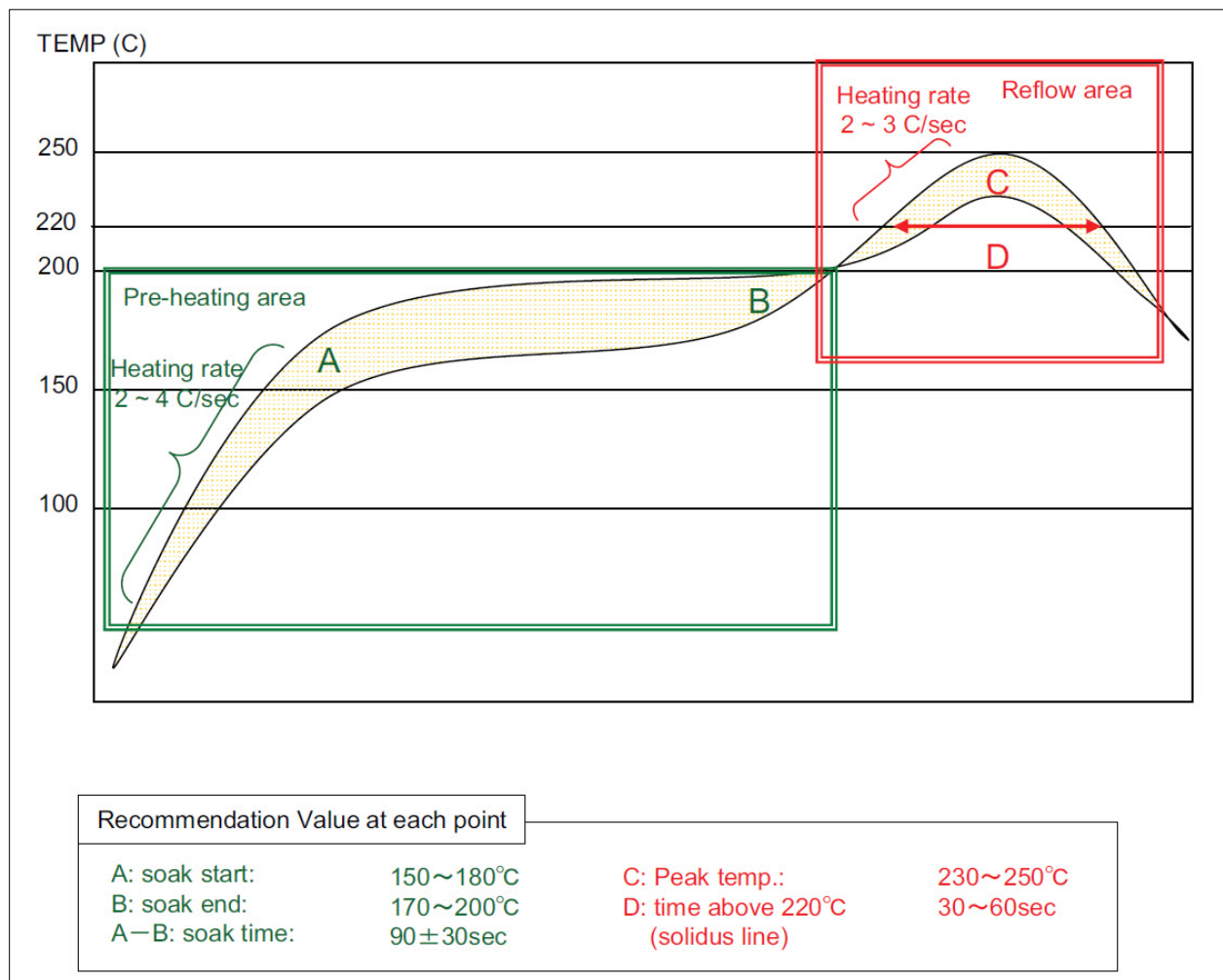

## 1.6.2 Pb-Free Soldering Paste

Use of “No Clean” soldering paste is strongly recommended, as it does not require cleaning after the soldering process.

## 1.6.3 Cleaning

In general, cleaning the populated modules is strongly discouraged. Residuals under the module cannot be easily removed with any cleaning process.

- Cleaning with water can lead to capillary effects where water is absorbed into the gap between the host board and the module. The combination of soldering flux residuals and encapsulated water could lead to short circuits between neighboring pads. Water could also damage any stickers or labels.
- Cleaning with alcohol or a similar organic solvent will likely flood soldering flux residuals into the two housings, which is not accessible for post-washing inspection. The solvent could also damage any stickers or labels.
- Ultrasonic cleaning could damage the module permanently.

The recommended approach is to consider using a “no clean” soldering paste and eliminate the post-soldering cleaning step.

## 1.6.4 Optical Inspection

After soldering the Module to the host board, consider optical inspection to check the proper alignment and centering of the module over the pads.

## 1.6.5 Repeating Reflow Soldering

Only a single reflow soldering process is encouraged for host boards.

## 1.6.6 Wave Soldering

If a wave soldering process is required on the host boards due to the presence of leaded components, only a single wave soldering process is encouraged.

## 1.6.7 Hand Soldering

Hand soldering is possible. Use a soldering iron temperature setting equivalent to 350°C and follow IPC recommendations/reference document [IPC-7711](#).

## 1.6.8 Rework

The Model SM700 Module can be unsoldered from the host board. Use of a hot air rework tool and hot plate for pre-heating from underneath is recommended. Avoid overheating.

**Warning:** Never attempt a rework on the module itself (e.g. replacing individual components). Such actions will terminate warranty coverage.

## 1.6.9 Additional Grounding

Attempts to improve module or system grounding by soldering braids, wires, or cables onto the module RF shield cover is done at the customers own risk. The numerous ground pins at the module perimeter should be sufficient for optimum immunity to external RF interference.

## 2.0 Agency Certifications

### 2.1 United States (FCC)

The Model SM200 module complies with Part 15 of the FCC rules and regulations. Compliance with the labeling requirements, FCC notices and antenna usage guidelines is required. In order to comply with FCC Certification requirements, the Original Equipment Manufacturer (OEM) must fulfill the following requirements.

1. The system integrator must place an exterior label on the outside of the final product housing the SM200 Modules. Figure 2.1 shows the contents that must be included in this label.
2. SM200 Modules may only be used with the antenna that has been tested and approved for use with the module. Please refer to the antenna table provided in this section.

#### 2.1.1 OEM Labeling Requirements

**NOTICE:** The OEM must make sure that FCC labeling requirements are met. This includes a clearly visible exterior label on the outside of the final product housing that displays the contents shown in Figure 2.1.

MANUFACTURER'S NAME  
BRAND NAME or TRADE NAME  
MODEL:

**Figure 2.1 FCC Label**

Contains Model SM200 FCC ID: U9O-SM200

This device complies with Part 15 of the FCC Rules. Operation is subject to the following two conditions: (1) This device may not cause harmful interferences, and (2) this device must accept any interference received, including interference that may cause undesired operation.

## 2.1.2 FCC Notices

**WARNING:** The SM200 modules have been tested by the FCC for use with other products without further certification (as per FCC Section 2.1091). Changes or modifications to this device not expressly approved by Synapse Wireless Inc. could void the user's authority to operate the equipment.

**NOTICE:** OEMs must certify final end product to comply with unintentional radiators (FCC Section 15.107 and 15.109) before declaring compliance of their final product to Part 15 of the FCC Rules.

This equipment has been tested and found to comply with the limits for a Class B digital device, pursuant to Part 15 of the FCC Rules. These limits are designed to provide reasonable protection against harmful interference in a residential installation. This equipment generates, uses, and can radiate radio frequency energy and, if not installed and used in accordance with the instructions, may cause harmful interference to radio communications. However, there is no guarantee that interference will not occur in a particular installation.

If this equipment does cause harmful interference to radio or television reception, which can be determined by turning the equipment off and on, the user is encouraged to try to correct the interference by one or more of the following measures:

- Reorient or relocate the receiving antenna.
- Increase the separation between the equipment and receiver.
- Connect the equipment into an outlet on a circuit different from that to which the receiver is connected.
- Consult the dealer or an experienced radio/TV technician for help.

## 2.1.3 FCC Approved Antennas

**Notice:** To reduce potential radio interference to other users, the antenna type and its gain should be chosen so that the equivalent isotropically radiated power (e.i.r.p.) is not



more than that permitted for successful communication. This module has been designed to operate with the antennas listed in Table 2.1.3a and 2.1.3b. The required antenna impedance is 50 ohms.

Table 2.1.3a SM/RF200P81 Approved FCC Antennas				
Part Number	Type	Gain	Application	Min. Separation
Murata LDA312G4413H-280	Chip	-2.3 dBi	Fixed/Mobile	20 cm.

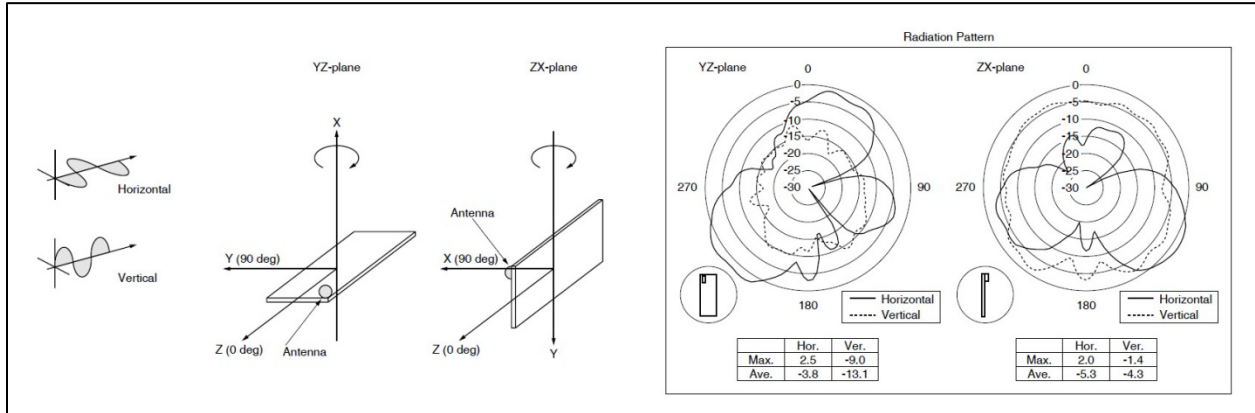
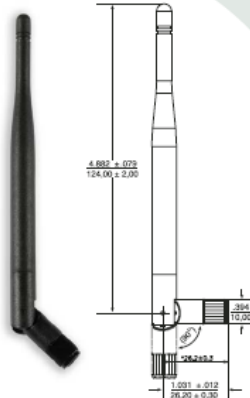

Table 2.1.3b SM/RF200PU1 Approved FCC Antennas				
Part Number	Type	Gain	Application	Min. Separation
Pulse W1027	Dipole (quarter-wave RPSMA)	3.2 dBi	Fixed/Mobile	20 cm.

# Wireless External Antenna for 2.4 GHz Applications

Pulse Part Number: W1027



## Features

- High gain antenna
- For WLAN devices using WiFi (802.11b/g), Bluetooth® and ZigBee™
- Omni-directional radiation pattern provides broad 360° coverage
- One-quarter wavelength dipole configuration
- Connection and color options easily integrate with OEM designs

## Color Options

- Black\*
- Gray (Pantone cool gray 8C)

## Connector Options

- Reverse SMA (Male)\*
- SMA (Male)

\* Default Configuration – Please contact Pulse Applications Engineering for assistance in ordering colors and connectors

Weight.....13.9 grams  
Carton.....20/bag; 500/carton

Dimensions:  $\frac{\text{Inches}}{\text{mm}}$   
Unless otherwise specified, all tolerances are  $\pm \frac{.010}{0.25}$

## Electrical Specifications @ 25 °C

Note: This part number is lead-free and RoHS compliant. No additional suffix or identifier is required.

Antenna Part No.	Frequency [GHz]	Gain [dBi]	Impedance [Nom]	VSWR	Polarization	Electrical Length	Radiation	Color
W1027	2.4 – 2.5	3.2	50 Ω	≤ 1.9	Vertical	1/4, dipole	Omni	Black

## 2.2 Canada (IC)

This device complies with Industry Canada license-exempt RSS standard(s). Operation is subject to the following two conditions: (1) this device may not cause interference, and (2) this device must accept any interference, including interference that may cause undesired operation of the device.

*Le présent appareil est conforme aux CNR d'Industrie Canada applicables aux appareils radio exempts de licence. L'exploitation est autorisée aux deux conditions suivantes : (1) l'appareil ne doit pas produire de brouillage, et (2) l'utilisateur de l'appareil doit accepter tout brouillage radioélectrique subi, même si le brouillage est susceptible d'en compromettre le fonctionnement.*

Under Industry Canada regulations, this radio transmitter may only operate using an antenna of a type and maximum (or lesser) gain approved for the transmitter by Industry Canada. To reduce potential radio interference to other users, the antenna type and its gain should be so chosen that the equivalent isotropically radiated power (e.i.r.p.) is not more than that necessary for successful communication.

*Conformément à la réglementation d'Industrie Canada, le présent émetteur radio peut fonctionner avec une antenne d'un type et d'un gain maximal (ou inférieur) approuvé pour l'émetteur par Industrie Canada. Dans le but de réduire les risques de brouillage radioélectrique à l'intention des autres utilisateurs, il faut choisir le type d'antenne et son gain de sorte que la puissance isotrope rayonnée équivalente (p.i.r.e.) ne dépasse pas l'intensité nécessaire à l'établissement d'une communication satisfaisante.*

### 2.2.1 IC Approved Antennas

This radio transmitter Model: SM200, IC: 7084A-SM200 has been approved by Industry Canada to operate with the antenna types listed below with the maximum permissible gain and required antenna impedance for each antenna type indicated. Antenna types not included in this list, having a gain greater than the maximum gain indicated for that type, are strictly prohibited for use with this device.

*Le présent émetteur radio Model : SM200, IC : 7084A-SM200 a été approuvé par Industrie Canada pour fonctionner avec les types d'antenne énumérés ci-dessous et ayant un gain admissible maximal et l'impédance requise pour chaque type d'antenne. Les types d'antenne non inclus dans cette liste, ou dont le gain est supérieur au gain maximal indiqué, sont strictement interdits pour l'exploitation de l'émetteur.*

Table 2.2.1a Approved IC Antennas				
Part Number	Type	Gain	Application	Min. Separation
Murata LDA312G4413H-280	Chip	-2.3 dBi	Fixed/Mobile	20 cm.

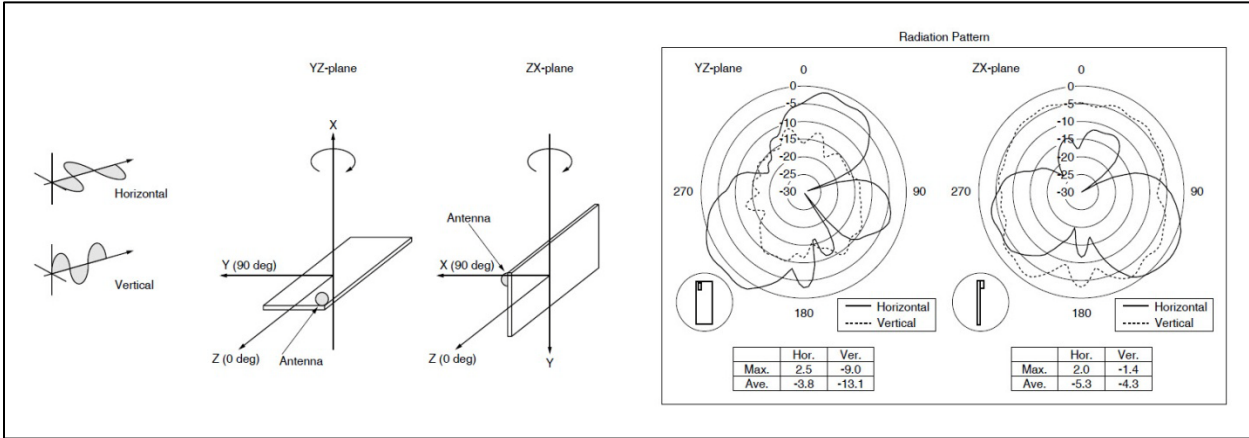

Table 2.2.1b Approved IC Antennas				
Part Number	Type	Gain	Application	Min. Separation
Pulse W1027	Dipole (quarter-wave RPSMA)	3.2 dBi	Fixed/Mobile	20 cm.

Wireless External Antenna for 2.4 GHz Applications  
Pulse Part Number: W1027

**Features**

- High gain antenna
- For WLAN devices using WiFi (802.11b/g), Bluetooth\* and ZigBee™
- Omni-directional radiation pattern provides broad 360° coverage
- One-quarter wavelength dipole configuration
- Connection and color options easily integrate with OEM designs

**Color Options**

- Black\*
- Gray (Pantone cool gray 8C)

**Connector Options**

- Reverse SMA (Male)\*
- SMA (Male)

\* Default Configuration – Please contact Pulse Applications Engineering for assistance in ordering colors and connectors

Weight: 13.9 grams  
Carton: .20/bag; 500/carton

Dimensions: Inches mm  
Unless otherwise specified, all tolerances are ± 0.10 / 0.25

**Electrical Specifications @ 25 °C**  
Note: This part number is lead-free and RoHS compliant. No additional suffix or identifier is required.

Antenna Part No.	Frequency [GHz]	Gain [dBi]	Impedance [Norm]	VSWR	Polarization	Electrical Length	Radiation	Color
W1027	2.4 – 2.5	3.2	50 Ω	≤ 1.9	Vertical	1/4, dipole	Omni	Black

## 2.2.2 OEM Labeling Requirements

Labeling requirements for Industry Canada are similar to those of the FCC. A clearly visible label on the outside of the final product housing must display the contents shown in Figure 2.2.

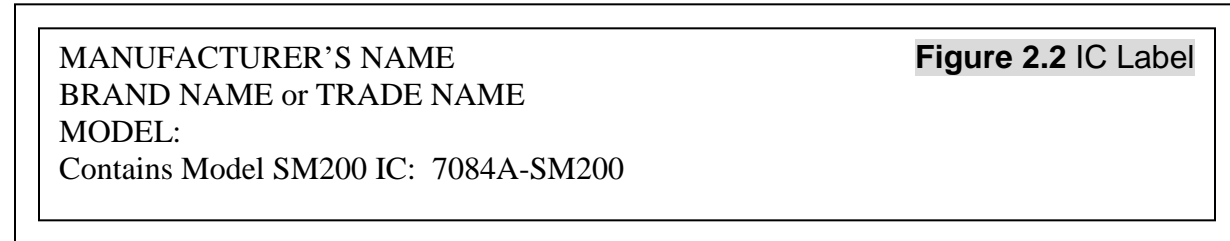

**NOTE:** The OEM can choose to implement a single label combined for both FCC and IC labeling requirements. If a combined single label is chosen, there must be a clearly visible label on the outside of the final product housing displaying the contents shown in Figure 2.3.

