



CH Products introduces a compact and stylish addition to its range of professional USB desktop joysticks, the RS Desktop. Incorporating the latest generation Hall effect positioning sensor, the RS Desktop features a three axes joystick with 12 bit resolution, delivering superior control for PTZ cameras. Supporting USB 1.1 HID "game controller" interface for "plug-and-play" connectivity, the RS Desktop is easy to use and compatible with a wide variety of video surveillance software applications. Combining flexibility with high performance and a stylish design, the RS Desktop is an ideal choice for professional surveillance monitoring applications.



KEY FEATURES

- Three axes Hall effect joystick
- Ergonomic design for left or right hand use
- 12 bit resolution
- Six tactile pushbuttons
- USB interface

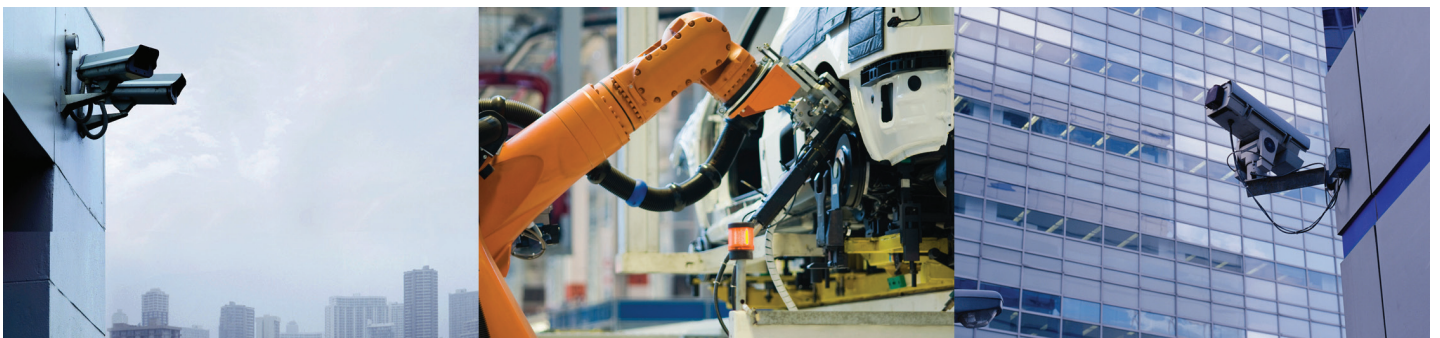

RS Desktop

USB desktop joystick

TECHNICAL SPECIFICATIONS

Joystick performance:	Hall effect three axes joystick X/Y/Z for positioning control Joystick travel: X/Y axes +/-18°, Z axis +/-30° Centering: single spring, omni-directional Joystick shaft: stainless steel Joystick boot: silicone Joystick handle: glass filled nylon
Pushbutton performance:	Six long life tactile switches
Desktop housing:	High impact ABS
Power:	Via the USB interface (5V DC) Consumption 100mA
Operating conditions:	- 25°C to +70°C (-13°F to +158°F)
Approvals:	EN 55024:1998, EN 55022, CE FCC Part 15 Subpart B Class B RoHS compliant
Interface:	USB port
Connectors:	USB Type A Male Cable Length: 2m; 6ft. 6.8in
System support integration:	Windows 7, Vista, XP, 2000
Supported protocols:	USB HID 1.1 game controller Direct X (Gaming Control) Joystick: Three HID axes Pushbuttons: 6 HID buttons Uses standard DirectX HID drivers Connects directly to workstation PC
Environmental:	For indoor use only

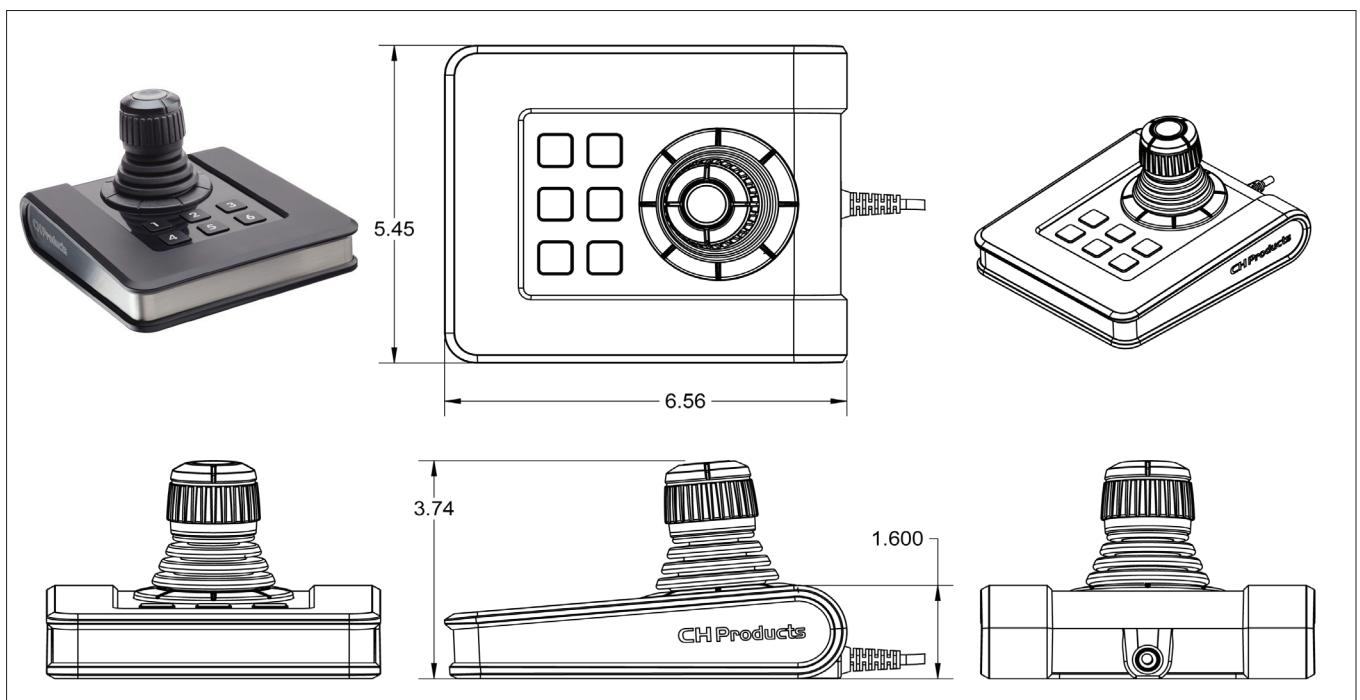

Note: The company reserves the right to change specifications without notice.