



The RSF40 series is designed as a compact internal fitting device, with a wide range of options, making this ideal for size sensitive applications. Mounting of this series requires access to the inside of the tank.

Typical applications include vending machines, commercial washing machines and evaporator units.

They are manufactured in a variety of materials, with a choice of gasket materials, to suit most commonly used liquids.

The switch action may be reversed by rotating the device through 180°.

Some of these types are also available with 1/2" BSF thread.



- **Compact design**
- **Reliable reed switch contacts**
- **Available in Nylon, Acetal, Polypropylene or PPS**
- **WRAS approval**
- **Many variants are UL recognised components file number E171218**

Technical Specification	RSF41	RSF43	RSF44	RSF46
Material	Acetal	Nylon	Polypropylene	Polyphenylene Sulphide (PPS)
Colour	Red	Black	Opaque	Grey
Temp. Range °C	-10 / +60	-20 / +75	-20 / +100	-10 / +120*
°F	+14 / +140	-4 / +167	-4 / +212	+14 / +248*
Min. Fluid S.G.	0.875	0.85	0.85	0.85
Must Close Level (S.G.=1)	5mm	7mm	8mm	9mm
Must Open Level (S.G.=1)	18mm	20mm	20mm	24mm

*Maximum temperature requires ETFE cable to be specified.

Electrical Specification	
Contact Form	N/O (N/C)
Switching Power Max. VA	25
Switching Voltage AC Max.	240
Switching Voltage DC Max.	120
Switching Current Max. A	0.6

All ratings are for resistive load only.

Standard Parts	Material	Leadouts	Gaskets
RSF43Y100RF	Nylon	1.0m PVC 16/0.2 UL approved	Nitrile
RSF44Y100RF	Polypropylene	1.0m PVC 16/0.2 UL approved	Nitrile
RSF46Y100RF	PPS	1.0m PVC 16/0.2 UL approved	Nitrile

Custom versions can be made for particular applications. Please contact Cynergy3 with your requirements.

USA

Cynergy3 Components
2320 Paseo de las Americas, Suite 104
San Diego, CA 92154
Sales & Tech Support (866) 258-5057
Email: sales@cynergy3.com

EUROPE - UK

Cynergy3 Components Ltd.
7 Cobham Road
Ferndown Industrial Estate
Wimborne, Dorset BH21 7PE
Telephone +44 (0) 1202 897969
Fax +44 (0) 1202 891918
Email:sales@cynergy3.com

Mechanical Dimensions

All dimensions are in millimeters (inches)

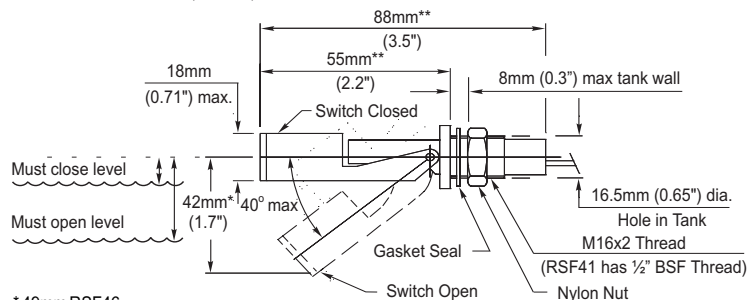

* 49mm RSF46

** Add 10mm to dims, RSF46