



# ENFIS QUATTRO Mini Array Green 520nm

The latest in ultra bright, chip on board, LED lattice arrays.  
Compact, single colour spot source.

## Features

### Mounted array for simple incorporation

- Array mounted on connectorized PCB
- Drop-in capability into existing luminaires
- Incorporating thermal measurement device
- Designed for passive or active cooling

### Densely packed lattice CoB array

- 144 LEDs in 4cm<sup>2</sup>
- Superior dynamic range
- Ultra bright output

### High power useable light

- Drive to 200W
  - Potential for pulsing together with analogue and PWM dimming
- ### Rugged and proven
- Superior >20,000 hour lifetime
  - Reliable and repeatable performance operated in the harshest of environments

### Inbuilt monitoring / control

- Potential for active monitoring and closed loop feedback and control of light output using integrated and calibrated photodiodes
- Inbuilt capability for temperature monitoring control and protection via integrated temperature sensors

## PCB Arrays

Enfis can reduce the time, cost and risk of integration by offering purpose mounted ultra-bright multi-channel/colour arrays. These can be readily driven by appropriate drivers.

## Smart Array Technology

Light output from Enfis Quattro-Mini arrays may be monitored and controlled via patent-pending integrated photo-detection system, enabling precise control and repeatable light output.

## Thermal Management

Enfis Quattro-Mini arrays are designed to provide excellent thermal conductivity and integrate simply providing optimum performance and lifetime.

## Optics

Enfis Quattro-Mini arrays provide a compact spot source with Lambertian emission characteristics. Enfis technical experts can advise a range of optical solutions to match your requirements.

## Applications & Markets

- ◆ **Architectural lighting**
  - Exterior buried spotlights
  - Exterior floodlights
  - Exterior/interior wall-washing
- ◆ **Entertainment lighting**
  - Club/bar lighting
  - Theatre spot gel replacement
  - Moving spots
- ◆ **Fibre optic lighting**
  - Illuminator light sources
- ◆ **Industrial/Scientific lighting**
  - Forensic investigation
  - Fluorescence and Spectroscopy
  - Machine Vision and inspection
  - Projection & backlighting systems
  - Vehicle lighting

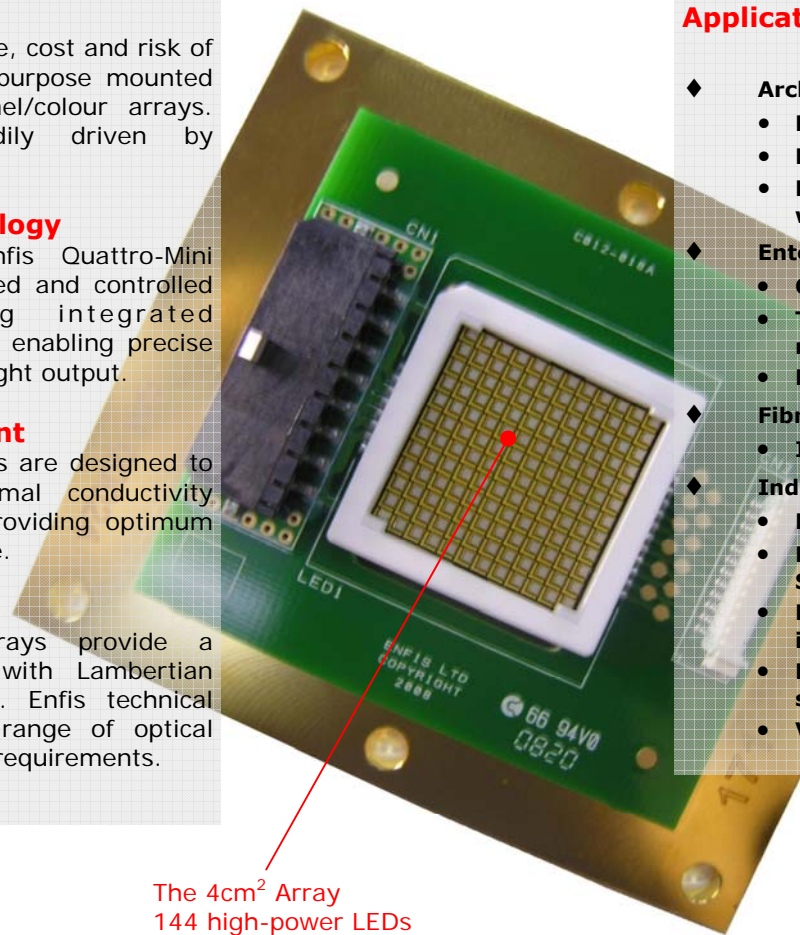

The 4cm<sup>2</sup> Array  
144 high-power LEDs

ENFIS LIMITED  
Technium 2, Kings Road,  
Swansea Waterfront,  
Swansea, SA18PJ, UK  
Tel +44 (0)1792 485660  
Fax +44 (0)1792 485537  
www.enfis.com  
info@enfis.com





# ENFIS QUATTRO Mini Array Green 520nm

## Technical Specification

### Electro-Optical Characteristics

Channel Item	Single Channel			All Channels		
	Min	Typ	Max	Min	Typ	Max
Rated Current If (mA)		1760			7040	
Forward Voltage Vf (Volts)	24	28	32	24	28	32
Peak Wavelength $\lambda_p$ (nm)	510	520	530	510	520	530
Dominant Wavelength $\lambda_d$ (nm)	518	528	538	518	528	538
Spectral Width $\Delta\lambda$ (nm)	32	37	42	32	37	42
Total Radiant Flux $\Phi_R$ (mW)	2350	2800		7500	9000	
Radiant Flux Density $\Phi_R/A$ (mW/cm <sup>2</sup> )	486	579		1550	1860	
Total Luminous Flux $\Phi_L$ (Lumens)	1000	1250		3300	4000	
Luminous Flux Density $\Phi_L/A$ (lm/cm <sup>2</sup> )	207	258		682	826	
Total Electrical Power P (W)		50			200	

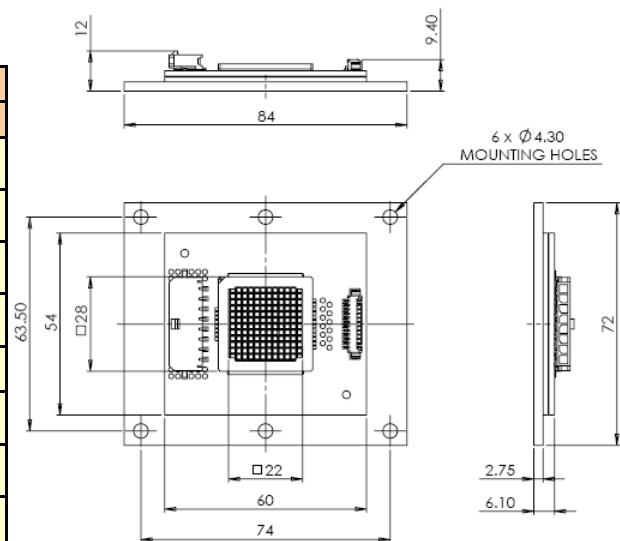

All measurements performed at a heatsink temperature of 25°C

LUMINOUS FLUX GRAPH

RADIANT FLUX GRAPH

IV GRAPH

Single Channel Data

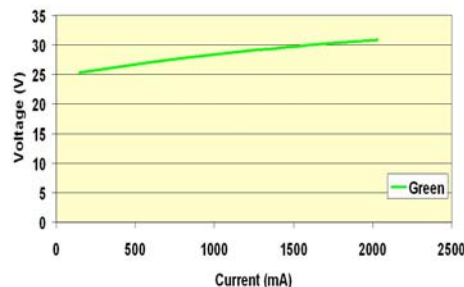
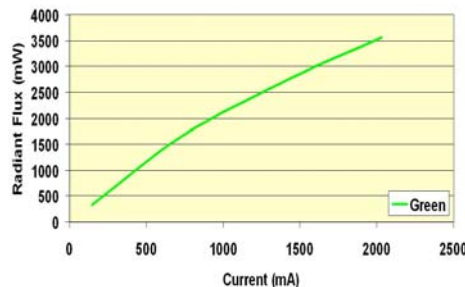
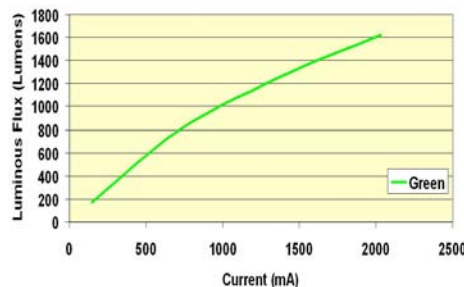

#### Storage Regime

Storage Temperature -20°C to +85°C

#### Weight

Array 0.2kg

#### Heat Generation

Proper thermal design of the end product is of paramount importance. The operational junction temperature of each LED chip should be kept below 125°C.

Please contact Enfis for further support in this matter.

#### Connector Types (not supplied)

Drive Molex 0436500812

Thermistor / Feedback Molex 532611271

#### Cleaning

Avoid touching the LED array surface.

To clean—BLOW surface with either dry air or nitrogen gas

#### Eye Safety Precautions

The light output of the products may cause injuries to human eyes in circumstances where the products are viewed directly with unshielded eyes for more than a few seconds.

Please refer to IEC 60825-1:2001 for further information



ENFIS LIMITED  
 Technium 2, Kings Road,  
 Swansea Waterfront,  
 Swansea, SA18PJ, UK  
 Tel +44 (0)1792 485660  
 Fax +44 (0)1792 485537  
 www.enfis.com  
 info@enfis.com

