

Features and Benefits

- Versatile A/D interface for resistive sensors
- ISO-15693 13.56MHz transponder
- Slave / Master SPI interface
- 4 k-bit EEPROM with access protection
- Standalone data-logging mode
- Ultra low power
- Battery or battery-less applications
- Low cost and compact design

Application Examples

- Cold chain monitoring
- Asset management and monitoring (security and integrity)
- Building automation
- Industrial, medical and residential control and monitoring

Ordering Information ⁽¹⁾

Part No.	Temperature suffix	Package Code	Option code
MLX90129	R (-40°C to 105°C)	GO [TSSOP 20]	-

⁽¹⁾ Example: MLX90129RGO

1 Functional Diagram

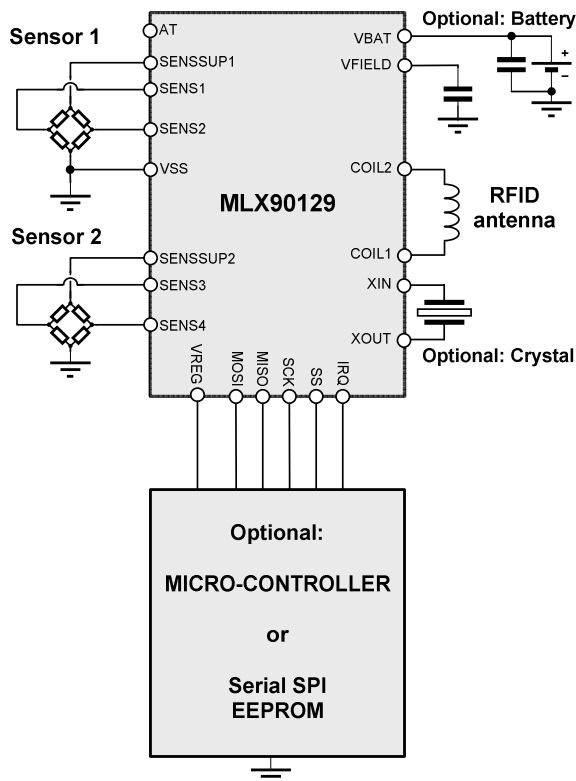

2 General Description

The MLX90129 combines a precise acquisition chain for external resistive sensors, with a wide range of interface possibilities.

It can be accessed and controlled through its ISO15693 RFID front-end or via its SPI port.

Without any other components than a 13,56MHz tuned antenna, it becomes a RFID thermometer.

For measuring other physical quantities, one or two resistive sensors can be connected to a make batteryless sensing point. Also, the chip can supply a regulated voltage to other components of the application.

Adding a battery will enable the use of the standalone data logging mode. The sensor output data is stored in the internal 3.5kbits user memory. One can extend the storage capacity by connecting an external EEPROM to the SPI port.

The SPI port can also connect the MLX90129 to a microcontroller which allows more specific applications, like adding actuating capability or RF transmission.

The MLX90129 has been optimized for low power, low voltage battery and battery-less applications.

3 Glossary of Terms

EEPROM	Electrically Erasable Programmable Read-Only Memory
DMA	Direct Memory Access (It is the digital unit managing data-logging)
PGA	Programmable Gain Amplifier
LFO	Low Frequency Oscillator
XLFO	Crystal Low Frequency Oscillator
CTC	Contactless Tuning Capacitance
HFO	High Frequency Oscillator

4 Absolute Maximum Ratings

Parameter	Value	Unit
Supply Voltage, V_{BAT} (maximum rating)	5.5	V
Maximum Voltage on any Pin except VFIELD, COIL1 & COIL2	$V_{BAT} + 0.5$	V
Reverse Voltage Protection	-0.5	V
Maximum voltage on Pin VFIELD	6	V
Maximum voltage on Pin COIL1 & COIL2	7	V
Operating Temperature Range, T_A	-40 to +105	°C
Storage Temperature Range, T_S	150	°C
ESD Sensitivity (AEC Q100 002)*	4	kV

* All pin except Pin No 6 (VFIELD limited to 1,5kV) and Pin No 15 (SENSSUP2 limited to 3,5kV)

Exceeding the absolute maximum ratings may cause permanent damage.
Exposure to absolute-maximum-rated conditions for extended periods may affect the device's reliability.

5 Pin definition

	Pin	Symbol	I/O	Description
	1	COIL2	B	Coil terminal 2 for RFID interface
	2	COIL1	B	Coil terminal 1 for RFID interface
	3	VFIELD	O	Unregulated supply voltage (from RF field)
	4	VREG	O	Regulated supply voltage
	5	XIN	I	Crystal oscillator input 1
	6	XOUT	I	Crystal oscillator input 2
	7	AT	I	Anti Theft (to be connected to ground)
	8	IRQ	O	Interrupt output
	9	MISO	B	SPI Master In Slave Out
	10	MOSI	B	SPI Master Out Slave In
	11	SCK	B	SPI Serial Clock
	12	SS	B	SPI Slave Select
	13	SENS4	I	Sensor 2 input 2
	14	SENS3	I	Sensor 2 input 1
	15	SENSSUP2	O	Sensor 2 supply
	16	SENSSUP1	O	Sensor 1 supply
	17	SENS2	I	Sensor 1 input 2
	18	SENS1	I	Sensor 1 input 1
	19	VSS	I	Ground
	20	VBAT	I	Battery supply

TABLE OF CONTENT

1 Functional Diagram	1
2 General Description	1
3 Glossary of Terms	2
4 Absolute Maximum Ratings.....	2
5 Pin definition	2
6 General Electrical and Timing Specifications	4
6.1 Power consumption.....	4
6.2 RFID interface	4
6.3 SPI: electrical specification	4
6.4 Non-volatile memories.....	4
6.5 Slave SPI: timing specification.....	5
6.6 Master SPI timing specifications	6
6.7 Sensor Signal Conditioner: electrical specifications	6
6.8 VREG regulator, battery monitoring and Oscillators: electrical specifications.....	8
7 General Description.....	9
7.1 Block diagram	9
7.2 Digital Controller and memory domains.....	10
7.2.1 Digital controller	10
7.2.2 Address domains	10
7.3 Internal Devices.....	12
7.3.1 EE-Latches	13
7.3.2 Sensors ADC buffers	14
7.4 Configuration EEPROM & Register files	14
7.4.1 EEPROM Map	14
7.4.2 Update of the Register File.....	15
7.5 EE-Latches and EEPROM Melexis default configuration	16
8 Communication.....	17
8.1 RFID communication.....	17
8.1.1 RFID analog front-end.....	17
8.1.2 ISO-15693 Features and Command set.....	17
8.1.3 Internal Devices dedicated to RFID communication	25
8.2 Serial Peripheral Interface (SPI)	27
8.2.1 SPI : modes of operation	27
8.2.2 Slave SPI command set.....	27
8.2.3 Internal devices dedicated to SPI communication	28
8.3 Management of communication conflicts	31
9 Device Configuration	32
9.1 Standalone datalogger	32
9.1.1 Main features	32
9.1.2 DMA operations	32
9.1.3 Setup of the Automatic Logging Mode.....	34
9.1.4 Direct Memory Access configuration	35
9.1.5 Wake-up timer / Power management configuration	36
9.1.6 Master SPI configuration	37
9.2 Sensor Signal Conditioner.....	38
9.2.1 Block description.....	38
9.2.2 Sensors common configuration	42
9.2.3 Sensor specific configuration	44
9.3 Power management	47
9.3.1 Power modes	47
9.3.2 Oscillators management	48
9.3.3 Energy scavenging	48
9.4 Security	49
9.4.1 Communication security	49
9.4.2 EEPROM Access security.....	49
10 Application Information.....	51
11 Reliability Information	53
12 ESD Precautions	53
13 Package Information	54
14 Disclaimer.....	55

6 General Electrical and Timing Specifications

DC Operating Parameters $T_A = -40^{\circ}\text{C}$ to 105°C , $V_{\text{BAT}}=4\text{V}$ (unless otherwise specified)

6.1 Power consumption

DC Operating Conditions ($T = -40^{\circ}\text{C}$ to 105°C , $V_{\text{VREG}} = 2.0\text{V}$ to 3.2V)

Parameter	Conditions	Min	Typ	Max	Unit
Current consumption in "Stand-by" mode		-	0.5*	14**	μA
Current consumption in "Sleep" mode	Using the RC-oscillator Using external oscillator	-	1.5* 2*	15**	μA
Current consumption in "Watchful" mode		-	100*	-	μA
Current consumption in "Run" mode	EEPROM writing Sense & Convert	- 300*	80* 500*	- 600*	μA μA

* at 25°C

**at 105°C

6.2 RFID interface

DC Operating Conditions ($T = -40^{\circ}\text{C}$ to 105°C)

Parameter	Conditions	Min	Typ	Max	Unit
Programmable resonance capacitance	Once trimmed	73	75	77	pF
Minimum coil AC voltage (for operation)			3		V_{peak}
Maximum voltage on Coil1, Coil2	Induce voltage on VFIELD is below 6V			7	V_{pp}
ISO/IEC 15693-3 data rate			26		kbits/s
Vfield external Capacitor			100		nF

6.3 SPI: electrical specification

DC Operating Conditions ($T = -40^{\circ}\text{C}$ to 105°C) and Lo w-volt option not activated

Parameter	Description	Min	Typ	Max	unit
VIH	Input High Voltage (SPI slave)	2.1	3.0	3.5	V
VIL	Input Low Voltage (SPI slave)	-0.3	0	0.9	V
VOH	Output High Voltage (I sunk = -2 mA)	2.2		-	V
VOL	Output Low Voltage (I forced = 2 mA)	-		0.4	V

DC Operating Conditions ($T = -40^{\circ}\text{C}$ to 105°C) and Lo w-volt option activated

Parameter	Description	Min	Typ	Max	unit
VIH	Input High Voltage (SPI slave)	1.4	2.0	2.5	V
VIL	Input Low Voltage (SPI slave)	-0.3	0	0.6	V
VOH	Output High Voltage (I sunk = -2 mA)	1.2		-	V
VOL	Output Low Voltage (I forced = 2 mA)	-		0.4	V

6.4 Non-volatile memories

Parameter	Description	Min	Typ	Max	unit
DataRet85	Data retention at 85°C	10			year
Cyclenb25	Number of program cycles at 25°C	100000			-
Cyclenb125	Number of program cycles at 125°C	10000			-

6.5 Slave SPI: timing specification

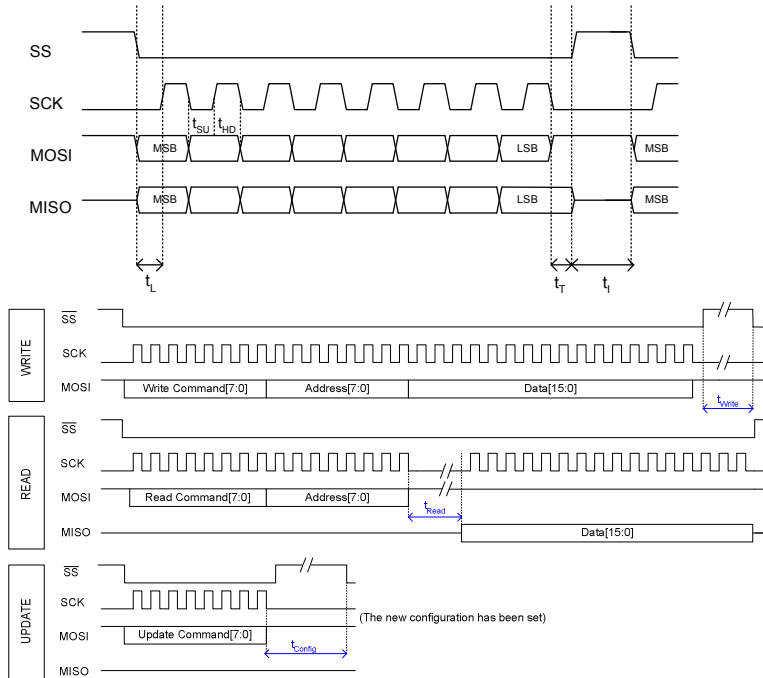

Timing specifications

Parameter	Description	Slave side		Units
		Min	Max	
t_{ch}	SCK high time	500	-	ns
t_{cl}	SCK low time	500	-	ns
$t_{Read}^{(**)}$	Delay to read a register word Delay to read an EEPROM word Delay to read an EE-Latch word Delay to get the ADC output code	2 50 2 2300	- - - (*)	μ s
$t_{Write}^{(**)}$	Delay to write a register word Delay to write an EEPROM word Delay to write an EE-Latch word	- 17 11	- - -	ms
t_{Config}	Execution delay for commands <i>Update</i>	1.5	-	ms
t_{SU}	Setup time of data, after a falling edge of SCK	100	-	ns
t_{HD}	Hold time of data, after a rising edge of SCK	500	-	ns
t_L	Leading time before the first SCK edge (in clock pulses) _ when the MLX90129 is not in sleep mode _ when the MLX90129 is in sleep mode (***)	600 1.5	- -	ns ms
t_T	Trailing time after the last SCK edge	500	-	ns
t_I	Idling time between transfers (SS=1 time)	500	-	ns

(*) – The conversion time depends on the programmed initialization time and on the ADC options.

(**) For the Read/Write Internal Devices commands, the delay depends on the nature of the so-called Internal Device: (Register, EE-Latch bank, ADC,...)

(***) – See the power management chapter to know when the MLX90129 may be in sleep mode

6.6 Master SPI timing specifications

Parameter	Description	Master side			Units
		Min	Nom	Max	
tch	SCK high time		400		ns
tcl	SCK low time		400		ns
t _{Read}	Read EEPROM time		0.4		µs
t _{Write}	Erase or Write EEPROM time	1		28	ms
t _{SU}	Setup time of data, after a falling edge of SCK		400		ns
t _{HD}	Hold time of data, after a rising edge of SCK		400		ns
t _L	Leading time before the first SCK edge		400		µs
t _T	Trailing time after the last SCK edge		400		ns
t _i	Idling time between transfers (SS=1 time)		1600		ns

6.7 Sensor Signal Conditioner: electrical specifications

-40°C < Temp < 105°C, unless otherwise specified. The sensor is supplied by a regulated voltage called V_{ref}.

Parameter	Symbol	Conditions / Comment	Min	Typ	Max	Units
GENERAL CHARACTERISTICS						
Battery voltage	Vbat	Low-volt option deactivated	3.8		5.5	V
		Low-volt option activated	2.9		5.5	V
SENSOR ADJUSTMENT CAPABILITY						
Reference voltage V _{ref} (²)	Sens_Vref	Low-volt option = 0	3.0	3.1	3.2	V
		Low-volt option = 1	2.0	2.1	2.2	V
Full Span (³)	Sens_FS	Full scale of the sensor output voltage (Sens_CM is at the specified value)	V _{ref} / 1200	-	V _{ref} / 16	V
Zero offset (¹)(³)	Sens_Off	Maximum sensor offset that can be compensated	- V _{ref} / 32	-	+ V _{ref} / 32	V
Common-mode voltage	Sens_CM		1/3 * V _{ref}	1/2 * V _{ref}	2/3 * V _{ref}	V
SENSSUP1 output impedance	Sens1_Z			7		Ω
SENSSUP2 output impedance	Sens2_Z			15		Ω

Notes:

(¹): The capability of adjustment of the input offset depends on the selected gain of the first Programmable Gain Amplifier (PGA1) and on the sensor output span.

(²): The reference voltages of the ADC, of the DAC and the supply voltage of the sensors are ratio-metric.

(³): Full span is defined as the maximal sensor differential output voltage: $\Delta V(\text{sensor output})_{\text{max}}$, i.e the maximum voltage range allowed on the 90129 sensor interface inputs SENS1, SENS2, SENS3 and SENS4.

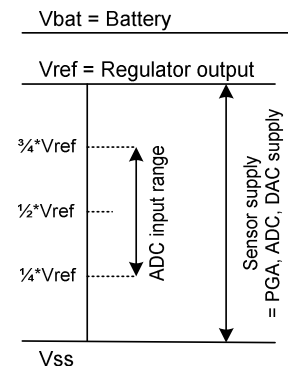

Parameter	Symbol	Conditions / Comment	Min	Typ	Max	Units
PROGRAMMABLE-GAIN AMPLIFIER PGA1						
Gain accuracy	PGA1_Accu	Code PGA1gain[3:0] = 0000 (gain=8) -> 1010 (gain=75)	90	100	110	%typ
PROGRAMMABLE-GAIN AMPLIFIER PGA2						
Gain accuracy	PGA2_Gain	Code PGA2gain[2:0] = 000 (gain=1) -> 111 (gain=8)	90	100	110	%typ
PGA1 + PGA2 + DAC						
Gain range	PGA_Gain		8		600	V/V
Sensor offset trimming range	PGA_Off_R	(= offset max of the sensor)	$-V_{ref}/32$		$+V_{ref}/32$	V
Sensor offset trimming step	PGA_Off_S	8-bits DAC (7 bits + sign) Ratio-metric, to cancel the offset of the sensor		$V_{ref}/128$		V
Differential input range	PGA_Dir	Gain (PGA) = 8 (if higher, PGA_Dir should be $V_{ref}/2$ divided by the gain)		$V_{ref}/16$		V
ADC differential input range	ADC_Dir			$\frac{1}{2} \cdot V_{ref}$		V
DAC (differential outputs)						
Resolution	Dac_Res	7 bits + 1 bit sign		8		bit
INL	Dac_Inl		0		0.5	lsb
DNL	Dac_Dnl		0		0.5	lsb

Parameter	Symbol	Conditions / Comment	Min	Typ	Max	Units
BRIDGE SUPPLIES & REFERENCES						
Reference serial resistance	Ref_Res	6 bits-programmable: Min Max		0.4 65		k Ω
Serial resistance step	Ref_Step			1.1		k Ω
INTERNAL TEMPERATURE SENSOR						
Full scale	ITS_FS		-40		+105	$^{\circ}\text{C}$
Output range	ITS_Or	$\Delta\text{Temp} = 145^{\circ}\text{C}$, $V_{ref}=3.1\text{V}$	-	125	-	mV
Offset	ITS_Off	ΔV_{out} at $T = 20^{\circ}\text{C}$, $V_{ref}=3.1\text{V}$		25		mV
Sensitivity	ITS_Sens	$\Delta V_{out} / \Delta\text{Temp}$, $V_{ref}=3.1\text{V}$	-	0.86	-	mV/ $^{\circ}$
Non-linearity	ITS_LinErr	$\Delta\text{Temp} = 145^{\circ}\text{C}$, $V_{ref}=3.1\text{V}$	-	± 0.9	-	mV

ADC

The *MODE[1:0]* bits controls the tradeoff between the duration of the counting phase and the resolution. Mode 00 is the fastest but also the least accurate mode whereas the mode 11 is the most accurate but the slowest. The *LOW_POWER* bit allows the user to reduce the power consumption of the analog

ADC parameter	Mode 00	Mode 01	Mode 10	Mode 11	Units
ENOB: effective number of bits	8	9	10	11	bit
Conversion time (*) in normal power mode	2.1	4.2	8.3	16.5	ms
Conversion time (*) in low power mode	4.2	8.4	16.6	33	

(*): To get the sampling rate of the system, the initialization time must be added to the conversion time. This time is programmable as it depends on the selected sensor (by default it is 150 μ s).

6.8 VREG regulator, battery monitoring and Oscillators: electrical specifications

-40°C < Temp < 105°C, unless otherwise specified.

Parameter	Symbol	Conditions / Comment	Min	Typ	Max	UNITS
VREG REGULATOR						
Output voltage	Vreg_Vhigh	Low-volt option = 0	2.8	3.0	3.2	V
	Vreg_Vlow	Low-volt option = 1	2.0	2.2	2.4	V
Output max. current	Vreg_I _{max}	Low-volt option			2.0	mA
		Drop 7% VREG Drop 17% VREG			5.0	mA
External capacitor	Vreg_Capa	Stable smoothed signal	0	-	10	μ F

BATTERY LEVEL MONITOR CIRCUIT						
Threshold	Bmc_Thres	At 25 °C	1.1	1.9	2.5	V

OSCILLATORS						
Internal Low Frequency Oscillator	f _{LFO}	Factory calibration		32,768		kHz
Accuracy of the LFO frequency	A _{CLFO}			±15		%
Crystal Frequency Oscillator	f _{XLFO}	With an external 32,768kHz crystal		32,768		kHz

7 General Description

7.1 Block diagram

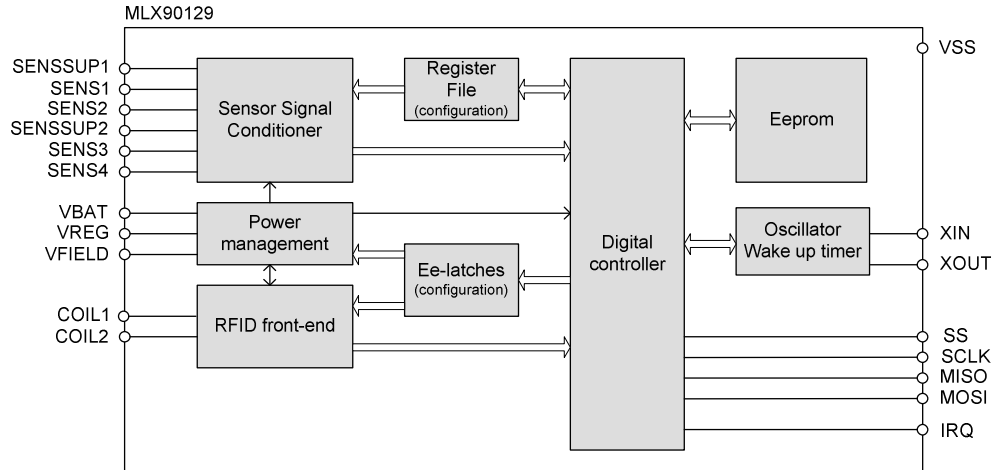

The **sensor signal conditioner** is used to amplify, filter and convert the output voltage of resistive sensors. There may be an external single-ended or differential resistive sensor, or the internal temperature sensor. The two external sensors are supplied by a stable reference voltage, provided by an integrated voltage regulator. The sensor output voltage is amplified thanks to a programmable-gain amplifier, and has its offset voltage compensated. Then, the conditioned sensor signal fits the input range of the A/D converter. The ADC converts the signal in a 16-bits code that can be stored or transmitted.

The **power management** unit deals with the different power modes of the chip: it monitors the battery level, scavenges the energy coming from a RFID 13,56MHz field and makes the power-on reset signal. A regulator is used to supply the digital parts, but can also be used to supply some other external devices.

The **Oscillators' block** contains different kinds of oscillators: a very low power, low frequency 1kHz RC oscillator used as a wake-up timer, a low-power 32.768kHz quartz oscillator that can be used for an accurate time basis, and a high frequency 5MHz RC oscillator used for the digital controller.

The **Register File** contains all the configuration parameters of the chip. It may be loaded from the EEPROM after power-on, or as the result of a specific request from RFID or SPI.

The **EE-Latches** are used when device configuration parameters have to be immediately available.

The **RFID front-end** receives an external 13,56-MHz magnetic field, sensed on an external antenna coil. The antenna design is made easy thanks to an internal programmable high-Q capacitance (tuned during the test phase). From the antenna output voltage, it makes a stable clamped DC supply voltage, recovers the clock, and controls the modulation of the carrier and the demodulation of the incoming signal.

The **EEPROM** is a 4-kbits non-volatile memory, organized as 256 words of 16 bits divided in 39 reserved for configuration, 2 for default trimming value (*EE-Latches #03, #04 and #09*) backup and 215 available for the application (around 3.4 kbits user memory). Its access is protected by several security levels. Some *EE-Latches* are also used when the stored data have to be immediately available for use.

The **Digital Controller** manages the accesses of the different interfaces (SPI, RFID) with the different memories (EEPROM, register file) and the sensor. It comprises the RFID ISO-15693 and SPI protocols, controls the sensor signal conditioner and stores or sends the ADC output code. It can also run some standalone applications, thanks to its unit called *Direct Memory Access (DMA)*.

7.2 Digital Controller and memory domains

7.2.1 Digital controller

The main features of the digital part of MLX90129, called *Digital Controller* are:

- Slave / Master SPI interface
- RFID interface
- DMA: Direct Memory Access
- Register File controller
- EEPROM controller
- Sensor interface controller
- Clock and Power management
- Core: transactions arbiter and interrupt manager

The digital controller manages the transactions between the communication interfaces, the memories and the sensor. It allows also a standalone mode with its DMA unit. All these blocks are described in the next chapters.

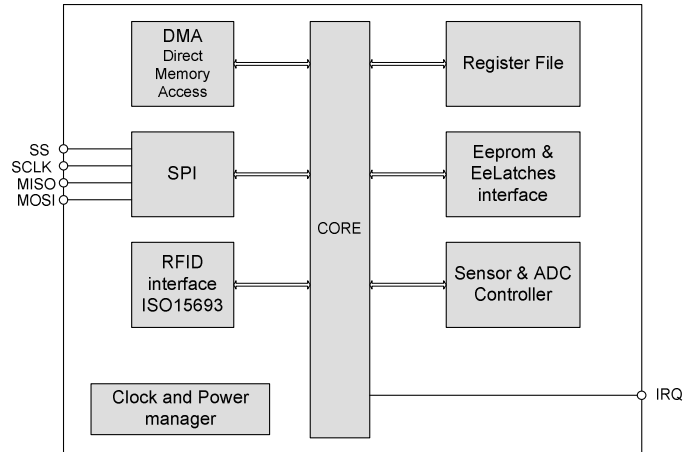

The SPI and RFID communication ways can be used concurrently. The *Core transaction arbiter* handles the priorities and the interrupts. It updates some status bits that may be used by the external microcontroller or the RFID base-station to optimize the communication.

The *Digital Controller* of the MLX90129 allows the user to do the following tasks, via SPI or RFID:

- _ Configure the sensor interface and the communication media.
- _ Manage the power consumption, the interrupts, the security items,...
- _ Run A/D conversions of the selected sensors.
- _ Store (or read) data in the internal or in an external EEPROM.
- _ Configure and start a standalone process (sleep – sense – interrupt or store – sleep - ...)
- _ Get the status of the current process.

All these tasks may be done by simply reading or writing the different memories: EEPROM, registers, ee-Latches, internal devices. Thus, several address domains are defined to access them in an easy way.

7.2.2 Address domains

Four address domains have been defined to designate the memory and the non-memory devices that act during the requested transactions:

- **EEPROM address domain:**

This domain addresses the non-volatile EEPROM. It is used to store the user-defined data and the image of the *Register File* that can be automatically downloaded after a power-on. This memory block is energy independent and can store data even when the MLX90129 is no longer powered.

- **Register File address domain:**

This memory domain is used to store the current configuration information of all internal MLX90129 devices (Sensor interface, Power management ...). This memory is energy-dependent and must be updated each time the MLX90129 is turned-on.

- Internal Devices address domain:

This domain allows accessing the registers linked to the so-called *internal devices* like the ADC buffers, the status words of the *Core Transaction Arbiter* and the EE-Latches. They may be accessed with the appropriate SPI / RFID commands including its address. The difference with the Register File is the fact that they are not copied from the EEPROM at the start-up and they may be used during the requested transaction.

- External memory address domain:

This domain addresses the external memory which can be connected to the MLX90129, using the SPI in master mode.

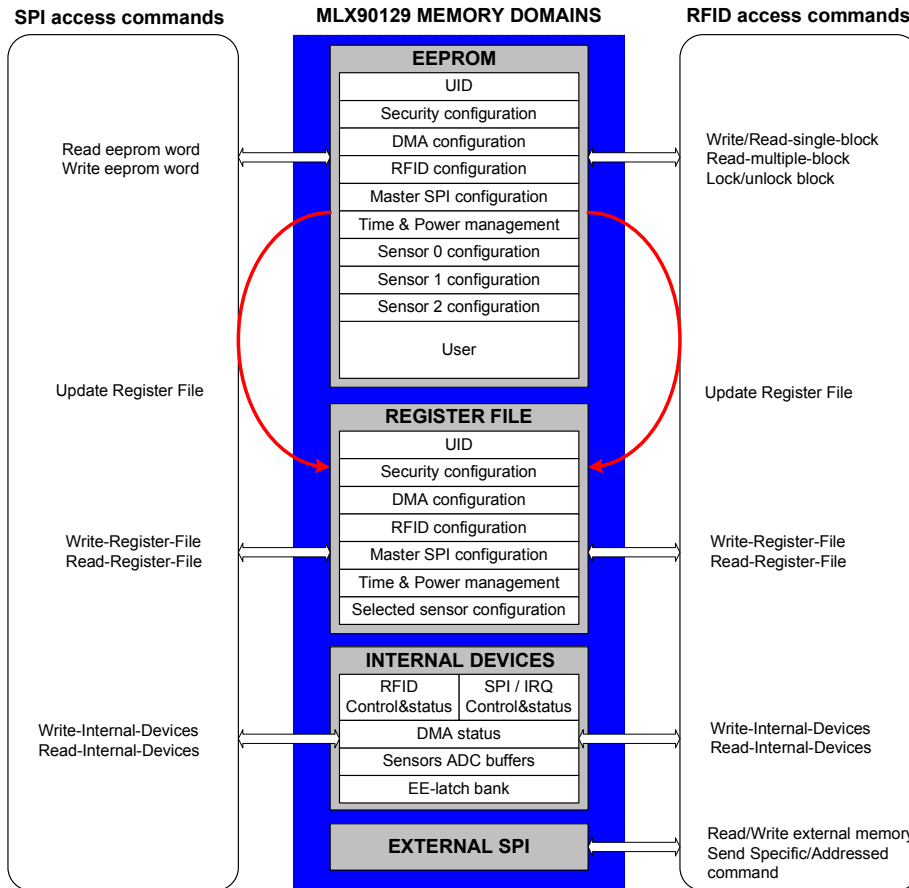

7.3 Internal Devices

The term *Internal Devices* designates the registers used to configure the main “non-memory” digital units: sensor interface, SPI / RFID interfaces, DMA ... All these registers are part of the *Internal Device Address Domain*:

The registers linked to the SPI and RFID interfaces, called *SPI/RFID core control word* and *SPI/RFID core interrupt/status word* have the same definition, but are physically different and may contain some different data. The content of these registers are explained in the following chapters (SPI, RFID). Some of these bits may be used to avoid conflicts for the memories access, when communicating with SPI and RFID at the same time. For that, they can be accessed at any time via SPI or RFID.

The SPI / RFID local buffers store the result data of the last transaction. They are useful for example when the A/D conversion time is too long and does not fit the timing requirements of the RFID protocol.

The *EE-Latches* and the *Contactless-tuning capacitance* code contain some non-volatile data, immediately available (no delay, no supply), used for the RFID capacitance trimming or for the options of the power management.

The registers of the DMA unit called *Current destination address* are used to give a status of the process (the number of words that have been registered).

The content of the *ADC buffer* depends on the selection byte (Address) used within the *Read/Write Device* command: it may be the data from the internal temperature sensor, or from one of the two external sensors. After receiving a *Read Device* command (from RFID or SPI, with the appropriate address), the MLX90129 supplies the selected sensor and its interface, converts its output in a digital format, and stores it in the appropriate *ADC Buffer*. The data is also available in the SPI / RFID local buffer.

The CTC is the code used to program the RFID antenna capacitance, according to the specifications.

Map of the *Internal Device Address Domain*

Addr	From SPI side	From RFID side	Link
SPI / RFID			
0x00	SPI core control word	RFID core control word	Page 28 / 25
0x01	SPI core interrupt/status word (read only)	RFID core interrupt/status word (read only)	Page 28 / 25
0x02	SPI local buffer (read only)	RFID local buffer (read only)	Page 28 / 25
Access by SPI and RFID			
Non-volatile memory			
0x03	EE-Latches word 0		Page 13 / 48
0x04	EE-Latches word 1		Page 13 / 47
Direct Memory Access (DMA)			
0x05	Current destination address (read only)		Page 35
Sensors			
0x06	ADC buffer sensor 0		Page 14
0x07	ADC buffer sensor 1		Page 14
0x08	ADC buffer sensor 2		Page 14
Contactless-tuning capacitance (CTC)			
0x09	CTC code		Page 13

Note:

The *internal devices* having the addresses 0x00, 0x01, 0x02, 0x05 are registers. Those having the addresses 0x03, 0x04, 0x09 are EE-Latches, and those whose addresses are 0x06, 0x07, and 0x08 refer to the ADC output buffers. The read / write delays are specified for all kind of *internal devices*, when accessing them via SPI.

7.3.1 EE-Latches

Another kind of non-volatile memory is used to store the trimming / configuration bits that should be immediately available: the EE-Latch bank. They are mainly used for the trimming of the oscillators and the capacitance of the antenna, for security and power management. It is important to read its value before re-programming it, in order to not erase some trimming bits.

EE-Latches map: (*Internal Devices Domain, Address #03, #04 and #09, read/write*)

Bits	Name	Description (when the bit is asserted high)
#03 - EE-Latches word 0		
4:0	LFO_Freq_Trim (Trimming bits)	(used by Melexis)
6:5	Bias_Cur_Trim (Trimming bits)	(used by Melexis)
7	DisableAutoLoading	Disables the automatic loading of the Register File with its image from the EEPROM after a power-on reset from the battery
10:8	HFO_Freq_Trim (Trimming bits)	(used by Melexis)
13:11	VReg_Trim (Trimming bits)	(used by Melexis)
14	RCb_Quartz	Selects the low-frequency RC-oscillator LFO (=0) or the quartz-oscillator XLFO (=1)
15	Disconnect_Vfield_Vbat	Disconnects the pads VFIELD and VBAT, when not using the energy from the field to supply the whole device.
#04 - EE-Latches word 1		
1:0	Mod_Res	11: default modulator resistance
2	VReg_Dis	Disables the VReg regulator and shorts-cut its output to Vbat
3	VReg_LV	Low-voltage option for the VREG regulator and the sensor regulator
7:4	Reserved	(Must be 0)
14:8	RFID_EEPROM_Lock_Map**	Map of pages in EEPROM, to be locked for RFID write, using the "Lock" command
15	RFID_Device_Lock**	Locks the RFID device
#09 - CTC code		
4:0	CTC_Trimming	Trimming of the integrated capacitance, part of the RFID antenna
15:5	Not used	(Must be 0)

(**) - following fields are not accessible for write from RFID interface via device write command.

EE-Latches backup in EEPROM

The content of EE-Latches (Internal devices #03, #04 and #09) are copied in the EEPROM for backup:

EEPROM #27 and #28

Bits	Description
#27 - Internal device backup word 1	
15:0	Copy of internal device #03 bits [15:0]
#28 - Internal device backup word 2	
3:0	Copy of internal device #04 bits [3:0]
15:4	random

7.3.2 Sensors ADC buffers

In order to read the output data of a sensor, the SPI master or the RFID base-station has to access one of the 3 words *ADC buffer* in the *Internal Device address domain*. Accessing (read command) this buffer makes:

- Load the selected sensor configuration into the register file
- Start the A/D conversion and the data processing.

Ex: The command read ADC buffer sensor 0 (Read Internal Device #06) sent by RFID or by SPI loads the configuration of the sensor 0 from EEPROM (address #15 to #1A) into the register file and start the A/D conversion. Then the command read ADC buffer sensor 2 (Read Internal Device #08) sent by RFID or by SPI overwrite the register file with the configuration of the sensor 2 (EEPROM from #21 to #26).

To make sure that all operations are done, it is enough to:

- Wait for a specific period of time and read the *internal device #02* (local buffer).
- Periodically monitor the *SPI/RFID Core status word* and check the bit: *Sensor interrupt: Data ready*.

Using RFID, it is usually needed to read *internal device #02* to access the ADC data.

7.4 Configuration EEPROM & Register files

The MLX90129 embeds a 4kbits EEPROM memory and some EE-Latches bits. This non-volatile memory contains the configuration parameters and some identification numbers. The configuration part of the EEPROM consists of 45 words of 16 bits. The 210 other words are available for the specific needs of the application or may be used for data-logging or for the configuration of the external devices. The read and write access rights are defined for each page and depends on the device wanting to access it: a microcontroller, a RFID base-station or the internal DMA unit of the MLX90129. The user can also lock and unlock some pages by sending the appropriate RFID commands.

7.4.1 EEPROM Map

Address	Description	Link
UID (Unique Identifier)		
#00	UID: bits 15:0	Page 17
#01	UID: bits 31:16	Page 17
#02	UID: bits 47:32	Page 17
#03	UID: bits 63:48	Page 17
Security configuration space		
#04	EEPROM security map	Page 49
#05	Device security map	Page 49
#06	Password RFID	Page 49
#07	(not used)	
#08	(not used)	
DMA configuration space		
#09	DMA: Control word	Page 35
#0A	DMA: Source address word	Page 35
#0B	DMA: Destination address word	Page 35
#0C	DMA: Length	Page 35
SPI (External memory) configuration space		
#0D	External memory: Control word	Page 37
#0E	External memory: Command codes word	Page 37
Timer (power control) configuration space		
#0F	Timer: Period	Page 36
#10	Timer: control word	Page 36
Address space always accessible from RFID interface		
#11	RFID user register: its purpose is user-defined.	Page 17

Address	Description	
Sensors common configuration space		
#12	Sensor power configuration word	Page 42
#13	(reserved)	
#14	Sensor trimming and fault-detector configuration word	Page 42
Sensor 0 configuration space		
#15	<i>Sensor 0</i> : Sensor control word	Page 44
#16	<i>Sensor 0</i> : Sensor low threshold word	Page 44
#17	<i>Sensor 0</i> : Sensor high threshold word	Page 44
#18	<i>Sensor 0</i> : Sensor signal conditioner configuration word	Page 44
#19	<i>Sensor 0</i> : Sensor connections configuration word	Page 44
#1A	<i>Sensor 0</i> : Sensor resistance configuration word	Page 44
Sensor 1 configuration space		
#1B	<i>Sensor 1</i> : Sensor control word	Page 44
#1C	<i>Sensor 1</i> : Sensor low threshold word	Page 44
#1D	<i>Sensor 1</i> : Sensor high threshold word	Page 44
#1E	<i>Sensor 1</i> : Sensor signal conditioner configuration word	Page 44
#1F	<i>Sensor 1</i> : Sensor connections configuration word	Page 44
#20	<i>Sensor 1</i> : Sensor resistance configuration word	Page 44
Sensor 2 configuration space		
#21	<i>Sensor 2</i> : Sensor control word	Page 44
#22	<i>Sensor 2</i> : Sensor low threshold word	Page 44
#23	<i>Sensor 2</i> : Sensor high threshold word	Page 44
#24	<i>Sensor 2</i> : Sensor signal conditioner configuration word	Page 44
#25	<i>Sensor 2</i> : Sensor connections configuration word	Page 44
#26	<i>Sensor 2</i> : Sensor resistance configuration word	Page 44
EE-Latches backup space		
#27	Internal device backup word 1	Page 13
#28	Internal device backup word 2	Page 13

(**) In the register file, this configuration space is updated from the appropriate part of the *Extended sensor configuration space* at each access to one of the three sensors. This configuration space and all others with higher addresses are not updated during a *Register File Update* operation.

7.4.2 Update of the Register File

The EEPROM contains the initial image of the *Register File*. This image is copied after the power-on, upon a SPI / RFID *Update* request. The sensor configuration in the *Register File* depends on the currently selected sensor. The sensor is selected either manually by reading the ADC buffer corresponding or automatically during a standalone application.

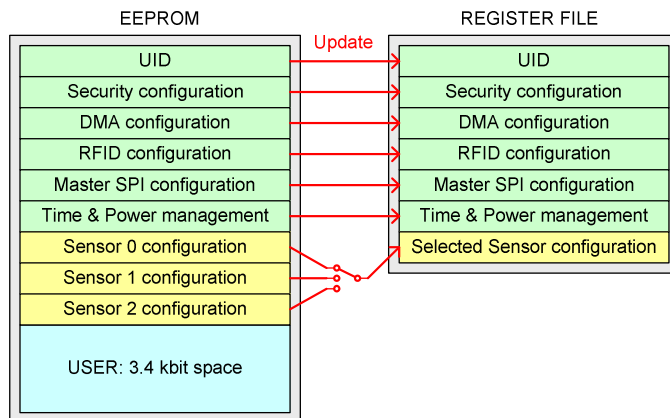

7.5 EE-Latches and EEPROM Melexis default configuration

The MLX90129 is pre-set with the following configuration.

Address	Default value	Description
EEPROM		
[#03 - #00]	0xXXXX	Unique ID set by Melexis
#04	0xAAA8	Refer to EEPROM security map
#05	0x3FF0	Refer to device security register
[#0B - #06]	0x0000	
#0C	0xXXXX	Random value, can be replaced by 0x0000
[#10 - #0D]	0x0000	
#11	0xXXXX	Random value, can be replaced by 0x0000
#12	0x00FF	Refer to sensor power configuration
#13	0x0000	
#14	0b0000.00TT.TT00.0000	
[#FF - #15]	0xXXXX	Random value, can be replaced by 0x0000
EE-Latches		
03	0b00TT.TTTT.0TTT.TTTT	Data loading enabled / LFO selected / Vfield connected to Vbat
04	0x000B	Low volt option =1
09	0b0000.0000.000T.TTTT	Reading gives 0x001F

'T' are Melexis trimming bits

In order to configure the registers of the MLX90129 easily, a configuration tool can be downloaded from the Melexis web site, www.melexis.com.

	A	B	C	D	E	F	G	H	I	J	K	L	M	N	O	P	Q	R	S	T
1	MLX90129 CONFIGURATION																			
2	update: 09/11/2009 rev 1.2																			
3	PRELIMINARY																			
4	: The Excel AddIns "Analysis ToolPak" need to be activated																			
5	Report error at rl@melexis.com																			
6	EEPROM CONFIGURATION (MLX90129 ES2)																			
7	Content	Address	Hex	15	14	13	12	11	10	9	8	7	6	5	4	3	2	1	0	Default Value
9	ID	01	0000	0	0	0	0	0	0	0	0	0	0	0	0	0	0	0	0	UID
10	ID	02	0000	0	0	0	0	0	0	0	0	0	0	0	0	0	0	0	0	UID
11	ID	03	0000	0	0	0	0	0	0	0	0	0	0	0	0	0	0	0	0	UID
12																				
13	Eeprom security	04	AAA8	1	0	1	0	1	0	1	0	1	0	1	0	1	0	0	0	0xAAA8
14	Device security	05	3FF0	0	0	1	1	1	1	1	1	1	1	1	1	0	0	0	0	0x3FF0
15	RFID password	06	0000	0	0	0	0	0	0	0	0	0	0	0	0	0	0	0	0	
16																				
17	DMA configuration	09	0078	0	0	0	0	0	0	0	0	0	0	0	1	1	0	0	0	
18	DMA source start address	0A	0000	0	0	0	0	0	0	0	0	0	0	0	0	0	0	0	0	
19	DMA destination start address	0B	0000	0	0	0	0	0	0	0	0	0	0	0	0	0	0	0	0	
20	DMA processing length	0C	0000	0	0	0	0	0	0	0	0	0	0	0	0	0	0	0	0	
21																				
22	SPI master configuration	0D	0000	0	0	0	0	0	0	0	0	0	0	0	0	0	0	0	0	
23	SPI master commands codes	0E	0000	0	0	0	0	0	0	0	0	0	0	0	0	0	0	0	0	
24																				
25	Times period	0F	0000	0	0	0	0	0	0	0	0	0	0	0	0	0	0	0	0	
26	Times control	10	0018	0	0	0	0	0	0	0	0	0	0	0	0	1	0	0	0	
27																				
28	RFID user register	11	0000	0	0	0	0	0	0	0	0	0	0	0	0	0	0	0	0	
29																				
30	Sensor power configuration	12	007F	0	0	0	0	0	0	0	0	1	1	1	1	1	1	1	1	0x00FF
31	Sensor trimming	14	0000	0	0	0	0	0	0	0	0	0	0	0	0	0	0	0	0	0b0000.00TT.TT00.0000
32																				
33	Sensor 0 control word	15	0000	0	0	0	0	0	0	0	0	0	0	0	0	0	0	0	0	
34	Sensor 0 low threshold	16	0000	0	0	0	0	0	0	0	0	0	0	0	0	0	0	0	0	
35	Sensor 0 high threshold	17	0000	0	0	0	0	0	0	0	0	0	0	0	0	0	0	0	0	
36	Sensor 0 conditioner config.	18	0000	0	0	0	0	0	0	0	0	0	0	0	0	0	0	0	0	
37	Sensor 0 connection config.	19	0000	0	0	0	0	0	0	0	0	0	0	0	0	0	0	0	0	
38	Sensor 0 resistance network	1A	0000	0	0	0	0	0	0	0	0	0	0	0	0	0	0	0	0	

8 Communication

8.1 RFID communication

8.1.1 RFID analog front-end

The MLX90129 RFID interface complies with the ISO-15693 requirements. It is accessed by the RFID base-station (reader) in modulating the 13.56 MHz carrier frequency. The data are recovered from the signal amplitude modulation (ASK, Amplitude Shift Keying 10% or 100%). The Data transfer rate is 26 kBit/s using the 1/4 pulse-coding mode.

The outgoing data are generated by an antenna load variation, using the Manchester coding, and using one or two sub-carrier frequencies at 423 kHz and 484 kHz. The data transfer rate is 26 k-Bit/s. From the incoming field, the RFID interface recovers the clock and makes its own power supply. The rectified voltage may also be used to supply the whole device in battery-less applications.

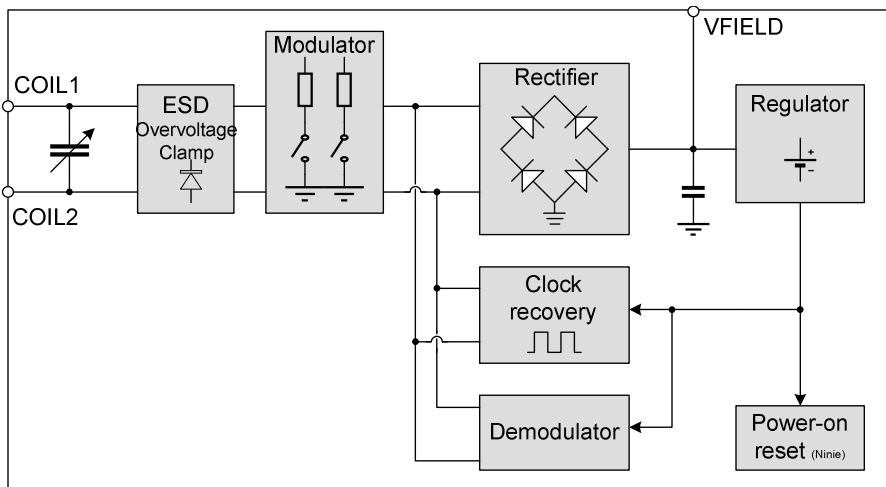

8.1.2 ISO-15693 Features and Command set

For complete information about the communication protocol, please refer to the standard document: ISO/IEC FCD 15693-2 and ISO/IEC FCD 15693-3: **Identification cards- contactless integrated circuit(s) cards - Vicinity cards** - It is available on the website: <http://www.iso.org>
 Some of the features of the protocol are not supported. Furthermore, some “custom” commands have been defined (see Command set). The MLX90129 is provided with a Unique IDentifier compliant with the ISO standard.

Summary of the main, supported features

Features	Supported	Not supported
Reader to Tag Modulation Index	10% and 100%	
Reader to Tag Coding	Pulse Position Modulation: 1 out of 4	PPM: 1 out of 256
Tag to Reader Modulation	Single and dual Sub-carrier	
Tag to Reader Sub-Carrier	423 kHz / 484 kHz	
Tag to Reader Coding	Manchester	
Tag to Reader Data-rate	High Data-rate 26 kBit	Low Data-rate 6 kBit

Summary of the main, supported protocol parts

- Data element

Data Element	Supported
UID (Unique Identifier)	Yes
AFI (Application Family Identifier)	No
DSFID (Data Storage Format Identifier)	No
CRC	Yes
Security status	No

- Protocol

Request Flag	Supported
Sub-Carriers	Yes
Data-rates	No
Inventory	Yes
Protocol extension	No
Select	Yes
Address	Yes
Options (write single block command only)	Yes
Response Flag	Supported
Error	Yes

- Anti-collision: Supported

Command frame

The content of the data included in the frame of a communication request, and the response from the MLX90129 to the base-station depends on the command opcode. The meaning of the flags, the equation of the CRC, the description of the Start-Of-Frame, the End-Of-Frame and the unique identifier number (UID), the meaning of the error codes... are included in the standard ISO-15693 layers 2 and 3.

Request format for ISO15693 commands:

SOF	Flags	Command code	(UID)	(Data)	CRC 16	EOF
	8 bits	8 bits	64 bits	x bits	16 bits	
	0XXX 0X1X (bin)	XX (hex)	Optional			

Request format for MLX90129 commands:

SOF	Flags	Command code	(UID)	(Data)	CRC 16	EOF
	8 bits	16 bits	64 bits	x bits	16 bits	
	00XX 0X1X (bin)	XX1F (hex)	Optional	Optional		

Response format without data when Error_flag is NOT set:

SOF	Flags	CRC 16	EOF
	8 bits	16 bits	
	0000 0000		

Response format with data when Error_flag is NOT set:

SOF	Flags	(Data)	CRC 16	EOF
	8 bits	x bits	16 bits	
	0000 0000			

Response format with error when Error_flag is set:

SOF	Flags	Error code	CRC 16	EOF
	8 bits	8 bits	16 bits	
	0000 0001			

Command set

The command set lists the mandatory commands defined in the standard ISO-15693 layer 3. It comprises also some custom commands used for some specific applications: access the sensor buffer, access an external device via SPI, handles the security options, etc.

ISO-15693 mandatory and optional commands

Commands	code	Description
Inventory	01	Enable an anti-collision sequence
Stay quiet	02	Enable the ' <i>Stay Quiet</i> ' mode
Read single block	20	Read a single word from EEPROM
Write single block	21	Write a single word to EEPROM (only mode with Option_flag set is supported)
Read multiple block	23	Read one or several contiguous blocks of the EEPROM
Select	25	Enter the "Selected" state (anti-collision)
Reset to ready	26	Return to the ' <i>Ready</i> ' mode

MLX90129 custom commands

Commands	code	Description
Read register file	A01F	Read one word from the <i>Register file</i>
Write register file	A11F	Write one word to the <i>Register file</i>
Read internal device	A21F	Read the content of an <i>internal device</i> identified by an address byte
Write internal device	A31F	Write the register word of an <i>internal device</i> , identified by an address byte
Read external memory	A41F	Read a word from an external memory (via SPI)
Write external memory	A51F	Write a word into an external memory (via SPI)
Send specific command	A61F	Send a command via SPI to an external device, whose code is appended to the frame (e.g. Write Enable for an external EEPROM).
Send addressed specific command	A71F	Send a command via SPI to an external device, whose code and address are appended to the frame (e.g. <i>Lock Block</i> for an external EEPROM)
Write external memory status	A81F	Send a command via SPI, to write an external memory status register (The op-code of this command is stored in a register)
Read external memory status	A91F	Send a command via SPI, to read an external memory status register (The op-code of this command is stored in a register)
Lock device	B01F	Lock an <i>internal device</i> (EEPROM, ADC, ...), preventing its access.
Unlock device	B11F	Unlock an <i>internal device</i>
Update Register File	C01F	Fill the <i>Register File</i> with the image from the EEPROM, without re-boot
Lock Page	D01F	Lock a page of EEPROM
Unlock Page	D11F	Unlock a locked page of EEPROM.

0x1F corresponds to the RFID manufacturer code of Melexis

ISO-15693 mandatory and optional commands frame content

- **INVENTORY (01)**

When receiving the Inventory request, the transponder shall perform the anti-collision sequence. The Inventory flag shall be set to 1.

Request format:

S	Flags	Inventory command	Mask length	Mask value	CRC 16	E
O	8 bits	8 bits	8 bits	0 - 64 bits	16 bits	O
F	00x0 011x	0000 0001				F

Response format (if no error):

S	Flags	DSFID	UID	CRC 16	E
O	8 bits	8 bits	64 bits	16 bits	O
F	0000 0000	0000 0000			F

- **STAY QUIET (02)**

When receiving the Stay Quiet command, the transponder shall enter the Quiet state and shall not send back a response. This command shall always be executed in Addressed mode (Select flag=0 and Address flag= 1)

Request format:

S	Flags	Stay Quiet command	UID	CRC 16	E
O	8 bits	8 bits	64 bits	16 bits	O
F	001x 001x	0000 0010			F

- **READ SINGLE BLOCK (20)**

When receiving the Read single block request, the transponder shall read the requested block from internal EEPROM and send back its value in the response.

Request format:

S	Flags	Read Single Block	UID	Block address	CRC 16	E
O	8 bits	8 bits	64 bits	8 bits	16 bits	O
F	00x0 011x	0010 0000	(Optional)			F

Response format (if no error):

S	Flags	Data	CRC 16	E
O	8 bits	16 bits	16 bits	O
F	0000 0000			F

- **WRITE SINGLE BLOCK (21)**

When receiving the "Write Single Block" request, the transponder shall write the requested block into internal EEPROM with the data contained in the request and report the success of the operation in the response. Only the mode with Option_flag set is supported. That means, the MLX90129 shall wait for the reception of an end of frame (EOF) from the ISO15693 reader and upon such reception shall return its response.

Request format:

S	Flags	Read Single Block	UID	Block address	Data	CRC 16	E
O	8 bits	8 bits	64 bits	8 bits	16 bits	16 bits	O
F	01xx 001x	0010 0001	(Optional)				F

- **READ MULTIPLE BLOCKS (23)**

When receiving the “Read Multiple Block” command, the transponder shall read the requested block(s) and send back their value in the response. The blocks are numbered from ‘00’ to ‘FF’. The number of blocks in the request is one less than the number of blocks that the 90129 shall return in its response.

Request format:

S	Flags	Read Multiple Block	UID	First block address	Number of blocks	CRC 16	E
O	8 bits	8 bits	64 bits	8 bits	8 bits	16 bits	O
F	00xx 001x	0010 0011	(Optional)		N		F

Response format (if no error):

S	Flags	Data	CRC 16	E
O	8 bits	(N+1)*16 bits	16 bits	O
F	0000 0000			F

- **SELECT (25)**

When receiving the Select command:

_ if the UID is equal to its own UID, the 90129 shall enter the selected state and shall send a response.

_ if it is different, the 90129 shall stay at previous state and shall not send a response. The Select command must be always in Addressed mode. (The Select_flag is set to 0. The Address_flag is set to 1.)

Request format:

S	Flags	Read Single Block	UID	CRC 16	E
O	8 bits	8 bits	64 bits	16 bits	O
F	0010 001x	0010 0101			F

- **RESET TO READY (26)**

When receiving the Reset To Ready command, the transponder shall return to the Ready state

Request format:

S	Flags	Reset to ready	UID	CRC 16	E
O	8 bits	8 bits	64 bits	16 bits	O
F	01xx 001x	0010 0110			F

MLX90129 custom commands frame contents

- **READ REGISTER FILE (A01F)**

When receiving the Read register file request, the transponder shall read the requested block from Register File and send back its value in the response.

Request format:

S	Flags	Read Register File	UID	Block address	CRC 16	E
O	8 bits	8 bits	64 bits	8 bits	16 bits	O
F	00xx 001x	1010 0000 0001 1111	(Optional)			F

Response format (if no error):

S	Flags	Data	CRC 16	E
O	8 bits	16 bits	16 bits	O
F	0000 0000			F

- **WRITE REGISTER FILE (A11F)**

When receiving the Write register file request, the transponder shall write the requested block into Register File with the data contained in the request and report the success of the operation in the response.

Request format:

S	Flags	Write Register File	UID	Block address	Data	CRC 16	E
O	8 bits	8 bits	64 bits	8 bits	16 bits	16 bits	O
F	00xx 001x	1010 0001 0001 1111	(Optional)				F

- **READ INTERNAL DEVICE (A21F)**

When receiving the “Read Internal Device” request, the transponder shall read a word of the addressed internal device and send back its value in the response. The internal device is selected thanks to the address byte taking part of the command frame.

Request format:

S	Flags	Read Internal Device	UID	Block address	CRC 16	E
O	8 bits	8 bits	64 bits	8 bits	16 bits	O
F	00xx 001x	1010 0010 0001 1111	(Optional)			F

Response format (if no error):

S	Flags	Data	CRC 16	E
O	8 bits	16 bits	16 bits	O
F	0000 0000			F

- **WRITE INTERNAL DEVICE (A31F)**

When receiving the “Write Internal Device” request, the transponder shall write the addressed internal device word.

Request format:

S	Flags	Write Internal Device	UID	Block address	Data	CRC 16	E
O	8 bits	8 bits	64 bits	8 bits	16 bits	16 bits	O
F	00xx 001x	1010 0011 0001 1111	(Optional)				F

- **READ EXTERNAL MEMORY (A41F)**

When receiving the “Read External Memory” request, the transponder shall read the requested block from external memory via SPI and send back its value in the response.

Request format:

S	Flags	Read External Memory	UID	Block address	CRC 16	E
O	8 bits	8 bits	64 bits	16 bits	16 bits	O
F	00xx 001x	1010 0100 0001 1111	(Optional)			F

Response format (if no error):

S	Flags	Data	CRC 16	E
O	8 bits	16 bits	16 bits	O
F	0000 0000			F

- **WRITE EXTERNAL MEMORY (A51F)**

When receiving the “Write external memory” request, the transponder shall send a command to SPI, in order to write a byte into an external memory via SPI interface with the data contained in the request.

Request format:

S	Flags	Write External Memory	UID	Block address	Data	CRC 16	E
O	8 bits	8 bits	64 bits	16 bits	16 bits	16 bits	O
F	00xx 001x	1010 0101 0001 1111	(Optional)				F

- **SEND A SPECIFIC COMMAND TO EXTERNAL MEMORY (A61F)**

When receiving the “Send Specific Command to external memory” request, the transponder shall send a command to the external memory via SPI. Example: WREN = Write Enable, Write Disable.

Request format:

S	Flags	Send Specific CMD	UID	Command code	CRC 16	E
O	8 bits	8 bits	64 bits	8 bits	16 bits	O
F	00xx 001x	1010 0110 0001 1111	(Optional)			F

- **SEND ADDRESSED COMMAND TO EXTERNAL MEMORY (A71F)**

When receiving the “Send Addressed Command to an external memory” request, the transponder shall send a command and the address to the external memory via SPI. Example: Lock Block, Unlock Block

Request format:

S	Flags	Send Addressed CMD	UID	Address	Command code	CRC 16	E
O	8 bits	8 bits	64 bits	16 bits	8 bits	16 bits	O
F	00xx 001x	1010 0111 0001 1111	(Optional)				F

- **WRITE EXTERNAL MEMORY STATUS (A81F)**

When receiving the “Write external memory status” request, the transponder shall send specified command with data to the external memory via SPI. Example: write status register.

Request format:

S	Flags	Write External Memory Status	UID	Command Code	Data	CRC 16	E
O	8 bits	8 bits	64 bits	8 bits	8 bits	16 bits	O
F	00xx 001x	1010 1000 0001 1111	(Optional)				F

- **READ EXTERNAL MEMORY STATUS (A91F)**

When receiving the “Read external memory status” request, the transponder shall send specified command to the external memory via SPI and respond with data received from external SPI slave.

Request format:

S	Flags	Read External Memory status	UID	Command code	CRC 16	E
O	8 bits	8 bits	64 bits	16 bits	16 bits	O
F	00xx 001x	1010 1001 0001 1111	(Optional)			F

Response format (if no error):

S	Flags	Data	CRC 16	E
O	8 bits	8 bits	16 bits	O
F	0000 0000			F

- **LOCK DEVICE (B01F)**

When receiving the Lock Device request, the transponder switches to Locked state in this case any attempt to have an access to its memory or devices (whether read or write) results with an error response.

Request format:

S	Flags	Lock Device	UID	CRC 16	E
O	8 bits	8 bits	64 bits	16 bits	O
F	00xx 001x	1011 0000 0001 1111	(Optional)		F

- **UNLOCK DEVICE (B11F)**

When receiving the 'Unlock device' request, the transponder shall return device from Locked state. A security procedure based on a password is required to execute the unlocking. The password is in EEPROM #06.

Request format:

S	Flags	Unlock Device	UID	Password	CRC 16	E
O	8 bits	8 bits	64 bits	16 bits	16 bits	O
F	00xx 001x	1011 0001 0001 1111	(Optional)			F

- **UPDATE REGISTER FILE (C01F)**

Update register file command is used to quick update of contents of Register file via DMA within the image stored in EEPROM.

Request format:

S	Flags	Update Register File	UID	CRC 16	E
O	8 bits	8 bits	64 bits	16 bits	O
F	00xx 001x	1100 0000 0001 1111	(Optional)		F

- **Lock Page (D01F)**

When receiving the 'Lock Page' request, the transponder shall lock the requested EEPROM Page.

Request format:

S	Flags	Unlock Device	UID	Page number	CRC 16	E
O	8 bits	8 bits	64 bits	8 bits	16 bits	O
F	00xx 001x	1101 0000 0001 1111	(Optional)			F

- **Unlock Page (D11F)**

When receiving the 'Unlock Page' request, the transponder shall unlock the requested Page. A security procedure based on a password is required to execute the unlocking. The password is in EEPROM #06.

Request format:

S	Flags	Unlock Device	UID	Page number	Password	CRC 16	E
O	8 bits	8 bits	64 bits	8 bits	16 bits	16 bits	O
F	00xx 001x	1101 0000 0001 1111	(Optional)				F

Response error code

If the flag *Error_flag* of the response is set by the MLX90129, the error code is transmitted to provide some information about the error that occurred. Most of them are described in the standard ISO15693. The last ones are some custom codes.

Error code	Meaning	Command
01	The command is not supported, i.e. the request code is not recognized	All
02	The command is not recognized, for example: a format error occurred	All
03	The option is not supported	All
0F	Unknown error	All
10	The specified block is not available (does not exist)	Read/Write/Lock
11	The specified block is already locked and thus cannot be locked again	Lock
12	The specified block is locked and its content cannot be changed	Write
A0	The selected <i>Device</i> is locked	Write memory
A1	The selected <i>Device</i> is busy (*)	Read/Write memory
A2	The access to the selected <i>Device</i> is denied	Read/Write memory

(*) "*Device is busy*" error code occurring during a write operation means that the MLX90129 is still performing the last write operation. Then, the base-station has to wait for some time and send the command again. For read operation, it means that the selected *Internal device* (sensor ADC,...) cannot read the data and respond immediately.

The purpose of the address #11 in EEPROM is user-defined.

8.1.3 Internal Devices dedicated to RFID communication

Using the RFID (and SPI) commands called *Read-internal-device* and *Write-internal-device*, it is possible to access some registers of the *Device Address Domain*. These registers contain some status information, some settings and options, the ADC buffer of the selected sensor, the ee-Latches, etc... This so-called *Internal Device* is selected thanks to the address byte included in the command.

The following words are part of the *Device address domain*:

- The *RFID core control word* is read/write. It contains a bit used to lock the non-RFID transactions.
- The *RFID interrupt & status word* is read-only, using the RFID command *Read internal device*, and the address 0x00. It contains the status of the security units, of the pending accesses to the memories, and of the system current activity.

RFID core control word (*Devices address domain*, address #00, read/write)

Bits	Name	Description (if bit=1)
#00 – RFID core control word		
15:1	-	Unused (must be 0)
0	Core_Lock	When set to '1', it locks any transactions including the SPI interface or the DMA. This allows having an access from the RFID interface at any time. If the base station sets this bit, but the last transaction has not been accomplished yet, this latter is not interrupted. But it is still possible to access the <i>Device Address Domain</i> , via SPI.

RFID interrupt & status word (*Devices address domain, address #01, read-only*)

Bits	Name	Description (if bit=1)
#01 – RFID interrupt & status word		
15	(reserved)	
14	Irq_LowBattery	Low battery voltage detected
13	Irq_SensorFault	Sensor fault detected (bridge is broken or short-cut)
12	Irq_ExternalEvent	An external event has been detected (rising edge on pin AT). (The event detector must be activated and enabled)
11	(reserved)	
10:8	(unused)	
7	Irq_Sensor_Threshold	The output data from the sensor has crossed the defined threshold level or window
6	Irq_Timer_WakeUp	The count-down of the wake-up is over
5	Irq_DMA_ready	The DMA transaction has been completed
4	Irq_EEPROM_Full	The internal or external non-volatile memory is full
3	(unused)	
2	Transaction_Error_Flag	One of the previously executed commands has failed (delay not fulfilled, denied access, data not processed ...). This bit is automatically cleared after power-on or after read of the <i>RFID interrupt & status word</i> .
1	Last_Transaction_Status	This bit indicates whether the last request has been processed ('0') or not ('1'). In this latter case, the MLX90129 ignores any new request.
0	Core_Main_Status	The system is busy with an internal operation and the request from RFID cannot be processed.

8.2 Serial Peripheral Interface (SPI)

8.2.1 SPI : modes of operation

The SPI implemented in the MLX90129 works in Slave or Master mode.

- When the MLX90129 SPI is configured in the Slave mode, the SPI master (being a microcontroller, a Zigbee End Device, ...) controls the *serial clock* signal SCK, the *Slave Select* signal SS and transmits the data to the slave via the *Master-Out-Slave-In* signal MOSI. As a slave, the MLX90129 answers with the *Master-In-Slave-Out* signal MISO, synchronized on SCK.
- When configured in the Master mode, the MLX90129 SPI can select an external slave, typically an external serial EEPROM, and use it for data logging. The command op-codes and delays between request and response are programmed in the SPI configuration register. The master SPI controls the *Slave Select*, the *Serial Clock* signal, sends the data on MOSI and read data on MISO. It is possible to control the SPI as master thanks to custom RFID commands.

SPI is compliant with the following control options:

- Master mode and Slave mode
- CPOL=0: The clock is active-high: in the idle mode, SCK is low.
- CPHA=0: Sampling of data occurs on rising edges of SCK. Toggling of data occurs on falling edges.
- MSB first (on MISO and MOSI)
- Baud-rate: 1MHz

Detailed signal description:

- **MOSI** : this pin is used to transmit data out of the SPI module when it is configured as a Master and receive data when it is configured as a Slave.
- **MISO** : this pin is used to transmit data out of the SPI module when it is configured as a Slave and receives data when it is configured as a Master.
- **SS** : when the MLX90129 is configured as a SPI master, it controls the SS pin to select an external peripheral with which a data transfer will take place. When configured as a Slave, it is used as an input to receive the *Slave Select* signal.
- **SCK** : this pin is used to output or receive the clock.
- **IRQ** : this pin is used to interrupt the SPI master (microcontroller) process.

When the MLX90129 is not selected by the SPI master or when the received command code is not supported, the pin MISO is in tri-state. When the MLX90129 uses the SPI in the master mode (to access an external memory), it complies with the same rules for any external SPI masters.

8.2.2 Slave SPI command set

SPI command set

Command	Code	Operation
EEP_RD	0x0F	Read the addressed EEPROM word
EEP_WR	0x0E	Write the addressed EEPROM word
REG_RD	0x0D	Read the addressed register in the <i>Register File</i>
REG_WR	0x09	Write the addressed register in the <i>Register File</i>
DEV_RD	0x10	Read a word from the selected <i>internal device</i> (Control, status, ADC,...)
DEV_WR	0x18	Write a word into the selected <i>internal device</i> (Control, ee-Latches)
REG_UPDT	0x1C	Fills the <i>Register File</i> with its image stored in the EEPROM (without reboot)

8.2.3 Internal devices dedicated to SPI communication

The SPI and the RFID interfaces share the access to the memory. In order to prevent any access conflicts, and to manage the communications via SPI and RFID, two registers have been defined in the *Device Address Domain*: the *SPI Core control word* and the *SPI interrupt/status word*. They are always immediately accessible for read or write operations, even if the system is busy.

The SPI I/O signals are accompanied of an output interrupt signal IRQ. This signal may be used to wake up or to warn the SPI master (micro-controller) about some access conflicts or some general problems (low battery level, sensor fault, external event ...). It is set once one of the selected events occur. It is reset once the SPI master has read the *SPI Core interrupt / status word*, or has set the bit *Disable IRQ setting* of the *SPI Core control word*.

SPI Core control word (*Device address domain, address #00, read/write*)

Bits	Name	Description (if bit=1)
#00 – SPI Core control word		
15:7	-	Reserved (must be 0)
6:4		<i>RFID interrupts control:</i>
6	Irq_Rfid_Reg_Access_En	<i>Enable RFID Interrupt 2 (Access to Register file).</i>
5	Irq_Rfid_EEp_Access_En	<i>Enable RFID Interrupt 1 (Access to EEPROM).</i>
4	Irq_Rfid_Field_En	<i>Enable RFID Interrupt 0 (RFID field is detected).</i>
3	Irq_Last_Trans_En	<i>End of transaction</i> Enable interrupt indicating the completion of the last requested transaction. To de-assert this interrupt, the user will request another transaction, read the SPI local data buffer (in device address domain), disable this interrupt or block IRQ assertion.
2	Irq_Dis	<i>Disabled IRQ setting.</i> Disable the setting of the IRQ signal.
1	Core_Sts_Irq_En	<i>Core status interrupt enabled.</i> Enable the interrupt on IRQ telling that the system is free.
0	Core_Lock	<i>Core lock.</i> Lock any transactions between the different internal devices and the non-SPI interfaces. This allows having an access from SPI to any registers at any time. The last pending transaction is always completed.

SPI interrupt & status word (*Devices address domain, address #01, read only*)

Bits	Name	Description (if bit=1)
#01 – SPI interrupt & status word		
15	(reserved)	
14	Irq_LowBattery	Low battery voltage detected
13	Irq_SensorFault	Sensor failure detected (broken or short-cut)
12	Irq_ExternalEvent	An external event has been detected (rising edge on pin AT)
11	(reserved)	
10	Irq_Rfid_Reg_Access	The RFID interface is accessing the Register File
9	Irq_Rfid_EEp_Access	The RFID interface is accessing the EEPROM
8	Irq_Rfid_Field	The magnetic field is high enough to start a RFID communication
7	Irq_Sensor_Threshold	The output data from the sensor has crossed the defined threshold level or window
6	Irq_Timer_WakeUp	The count-down of the wake-up is over
5	Irq_Dma_Ready	The DMA transaction has been completed (in the non-loop mode)
4	Irq_Memory_Full	The internal or external non-volatile memory is full
3	Irq_Write_Failure	The non-volatile block has been written bad or weak: the data is wrong or its long-term retention is not guaranteed
2	Transaction_Error	One of the previously executed commands has failed (read delay, denied access, data not processed,...). This bit is automatically cleared after reboot or after read of the <i>SPI interrupt & status word</i> .
1	Last_Transaction_Status	This bit indicates whether the last request from SPI has been processed ('0') or not ('1'). In this latter case, the MLX90129 ignores any new request from SPI.
0	Core_Main_Status	The system is busy with an internal operation and the request from SPI cannot be processed immediately.

Interrupts

The following table summaries the information about the interrupts. For each bit of the *SPI interrupt & status word*, the condition to assert high or low the status flag, and to assert high the interrupt request on IRQ, are described. All interrupts can be disabled in asserting high the bit *Irq_Dis* of the *SPI Core control word*.

Bit	Interrupt name	Status flag assertion HIGH : conditions	Status flag assertion LOW : conditions	IRQ enable conditions
0	Core_Main_Status	The Core is busy with a transaction between different internal devices.	The Core is not busy with transactions between different internal devices	Core_Sts_Irq_En =1
1	Last_Transaction_Status	A request for a new transaction is pending	The last requested transaction with the Core has been completed. E.g. ADC is ready	Irq_Last_Trans_En =1
2	Transaction_Error	When one of previously requested commands was not executed	The user reads the <i>SPI interrupt & status word</i>	(Never)
3	Irq_Write_Failure	When one of the previously requested write-operations to a non-volatile memory has failed	The user reads the <i>SPI interrupt & status word</i>	Always
4	Irq_Memory_Full	Conditions to be fulfilled: - the DMA is busy - <i>loop enable</i> and <i>IRQ enable</i> bits are set in <i>DMA control</i> - the allocated memory is full	The user halts the DMA processing or disables the <i>IRQ enable</i> bit in <i>DMA control word</i>	Always
5	Irq_Dma_Ready	The DMA unit has completed the last requested transaction	The user reads the <i>SPI interrupt & status word</i>	Dma_IrqDataReady_En =1 in the <i>DMA configuration register</i>
6	Irq_Timer_WakeUp	The timer has completed its counting phase	The timer is requested to start a new counting phase (during the <i>automatic logging mode</i>)	WUT_Irq_En =1 in the <i>Power management configuration word</i> .
7	Irq_Sensor_Threshold	The last ADC output code crosses the defined threshold level or window	The chip is requested to read a new value of the sensor	Sensor_Irq_En =1 in the <i>Sensor control word</i>
8	Irq_Rfid_Field	A RFID field has been detected, and is strong enough to start a RFID communication	The RFID field has been removed, or is too low for a RFID communication	Irq_Rfid_Field =1 in the <i>SPI Core control word</i>
9	Irq_Rfid_EEP_Access	A RFID reader is accessing the EEPROM	The user reads the <i>SPI interrupt & status word</i>	Irq_Rfid_EEP_Access=1 in the <i>SPI Core control word</i>
10	Irq_Rfid_Reg_Access	A RFID reader is accessing the register file	The user reads the <i>SPI interrupt & status word</i>	Irq_Rfid_Reg_Access =1 in the <i>SPI Core control word</i>
12	Irq_External_Event	An event occurs and the event detector is enabled, using the appropriate EE-Latch	The event detector is disabled in the appropriate EE-Latch	Always
13	Irq_Sensor_Fault	A failure has been detected on the currently selected external sensor	A new sensor (without failure) is selected or the failure disappears	Sensor_Irq_En=1 in <i>Sensor control word</i>
14	Irq_LowBattery	The battery voltage level is too low (close to the power-on reset level)	After charging or replacement of the battery	LowBattery_Irq_En=1

8.3 Management of communication conflicts

Core Transaction Arbiter

Part of the *Digital Controller*, the “*Core transaction arbiter*” deals with several tasks:

- Grant or deny accesses of the communication interfaces to the different memories
- Manage the interrupts
- Update the status of the current operations

Memory access conflicts between SPI, RFID and DMA

The two communication channels, SPI and RFID, and the internal DMA (*Direct Memory Access*) are able to access the memories (EEPROM, registers...) or the sensor *ADC buffer*, at the same time. The potential access conflicts are managed by the *Core transaction arbiter*. A DMA transaction may be interrupted by a RFID or a SPI starting communication. The RFID (resp. SPI) transaction cannot be interrupted by a starting SPI (resp. RFID) communication, or a DMA operation. In each case, the current transaction is completed.

The priority order is the following:

1. SPI (highest priority)
2. RFID
3. DMA

Management of two subsequent transactions, from the same communication channel:

A transaction initiated via RFID or SPI should be completed before starting a new one. If a request is sent to the MLX90129 by a SPI master, or by a RFID base-station, and the current transaction is not completed, then it is dealt differently depending on its nature:

- _ the reading of the *Core interrupt / status word* is allowed at any time and its content is sent in the response.
- _ the reading of a memory (a register or an EEPROM word) is denied and an error-message response may be sent. For the SPI, it contains 0xFFFF. For the RFID, the content of the response is described in the standard protocol.
- _ if the request is not understood, it is not processed, and a flag is set in the *Core interrupt / status word*. This flag is reset once it has been read.

The Core interrupt / status word (Internal device #01)

The *Core transaction arbiter* updates its *Core interrupt / status word* at each transaction. This status word is read-only and contains some information about the processing of the incoming request. It indicates:

- _ whether the system is busy or not
- _ whether the last request has been processed
- _ whether the processing of the last request has failed
- _ the source(s) of the interrupt, if the interrupt signal on pin IRQ is asserted ‘1’.

One *Core interrupt / status word* is associated to each communication way (SPI or RFID). Its content is explained in the chapters dedicated to RFID and to SPI.

The Core Control Word (Internal device #00)

The *Core transaction arbiter* updates its *Core control word* at each transaction. This status word is read/write and contains the settings used to control the interrupt signal IRQ, and the potential interrupts from other communication channel. One *Core control word* is associated to each communication way (SPI or RFID). Its content is explained in the chapters dedicated to RFID and to SPI.

9 Device Configuration

9.1 Standalone datalogger

9.1.1 Main features

The Datalogger application is managed by the DMA (Direct Memory Access) unit. This block controls the standalone applications, without any external microcontroller. It handles the start-up operations, and sends the data from a programmed source towards a programmed destination, using flexible protocol and interrupt conditions. Typically, it may get the data from the sensor interface and store it in an EEPROM. It works on defined time periods controlled by a wake-up timer.

Its main features are the following:

- The configuration registers are filled from the EEPROM at the start-up (when enabled)
- The duty-cycle (ratio between active and sleep mode) is controlled by a wake-up timer (WUT) that wakes the system up after a programmed delay
- Programmed behaviour (source, destination, interrupt options, master-SPI options, ...)
- Programmable command-set to address any kind of external SPI memory
- Programmable timings used in the SPI protocol of the external memory (between the request and the response)
- Calculation of the address of the destination.

9.1.2 DMA operations

Loading of the register file from the EEPROM data.

_ At the power-up of the battery, the DMA automatically loads the *Register File* with its image from the EEPROM. A bit stored in the EE-Latch bank, called *Disable Automatic Loading*, can be set to disable this automatic loading.

_ At any time, the RFID or the SPI interface can send an *Update* command to update the content of the *Register File* with the values stored in the EEPROM.

_ The configuration may be chosen in such a way that DMA operations start automatically at power-up.

Data logging in the internal or external EEPROM

_ After power-up, the DMA loads the *Register File* with the data stored in the EEPROM (it also loads its own configuration).

_ The wake-up timer (WUT) starts counting to a programmed value. During this counting, the MLX90129 works in a *sleep mode*, consuming a very low power. To save power, the duty cycle should be as low as possible.

_ At the end of the counting, the WUT wakes the DMA up.

_ The DMA loads the configuration registers of the selected sensor, and starts a sensor acquisition.

_ The result data is then stored in the EEPROM, at an address calculated from a programmed value.

_ Depending on the options, the DMA may configure and start an acquisition of another sensor, or may let the system enter the *sleep mode*. If another sensor is selected, then the DMA loads the new sensor configuration before starting the acquisition.

At any moment, this process may be interrupted by an external microcontroller, to read the data collection. For that, it asserts low the bit *Processing Control* of the *DMA configuration register*. Then, the process may be hold or reset. In order to store only the latest data from ADC, the bit *Loop enable* must be set. In this case, the old data is rewritten by the DMA unit with the new one when the memory border has been reached. When the memory is completely filled, a *Full Memory* interrupt appears on the pad IRQ. It is also possible to send

an interrupt request (IRQ) to the external microcontroller after each Wake-up timer period. Then, the microcontroller may decide to read the sensor output data and process it.

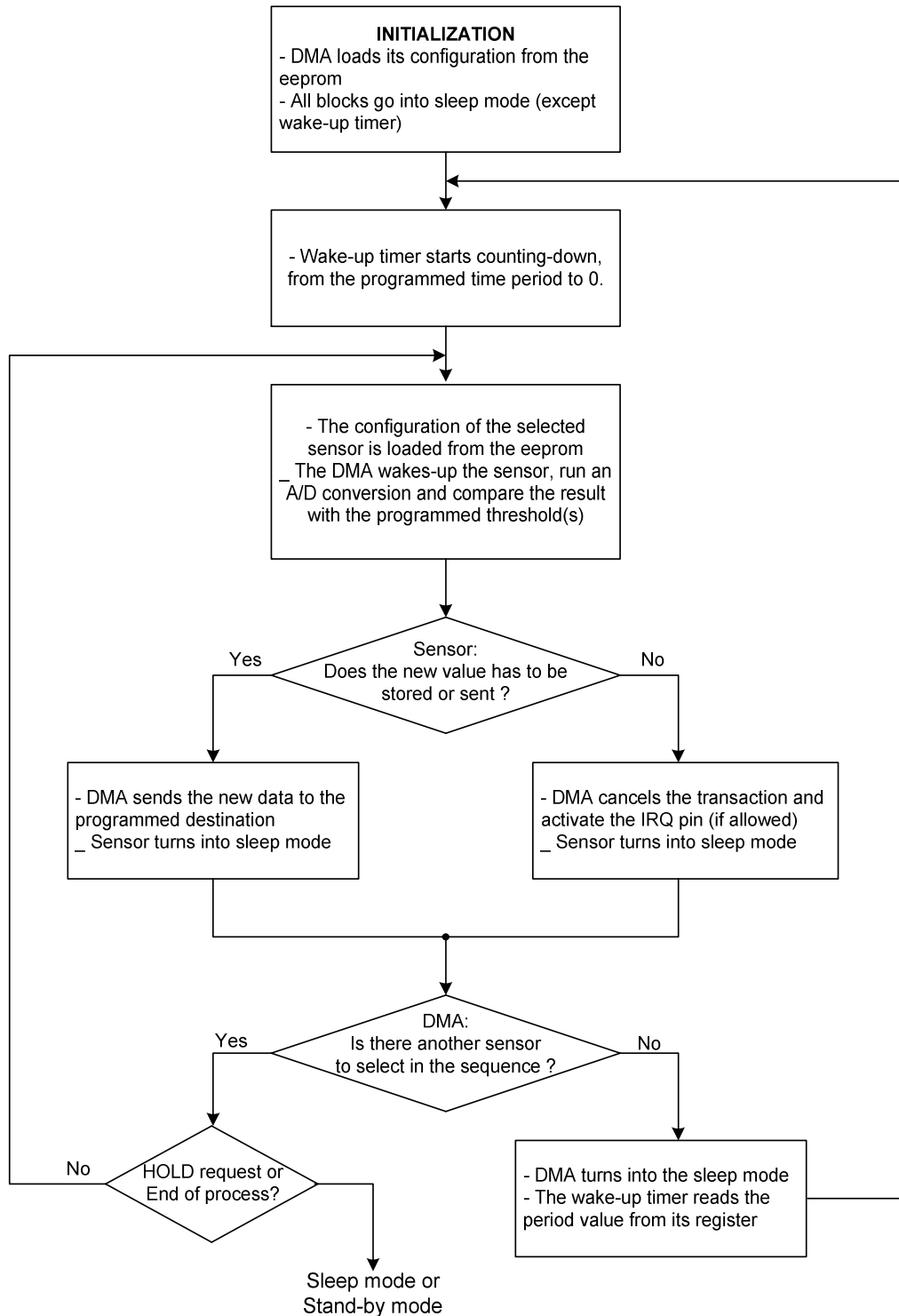

Interrupt of DMA process

The microcontroller or the RFID base-station can read the *DMA status register* and access the *DMA configuration register* to start and control the DMA processing. At any time, they can hold the DMA process and check the current status of the copied data (telling how many words have been copied). Then, they can change the DMA configuration to a new one or continue the processing. While the DMA is processing data or is on hold, any change of the parameters in the DMA configuration words does not cause the expected changes in the behaviour.

End of DMA process

At the end of the sequence, the MLX90129 may enter its sleep mode or its stand-by mode. During the *Sleep mode*, the system may be interrupted by a RFID field, or by the SS line asserted low during 1.5ms.

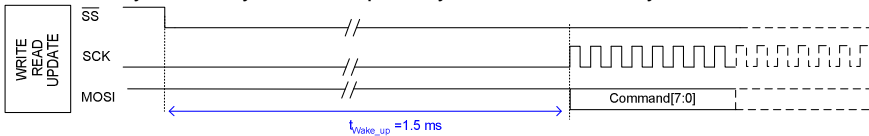

9.1.3 Setup of the Automatic Logging Mode

Setup

In order to enable the *automatic logging mode*, the following sequence must be run:

- _ Setup the *DMA configuration word*
- _ Setup the *DMA source start address, DMA destination start address and the DMA length*.
- _ If an external EEPROM is used, setup the *SPI-master configuration and command word*
- _ setup the sensor interface configurations in the EEPROM.
- _ Setup the Sensor control word and the Sensor thresholds words (if required)
- _ Setup the Wake-up Timer configuration word
- _ Setup the logging period in the wake-up timer
- _ To enable the DMA operation, the bit *Processing Control* of the *DMA configuration register* must be reset.
- _ Set the bit *Automatic Logging enable* in the wake-up timer configuration to '1'.

All these actions can be performed automatically after the system boot: the required configuration can be set in the EEPROM. Then, after power-on, the system reads this configuration and performs the programmed actions. It is not mandatory to store all the data from a sensor at each iteration, but only the data fitting the conditions defined in the bits *Data logging control* of the register word called *Sensor[x] Control word*.

Logging several sensors and time-stamp

When more than one sensor is selected as a source of automatic logging, the DMA stores subsequently all the sensor output data in the selected memory. The stored data has a prefix to identify them:

Bit	15:14	13:0
Definition	Prefix	ADC output code

The prefix code is defined in the following table:

Prefix code	Related sensor or parameter
00	Sensor 0
01	Sensor 1
10	Sensor 2
11	Iteration index (Time stamp)

9.1.4 Direct Memory Access configuration

DMA configuration words (EEPROM & Register, address #09 to #0C, read/write)

Bits	Name	Description (when bit = '1')
#09 – DMA Control word		
15:12		<i>Sensing sequence</i>
15	DMA_Time_Incl	include the iteration index (time stamp) in the memory
14	DMA_Sensor2_Incl	include the measurement and the storing of sensor 2
13	DMA_Sensor1_Incl	include the measurement and the storing of sensor 1
12	DMA_Sensor0_Incl	include the measurement and the storing of sensor 0
10:11		Reserved (must be 00)
9	DMA_LastWordMask	Disable the copying of the LSB (byte) of the last word in the datalogging sequence in the external EEPROM
8	DMA_FirstWordMask	Disable the copying of the MSB (byte) of the first word in the datalogging sequence in the external EEPROM
7:6	DMA_DestinationCode	<i>Destination of the data transfer</i> 00 : register file 01 : internal EEPROM* 10 : SPI as master (external EEPROM) 11 : (reserved)
5:4	DMA_SourceCode	<i>Source of the data transfer</i> 00 : (reserved) 01 : internal EEPROM 10 : SPI as master (external EEPROM) 11 : Sensor interface
3	DMA_LoopEn	Enable an eternal loop of data logging. In this case, after having copied <i>Length</i> words, the DMA unit does not stop its operation but sets its address to the initial one and goes on copying data.
2	DMA_IrqDataReady_En	<i>IRQ Data-transfer enabled.</i> The IRQ signal is set when the data transfer has been completed.
1	DMA_Hold	<i>Hold.</i> The DMA holds its operation till this bit goes low. The current ongoing DMA transaction is always completed.
0	DMA_Processing_Control	<i>Manual processing control.</i> '0': Manual stop of DMA (used for automatic data-logging) '1': Manual start of DMA (not for automatic data-logging)
#0A – DMA: Source start address		
15:0	DMA_Source_Address	Address of the first word to be copied from the source device.
#0B – DMA: Destination start address		
15:0	DMA_Destination_Address	Address of the first word to be filled into the destination device.*
#0C – DMA: Length		
15:0	DMA_Data_Length	Length of the block to be copied (in words).*

* /\ in case of datalogger application with sensor data logged into the MLX90129 internal EEPROM, care should be taken to not overwrite the configuration value in EEPROM [from #00 to #28]. For this reason:

- DMA_Destination_Address should be at least 0x29
- DMA_Data_Length should have the maximum value of 0xD7 (in case of DMA_Destination_Address is 0x29) in order to not exceed the address 0xFF

DMA status register (Device Address Domain, #05, read only)

Bits	Name	Description
#05 - DMA status register		
15:0	DMA_Current_Destination_Address	Address of the block of memory in the destination address domain (which is still not filled with data from the source device).

9.1.5 Wake-up timer / Power management configuration

The Wake-up timer is used for two purposes:

- to wake-up the microcontroller after a defined delay via the IRQ pin
- to enable and sequence the periodical logging of data from the sensor
- to enter the stand-by mode after a programmed delay

The following table contains the control options of this timer:

Wake-up timer (WUT) / Power management configuration words
(EEPROM & register, addresses #0F and #10, read / write)

Bits	Name	Description (when =1)
#10 – Timer Control word		
15:6	-	Reserved (must be 0)
5:4	WUT_Precision	Precision. Defines the time unit for the specified timer wake-up period (called <i>Count-down period</i>). 00: time in ms 01: time in s 10: time in min 11: time in hours
3	WUT_AutoStandby_En	Automatic stand-by enabled. Allow the MLX90129 to automatically enter the stand-by mode after the end of the wake-up timer count-down, or after completion of the automatic logging (if it is enabled).
2	WUT_AutoLog_En	Automatic logging mode enabled. If this bit is set to '1', the wake-up timer loads its value from the Register file and starts a count-down. As soon as it reaches 00h, it allows to run one or several sensor acquisitions and to store the data in the programmed destination. Then, it loads its count-down period again and starts counting. This process may be halted by resetting this bit to '0'.
1	LowBattery_Irq_En	Low-battery interrupt enabled. Enable interrupts from Low-battery detector.
0	WUT_Irq_En	Timer IRQ enabled. The timer starts its operation and generates IRQ signal after passing specified period.
#0F – Timer period		
15:0	WUT_CountDownPeriod	Combined with the WUT_Precision , this parameter defines the period between two measurements. If N is the conversion into decimal value of the WUT_CountDownPeriod hexadecimal value, the nominal logging period will be: WUT_Precision = 00 -> Period = N * 0.9765625 ms WUT_Precision = 01 -> Period = N * 1 s WUT_Precision = 10 -> Period = N * 1 min WUT_Precision = 11 -> Period = N * 1 hour

9.1.6 Master SPI configuration

A bit of the *Device security map* is used to set the SPI as master. Then, the MLX90129 controls the clock SCK, the slave-select SS (output), and the communication I/O MOSI (output) and MOSI (input).

The SPI configuration words are used to setup the parameters of the SPI-master interface, in order to access an external memory (a serial SPI EEPROM). In master mode, the SPI may be used by the internal DMA unit (Direct Memory Access) to store the output data of the sensor. The stored data may be read back by a RFID base-station.

Master SPI configuration words (EEPROM & Register, #0D and #0E, read/write)

Bits	Name	Description
#0D – External memory control word		
15:8	SPI_WriteEn_Code	Write enabled command code. Command op-code of the “write enable” operation, used toward an external EEPROM.
7	SPI_BurstMode_En	Burst mode enable: enable the write burst mode used in some SPI serial EEPROM. (*)
6:4	SPI_WriteDelay	Write delay. Delay which is inserted between a write command and another subsequent command. Precision is 4 ms. Minimal write delay calculation equation, when value of this field is non-zero: $t_{WC} = 4 \times \text{WriteDelay} - 1$ (ms).
3:2	SPI_WriteEn_Ctrl	Write enable operation control. Defines when the <i>Write Enable</i> command must be applied: 00 - never 01 - reserved 10 - before every write operation 11 - reserved
1:0	SPI_AddressMode	Addressing mode. Defines the address length to be passed via SPI for a proper EEPROM addressing. 00 - 8-bit address is used 01 - 16-bit address is used 10 - 24-bit address is used (8 MSB are filled with 00 or 01) 11 - reserved
#0E – External memory command codes word		
15:8	SPI_WriteCode	Write command code. Command op-code used by MLX90129 to write in an external memory block
7:0	SPI_ReadCode	Read command code. Command op-code used by MLX90129 to read from an external memory block

(*) Note:

The setting of the bit *Burst mode enable* switches all subsequent transactions with an external memory into burst mode. It means, that only the first memory access transaction requires sending a command and an address. After completion of this first transaction, the master SPI of the MLX90129 does not set the SS signal to ‘1’. When a new block has to be read / written, the SPI master skips the command and address phases and immediately sends or receives data to or from the external memory (it allows a page access).

9.2 Sensor Signal Conditioner

9.2.1 Block description

The sensor signal conditioner amplifies and filters the sensor output signal, before converting it to a digital format.

These are its main features:

- Two programmable gain amplifiers (PGA1 and PGA2)
- Programmable offset level (DAC)
- 16-bit A/D converter
- Internal temperature sensor
- Two selectable external differential or single-ended sensors
- Voltage regulator, to supply internal and external devices
- Sensor fault detector
- Programmable serial resistor connected to the external sensors

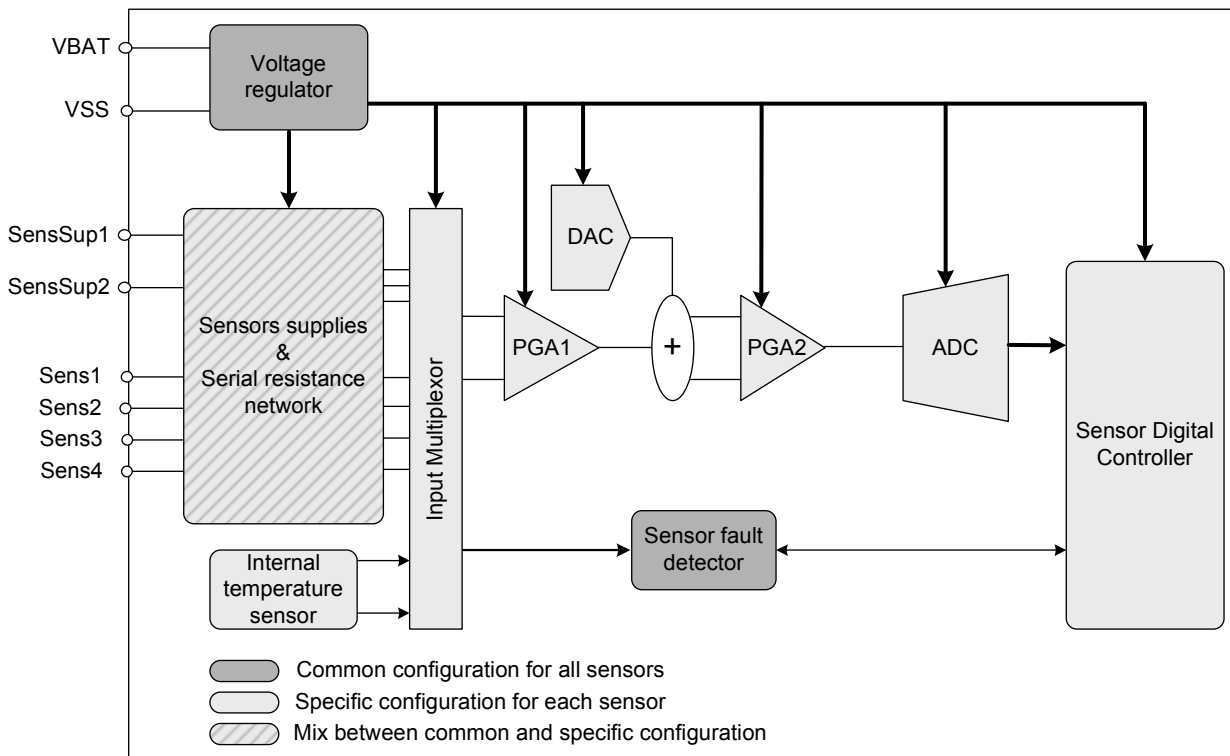

Voltage regulator

This block provides the signal conditioner chain and the external sensors with a programmable, stable voltage for a wide range of sourced currents.

Internal temperature sensor

This block gives a temperature-dependent voltage. As all other sensors, it must be calibrated to give accurate data.

Sensor supplies & Resistor network

Many combinations of resistors connections with the external sensors are possible. All the switches figured on the following schematic are independently programmable via register #1A. The supply VDDA is the stabilized output of the voltage regulator. The configuration register #19 is used to connect an external sensor or internal resistance to the inputs of the analogical chain (called MUX OUT1 and MUX OUT2).

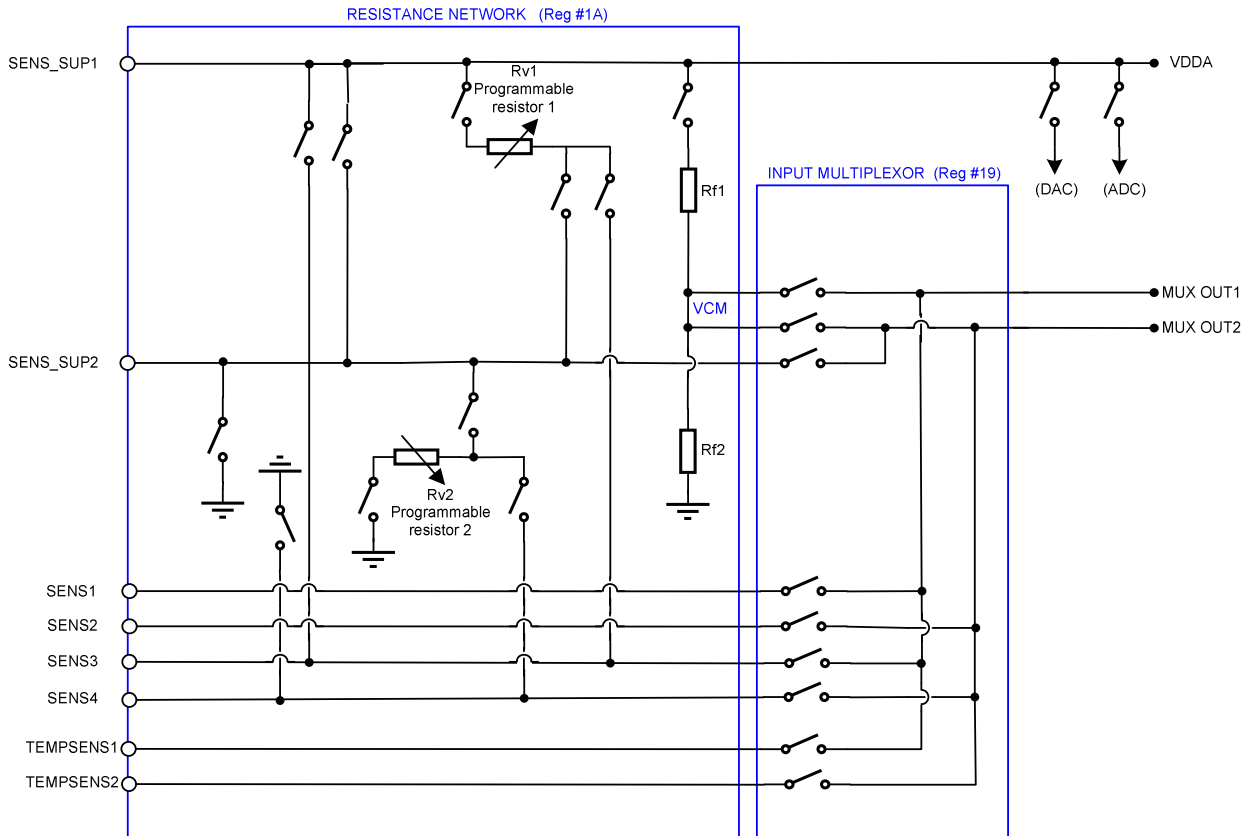

Input multiplexer

This block allows selecting the sensor signal which will be connected to the first amplifier of the signal conditioner. It is possible to select the external sensor(s) connected to SENS1, SENS2, SENS3 and SENS4, or the internal temperature sensor.

Programmable amplifier 1 (PGA1)

This block is the first programmable amplifier of the analog chain. It has a wide range of gain and is fully differential. It is compliant with a wide range of input common-mode voltage.

$$\Delta PGA1_Out = Gain1 * \Delta PGA1_In$$

Where:

$\Delta PGA1_Out$ is the differential output voltage of the Programmable Amplifier 1

Gain1 is the gain of the Programmable Amplifier 1

D/A converter (DAC)

This block is used to compensate the offset of the sensor and of PGA1, amplified by PGA1. It is also used to choose the value of the physical sensed value, for which the ADC will give its middle code.

Programmable amplifier 2 (PGA2)

This block amplifies (with a programmable gain) the output voltages of PGA1 and of the DAC, following the equation:

$$\Delta\text{PGA2_Out} = \text{Gain2} * [\Delta\text{PGA1_Out} - \Delta\text{DAC_Out}]$$

Where:

$\Delta\text{PGA1_Out}$ is the differential output voltage of the Programmable Amplifier 1

$\Delta\text{PGA2_Out}$ is the differential output voltage of the Programmable Amplifier 2

$\Delta\text{DAC_Out}$ is the differential output voltage of D/A converter

Gain2 is the gain of the Programmable Amplifier 2

A/D converter (ADC)

This block converts into a digital format the output voltage of PGA2.

Sensor fault detector

A detector may be used to detect a failure in the external sensor. The sensor supply and outputs may be broken or short-cut.

All the potential failures can be tested by selecting the sensor terminal and comparing it with the appropriate voltage reference. This can be done by programming the configuration register #14 of the *Analog Configuration Space*. The comparison result is stored in the *RFID/SPI Core interrupt/status word*.

If it is enabled, the detection of a failure causes an interrupt on IRQ. The nature of the failure may be deduced from the configuration bits that were used when it has been detected.

Sensor Digital Controller

The main features of the sensor digital controller block are:

- Initialization of the sensor interface, and running of the A/D conversions
- Buffer the ADC output code (in one of the 3 ADC buffers) when conversion has been completed
- Digital data processing: main calculation, comparison with threshold values
- Take the decision to store the data, and/or configure the conditions to generate an interrupt on IRQ.

Before any A/D conversion, the configuration of the sensors must be stored in the register file at addresses from #12 to #1A. Each sensor has its configuration stored in EEPROM. Depending on the selected sensor, the appropriate data will be copied from EEPROM to the register file.

The configuration of the selected sensor is automatically loaded from EEPROM when:

- Using commands Read Internal Device #07, Read Internal Device #08, for the first time.
- Using a command Read Internal Device #XX different from the previous one.

The configuration of the selected sensor is **not** automatically loaded from EEPROM when:

- Using command Read Internal Device #06, for the first time.
- Using the same command Read Internal Device as the previous one.

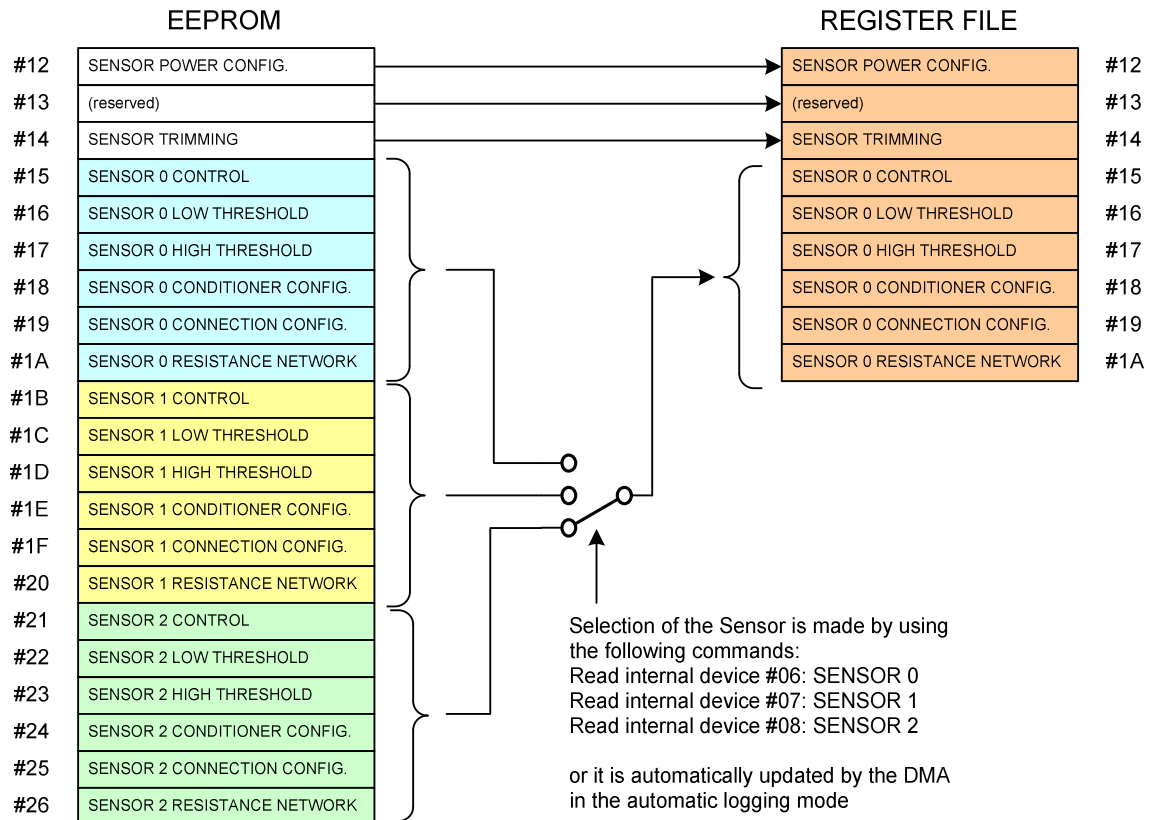

9.2.2 Sensors common configuration

The following registers manage the sensor power configuration, the sensor fault detector and the trimming of the internal resistor. This configuration is applicable for all the sensors.

Sensor's power configuration words (EEPROM & Register, #12, read / write)

The sensor's power configuration register allows disabling unused blocks in order to save power.

Bits	Name	Content	0= not powered (disabled)	1= powered (enabled)
#12 – Sensors power configuration word				
0	Sensor_Pga1_En	PGA1 enable bit		
1	Sensor_Pga2_En	PGA2 enable bit		
2	Sensor_Dac_En	DAC enable bit		
3	Sensor_Adc_En	ADC enable bit		
4	Sensor_Reg_En	Voltage Regulator enable bit		
5	Sensor_DacBuf_En	DAC buffer enable bit		
6	Sensor_Bias_En	Bias block enable bit		
7	Sensor_Temp_En	Temperature sensor enable bit		
8	Sensor_Sfd_En	Sensor fault detector enable bit		
9	Sensor_Ats_Pwr_En	Event detector power-on bit		
10	(not used, must be 0)			
11	Sensor_Ats_En	Event detector enable bit		
12	Sensor_BatMon_En	Battery monitor enable bit		
13	ExtSupplyMode	0: the regulator always supplies the external device 1: the regulator supplies it only in its watchful state (to save power)		
15:14	(not used, must be 0)			

Sensor's common configuration words (EEPROM & Register, #13 and #14, read / write)

This EEPROM-word is used to trim the value of the programmable serial resistance connected to the sensor. Serial resistance Rv1 and Rv2 have the same value. It is also used to program the connection between the external sensor and the sensor fault detector.

Bits	Name	Content
#13 - Reserved		
15:0	Reserved	Must be filled with 0x0000
#14 – Programmable resistance trimming and fault-detector configuration word (Common for all sensors)		
5:0	Sensor_Res_Trim	Trimming of the programmable resistances Rv1 and Rv2: Bits[5-0]=0 : the serial resistance is 0.5kΩ Bit[0]=1 → add 0.5kΩ to the serial resistance Bit[1]=1 → add 2kΩ to the serial resistance Bit[2]=1 → add 4kΩ to the serial resistance Bit[3]=1 → add 8kΩ to the serial resistance Bit[4]=1 → add 16kΩ to the serial resistance Bit[5]=1 → add 32kΩ to the serial resistance
9:6	Melexis calibration: do not change this value	
15:10	Sensor_Fault_Cfg	Sensor fault detector: selection bits Comparator input “+” is connected to: Bit[15:13]=000: VSS Bit[15:13]=001: 0.95*VDD Bit[15:13]=010: 0.75*VDD Bit[15:13]=011: 0.5*VDD Bit[15:13]=100: 0.25*VDD Bit[15:13]=101: 0.05*VDD Bit[15:13]=110: SENS2 Bit[15:13]=111: DAC output Comparator input “-” is connected to: Bit[12:10]=000: VSS Bit[12:10]=001: SENS1 Bit[12:10]=010: SENS2 Bit[12:10]=011: SENS3 Bit[12:10]=100: SENS4 Bit[12:10]=101: SENSSUP1 Bit[12:10]=110: SENSSUP2 Bit[12:10]=111: VSS

9.2.3 Sensor specific configuration

The following registers configure the sensor acquisition chain. This configuration is sensor specific.

Sensor control word (EEPROM & Register, address #15. EEPROM only, addresses #1B, #21)

Bits	Name	Description (when =1)
#15 - Sensor control word		
15:14	ADC_Mode	ADC mode 00: higher speed, but lower accuracy 01, 10: intermediate modes 11: lower speed, but higher accuracy
13:12	Sensor0_InitTime	Sensor initialization time 00: 150µs (= default initialization time for the internal sensor) 01: 2ms 10: 16ms 11: 128ms
11	Sensor0_Irq_En	Fault interrupt enabled. Enable the interrupt from <i>sensor fault detector</i>
10	Sensor0_Irq_Above	Interrupt conditions control - generate an interrupt when the last sample is above the programmed high threshold
9	Sensor0_Irq_Betwn	- generate an interrupt when the last sample is between the programmed high and low thresholds
8	Sensor0_Irq_Below	- generate an interrupt when the last calculated sample is below the programmed low threshold
7	ADC_LowPower	Low power mode. Enable the low power mode of the ADC.
6	ADC_DataLogAbove	Data logging control - store the calculated samples above the high threshold - store the calculated samples between the high and low thresholds - store the calculated samples below the low threshold
5	ADC_DataLogBetwn	
4	ADC_DataLogBelow	
3:2		Reserved (00)
1:0	ADC_Proc_Ctrl	Samples processing control Defines the rules for the calculation of the value which will be stored in the <i>ADC buffer</i> 00 - single sample 01 - average of 2 samples 10 - average of 8 samples 11 - average of 32 samples
#1B - Sensor 1 control word		
15:0	Same as above	Same as above
#21 - Sensor 2 control word		
15:0	Same as above	Same as above

Sensor thresholds (EEPROM & Register, addresses #16 and #17. EEPROM only #1C, #1D and #22, #23)

Bits	Name	Description
#16 - Sensor 0 low threshold		
15:0	Sensor0_ThresLow	Sensor 0 low threshold word
#17 - Sensor 0 high threshold		
15:0	Sensor0_ThresHigh	Sensor 0 high threshold word

#1C – Sensor 1 low threshold		
15:0	Sensor1_ThresLow	Sensor 1 low threshold word
#1D – Sensor 1 high threshold		
15:0	Sensor1_ThresHigh	Sensor 1 high threshold word
#22 – Sensor 2 low threshold		
15:0	Sensor2_ThresLow	Sensor 2 low threshold word
#23 – Sensor 2 high threshold		
15:0	Sensor2_ThresHigh	Sensor 2 high threshold word

Signal Conditioner words (EEPROM & Register, addresses **#18**. EEPROM only **#1E** and **#24**)

The MLX90129 can handle 2 different external sensors and 1 internal sensor. Each of these sensor output signals can be conditioned in a different way, using different values of gains and DC levels (offset). The chopper option can be used to get rid of the internal offset of the programmable amplifiers. It is effective only when the averaging option of ADC is used. The chopper enable makes the ADC conversion longer.

Bits	Name	Content
#18 - Sensor 0: Signal Conditioner configuration word		
7:0	Sensor0_DacCode	DAC code, for Sensor0 (offset or level shifter): 00000000: 0 01111111: Vref/2 10000000: 0 11111111: -Vref/2
11:8	Sensor0_Pga1Gain	Gain of PGA1: 0000: Gain=8 0001: Gain=10 0010: Gain=12.6 0011: Gain=15.5 0100: Gain=19.6 0101: Gain=24.5 0110: Gain=30.8 0111: Gain=38.1 1000: Gain=47.6 1001: Gain=59.4 1010 to 1111: Gain=75
14:12	Sensor0_Pga2Gain	Gain of PGA2: 000: Gain=1 001: Gain=2 010: Gain=3 011: Gain=4 100: Gain=5 101: Gain=6 110: Gain=7 111: Gain=8
15	Sensor0_Chopper_En	Chopper enable 1: enabled
#1E - Sensor 1: Signal Conditioner configuration word		
15:0	Same as above	Same as above
#24 - Sensor 2: Signal Conditioner configuration word		
15:0	Same as above	Same as above

Sensor connection words (EEPROM & Register, addresses #19. EEPROM only #1F and #25)

The first amplifier (PGA1) of the conditioning chain may be connected to the internal / external sensors in some different ways. Each sensor has its own connections, programmed in the following EEPROM words:

Bits	Name	Content
#19 - Sensor 0: Connections configuration word		
9:0	Sensor0_MuxCfg	Input multiplexer selection bits (connecting the multiplexer inputs to the first amplifier PGA1) Bit[0] = 0 → Mux out1= SENS1 (default) Bit[1] = 1 → Mux out1= SENS3 Bit[2] (not used = 0) Bit[3] = 1 → Mux out1= VCM (=VDD/2) Bit[4] = 1 → Mux out1=Temp. sensor output1 Bit[5] = 0 → Mux out2= SENS2 (default) Bit[6] = 1 → Mux out2= SENS4 Bit[7] = 1 → Mux out2= SENSSUP2 Bit[8] = 1 → Mux out2= VCM Bit[9] = 1 → Mux out2=Temp. sensor output2
15:10	Reserved, Must be 00000	
#1F - Sensor 1: Connections configuration word		
9:0	Sensor1_MuxCfg	Same as above
#25 - Sensor 2: Connections configuration word		
9:0	Sensor2_MuxCfg	Same as above

Sensor serial resistance conditioner words (EEPROM & Register, addresses #1A. EEPROM only #20 and #26)

Each of the 3 sensors called Sensor0, Sensor1, and Sensor2 can be connected to some serial resistances in order to reduce their current consumption, or to set their common-mode level.

Bits	Name	Content
#1A - Sensor 0 serial resistance configuration word		
15	Sensor0_Temp_En	Bit[15]=1 -> enables the temperature sensor
14:0	Sensor0_Res_Cfg	Resistance network configuration: Bit[0] (not used=0) Bit[1]=1 → SENSSUP2 = VDDA Bit[2]=1 → SENS3 = VDDA Bit[3] (not used=0) Bit[4]=1 → SENSSUP2 = VSS Bit[5]=1 → SENS4 = VSS Bit[6]=1 → VCM = VDD/2 (enabled) Bit[7]=1 → connects programmable resistance 1 to VDD Bit[8]=1 → connects programmable resistance 2 to VSS Bit[9] (not used=0) Bit[10]=1 → connects programmable resistance 1 to SENSSUP2 Bit[11]=1 → connects programmable resistance 1 to SENS3 Bit[12] (not used=0) Bit[13]=1 → connects programmable resistance 2 to SENSSUP2 Bit[14]=1 → connects programmable resistance 2 to SENS4
#20 - Sensor 1 serial resistance configuration word		
15:0	Same as above	Same as above
#26 - Sensor 2 serial resistance configuration word		
15:0	Same as above	Same as above

9.3 Power management

The power management unit controls the following features of the MLX90129:

- Start-up modes (with or without battery)
- Power modes (stand-by, sleep, watchful or run mode)
- Energy scavenging for battery-less applications
- Oscillators management (digital clock, wake-up timer)

9.3.1 Power modes

Power-off mode

No battery, no field. The MLX90129 can quit this mode when a battery is connected or when a RF field is applied.

Watchful mode

This mode is the initial state, after power-on. In this state, the digital part is activated; the MLX90129 can receive commands from the RFID or SPI.

Run mode

Depending on the command from SPI or RFID, or on request from DMA, the MLX90129 enters the Run mode, where all the blocks implied in the transaction are powered. This state is not low-power, but time-limited.

Stand-by mode

In the stand-by mode, the supply voltage is applied, but the MLX90129 consumes a minimum current. Typically, this mode is used after the module has been assembled and tested. Then, it can be stored for a long time without wasting the battery energy.

The Digital Controller can not exit this mode by itself. It can only exit it by an external interrupt: emission of a RFID field or asserting low the Slave Select input of the SPI (during a specified time)

The MLX90129 may re-enter this mode upon request from SPI or RFID (in writing the Wake-up Timer configuration word). It is possible to enter this mode after a programmed count-down from the Wake-up timer, or after a logging sequence.

Sleep mode

In the *Sleep mode*, only the wake-up timer works and sends an IRQ pulse (Interrupt Request) to the microcontroller after a programmable time period. The MLX90129 may leave this mode in the following cases:

- _ emission of a RFID field
- _ asserting low the Slave Select input of the SPI (during a specified time)
- _ DMA request to run an acquisition after a defined time period.

In the sleep and the stand-by modes, it is possible to power-down the external device supplied by VREG.

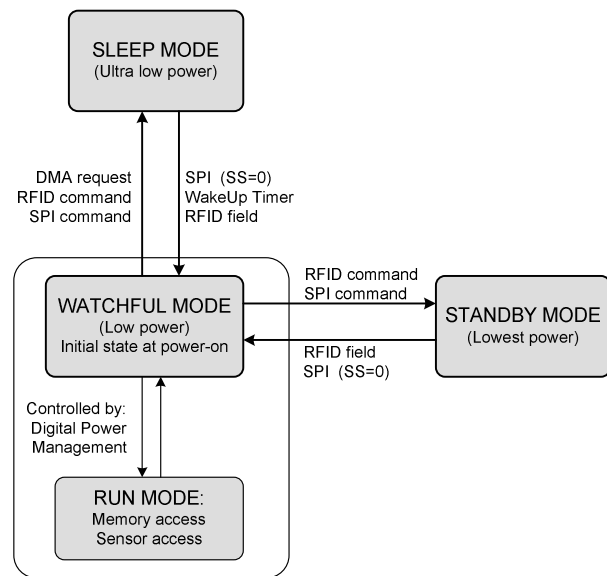

9.3.2 Oscillators management

The MLX90129 contains 3 oscillators:

- A low-power low-frequency RC-oscillator (that may be used as a wake-up timer)
- A low-power low-frequency quartz oscillator (that may also be used as an accurate wake-up timer)
- A 5MHz RC-oscillator for the digital clock

The two RC-oscillators have their frequency adjustable, by programming the EE-Latches bank. The use of the quartz oscillator is optional. If it is chosen instead of the RC-oscillator, then a 32.768kHz crystal should be connected between the pads XIN and XOUT.

9.3.3 Energy scavenging

The MLX90129 embeds power supply management capabilities which allow a strong flexibility to design data logger devices with strong power consumption constraints. It is possible to store the energy from the incoming magnetic field into an external capacitor, on pad VFIELD or to run from a coin cell battery.

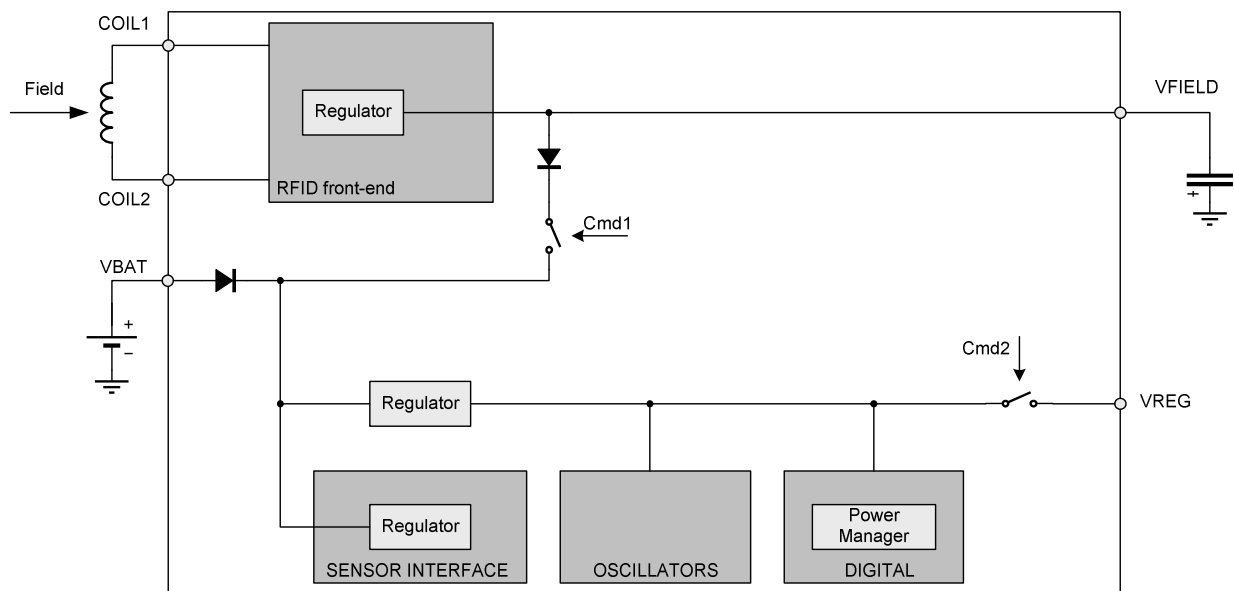

The power management mode is defined by the switches Cmd1 and Cmd2 and is configurable through the EEPROM and EE-Latch.

- For the battery-less applications, VFIELD pad can be used to supply the MLX90129 if the switch between VFIELD and VBAT (Cmd1) is closed.
- For battery applications, the switch between VFIELD and VBAT should (Cmd1) be open
- For both kind of application, it is possible to supply the external device via VREG, either at any time, or only in watchful state (Cmd2 closed)

The commands of these switches are defined as:

Cmd1: *Disconnect_Vfield_Vbat* = EE-latch #03, bit 15

Cmd2: *ExtSupply_En* = EEPROM #12, bit 13

9.4 Security

9.4.1 Communication security

The *Device Security Register* is stored in the EEPROM. It contains the access rights to the different memories by the RFID interface. It allows a partial or complete disabling of the RFID interface. In addition, it controls the functionality of the SPI by making it master or slave.

Device security map configuration register (EEPROM & Register, address #05, Read/Write)

Bits	Name	Description (when bit = 1)
#05 - Device security map		
15:14	-	Reserved (must be 00)
13	Rfid_Page0Read	Allow read access to Register file page 0 for RFID.
12	Rfid_Page0Write	Allow write access to Register file page 0 for RFID.*
11	Rfid_EEpViaDma	Allows RFID access to internal EEPROM via DMA.
10	Rfid_Adc_Access	Allow access to ADC buffer for RFID
9	Rfid_Int_Read	Allow a read access to the external memory by RFID
8	Rfid_Int_Write	Allow a read & write access to the external memory by RFID *
7	Rfid_EE1_Read	Allow a read access to EE-Latches by RFID
6	Rfid_EE1_Write	Allow a read & write access to EE-Latches by RFID *
5	Rfid_Reg_Read	Allow a read access to the Register file page 1by RFID
4	Rfid_Reg_Write	Allow a read & write access to the Register file page 1 by RFID *
3	Rfid_Lock_Dis	Disable the RFID Core-lock access function
2		Reserved (must be 0)
1	Rfid_Dis	Disable the RFID communication media
0	Spi_Master	SPI slave disable. Disable SPI-slave and enable activity of SPI-master.

*note: if the write-access is allowed, the read-access is also allowed, independently of the value of the read access bit

9.4.2 EEPROM Access security

The access to the EEPROM words is protected depending on their content. Three security levels have been defined and can be chosen for any EEPROM page. If any external device tries to access via SPI a memory location without permission, it obtains value 0xFFFF as result. Via RFID, the error response is defined by the standard ISO15693.

- Definition of the different security levels

Security level	Code	Write access	Read access	Typical application
L0	00	SPI, DMA	SPI, DMA	UID and security configuration
L1	01	SPI, DMA	SPI, RFID, DMA	
L2	10	SPI, RFID, DMA	SPI, RFID, DMA	Register file initial configuration, data logging Customer ID, Unlocked User Data
L3	11	Reserved	Reserved	

- EEPROM security access levels

The user data are separated in 8 pages, whose access levels (L0 to L3) are defined thanks to 2 bits, stored in the 'Security Map Register' of the EEPROM. A security procedure based on a password is required to execute the unlocking. The password is stored in EEPROM #06.

EEPROM security map

Page	Address (hex)	Access level	Words	Description
0	0x00 - 0x08	L0	9	Page 0: Melexis ID and device security
1	0x09 - 0x26	programmable	30	Page 1: Register file initial image
2	0x27 - 0x3F	programmable	25	Page 2: User defined data, Customer ID
3	0x40 - 0x5F	programmable	32	Page 3: User defined data
4	0x60 - 0x7F	programmable	32	Page 4: User defined data
5	0x80 - 0x9F	programmable	32	Page 5: User defined data
6	0xA0 - 0xBF	programmable	32	Page 6: User defined data
7	0xC0 - 0xFF	programmable	64	Page 7: User defined data

EEPROM security map register (EEPROM, address #04)

Bits (security level)	Description
[15:14]	Access level for EEPROM Page 7
[13:12]	Access level for EEPROM Page 6
[11:10]	Access level for EEPROM Page 5
[9 : 8]	Access level for EEPROM Page 4
[7 : 6]	Access level for EEPROM Page 3
[5 : 4]	Access level for EEPROM Page 2
[3 : 2]	Access level for EEPROM Page 1
[1 : 0]	Reserved (must be 0x00)

10 Application Information

1. RFID temperature sensor tag

The MLX90129 may be used as a 13.56 MHz sensor transponder. The LC antenna is easy to implement and to tune thanks to the integrated programmable capacitance. The internal sensor allows monitoring the temperature without external component.

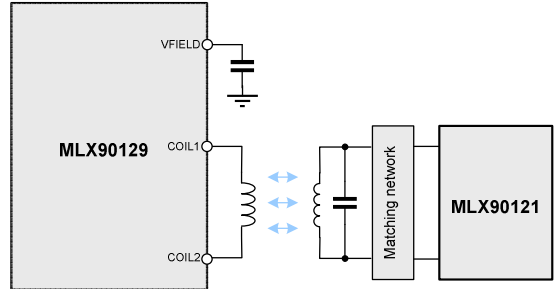

2. RFID multi sensors tag

Thanks to the multi sensor interface of the MLX90129, two differential sensors can be added. In this configuration 3 sensor values can be read by RFID.

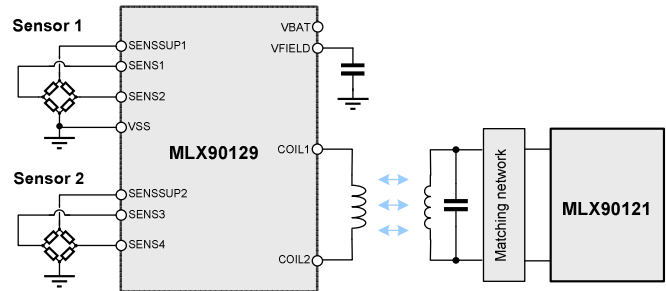

3. Data logger

The MLX90129 may be used in a standalone way as a data logger. The data may be stored in the internal EEPROM or in an external serial SPI EEPROM. Using the *automatic logging mode*, the MLX90129 wakes-up each programmed time period, converts the sensor data and stores it in the selected memory. This process may be hold or stopped by an external SPI master (microcontroller,...) or a RFID base-station. The data stored in EEPROM may be read via RFID.

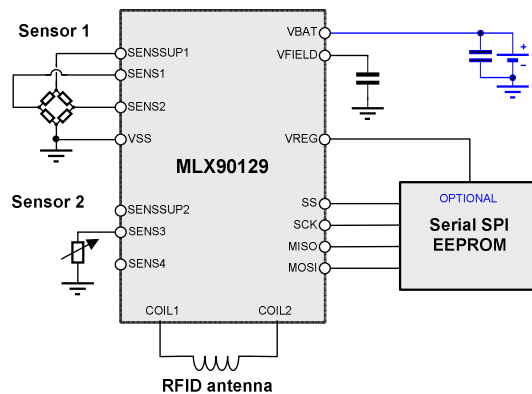

4. Micro-controller based applications

Numerous flexible applications using a microcontroller can be imagined. The microcontroller may manage the MLX90129 to sense, store or send the data via RFID. It may also control a RF transceiver as the TH7122 and an external non-volatile memory or a LCD.

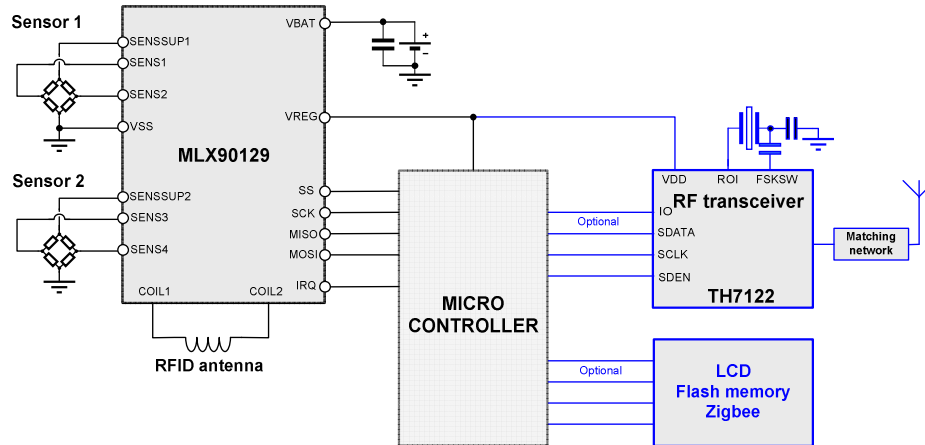

5. Padlock application

When the event detection system is enabled, a padlock may be made with a wire connected between the pins AT and VSS. If this wire is broken, this event is memorized, and an interrupt can (optionally) be sent to the external microcontroller. Instead of the wire, a light sensor (solar cell) may be connected. When powered, it sets an IRQ to the controller.

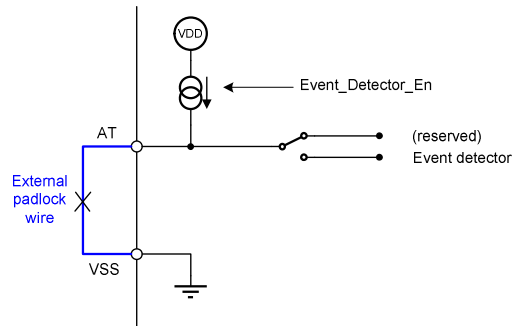

6. Serial resistor connected to the external sensor(s)

Numerous connections are possible between the external sensor and the internal resistors. The following figure shows an example of these possibilities.

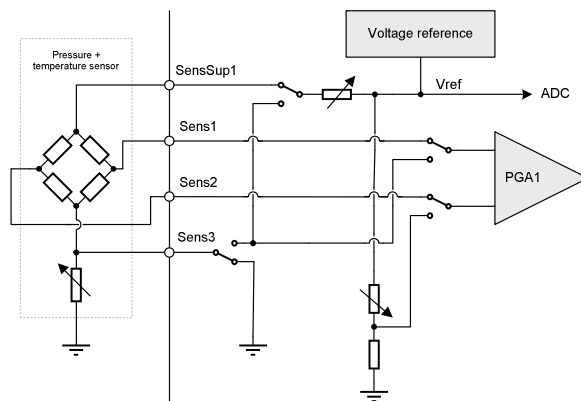

11 Reliability Information

Standard information regarding manufacturability of Melexis products with different soldering processes

Our products are classified and qualified regarding soldering technology, solderability and moisture sensitivity level according to following test methods:

Reflow Soldering SMD's (Surface Mount Devices)

- IPC/JEDEC J-STD-020
Moisture/Reflow Sensitivity Classification for Nonhermetic Solid State Surface Mount Devices (classification reflow profiles according to table 5-2)
- EIA/JEDEC JESD22-A113
Preconditioning of Nonhermetic Surface Mount Devices Prior to Reliability Testing (reflow profiles according to table 2)

Wave Soldering SMD's (Surface Mount Devices) and THD's (Through Hole Devices)

- EN60749-20
Resistance of plastic- encapsulated SMD's to combined effect of moisture and soldering heat
- EIA/JEDEC JESD22-B106 and EN60749-15
Resistance to soldering temperature for through-hole mounted devices

Iron Soldering THD's (Through Hole Devices)

- EN60749-15
Resistance to soldering temperature for through-hole mounted devices

Solderability SMD's (Surface Mount Devices) and THD's (Through Hole Devices)

- EIA/JEDEC JESD22-B102 and EN60749-21
Solderability

For all soldering technologies deviating from above mentioned standard conditions (regarding peak temperature, temperature gradient, temperature profile etc) additional classification and qualification tests have to be agreed upon with Melexis.

The application of Wave Soldering for SMD's is allowed only after consulting Melexis regarding assurance of adhesive strength between device and board.

Melexis is contributing to global environmental conservation by PROMoting **lead free** solutions. For more information on qualifications of **RoHS** compliant products (RoHS = European directive on the Restriction Of the use of certain Hazardous Substances) please visit the quality page on our website: <http://www.melexis.com/quality.aspx>.

12 ESD Precautions

Electronic semiconductor products are sensitive to Electro Static Discharge (ESD). Always observe Electro Static Discharge control procedures whenever handling semiconductor products.

13 Package Information

TSSOP20:

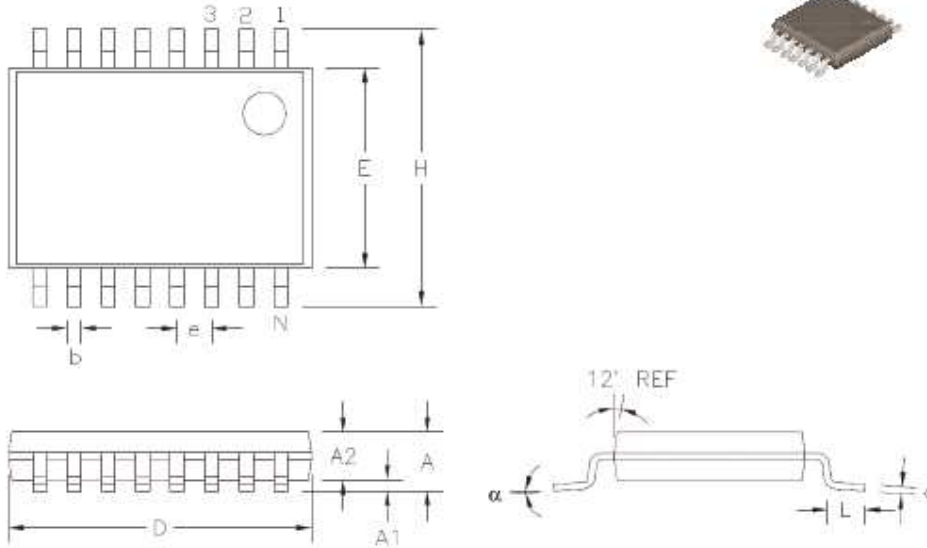

This table in mm

N		A	A1	A2	D	E	H	L	b	c	e	α
8	min	–	0.05	0.85	2.90	4.30	6.40	0.50	0.19	0.09	0.65	0°
	max	1.10	0.15	0.95	3.10	4.50	BSC	0.75	0.30	0.20	BSC	8°
14	min	–	0.05	0.85	4.90	4.30	6.40	0.50	0.19	0.09	0.65	0°
	max	1.10	0.15	0.95	5.10	4.50	BSC	0.75	0.30	0.20	BSC	8°
16	min	–	0.05	0.85	4.90	4.30	6.40	0.50	0.19	0.09	0.65	0°
	max	1.10	0.15	0.95	5.10	4.50	BSC	0.75	0.30	0.20	BSC	8°
20	min	–	0.05	0.85	6.40	4.30	6.40	0.50	0.19	0.09	0.65	0°
	max	1.10	0.15	0.95	6.60	4.50	BSC	0.75	0.30	0.20	BSC	8°
24	min	–	0.05	0.85	7.70	4.30	6.40	0.50	0.19	0.09	0.65	0°
	max	1.10	0.15	0.95	7.90	4.50	BSC	0.75	0.30	0.20	BSC	8°
28	min	–	0.05	0.85	9.60	4.30	6.40	0.50	0.19	0.09	0.65	0°
	max	1.10	0.15	0.95	9.80	4.50	BSC	0.75	0.30	0.20	BSC	8°

14 Disclaimer

- 1) The information included in this documentation is subject to Melexis intellectual and other property rights. Reproduction of information is permissible only if the information will not be altered and is accompanied by all associated conditions, limitations and notices.
- 2) Any use of the documentation without the prior written consent of Melexis other than the one set forth in clause 1 is an unfair and deceptive business practice. Melexis is not responsible or liable for such altered documentation.
- 3) The information furnished by Melexis in this documentation is provided 'as is'. Except as expressly warranted in any other applicable license agreement, Melexis disclaims all warranties either express, implied, statutory or otherwise including but not limited to the merchantability, fitness for a particular purpose, title and non-infringement with regard to the content of this documentation.
- 4) Notwithstanding the fact that Melexis endeavors to take care of the concept and content of this documentation, it may include technical or factual inaccuracies or typographical errors. Melexis disclaims any responsibility in connection herewith.
- 5) Melexis reserves the right to change the documentation, the specifications and prices at any time and without notice. Therefore, prior to designing this product into a system, it is necessary to check with Melexis for current information.
- 6) Melexis shall not be liable to recipient or any third party for any damages, including but not limited to personal injury, property damage, loss of profits, loss of use, interrupt of business or indirect, special incidental or consequential damages, of any kind, in connection with or arising out of the furnishing, performance or use of the information in this documentation.
- 7) The product described in this documentation is intended for use in normal commercial applications. Applications requiring operation beyond ranges specified in this documentation, unusual environmental requirements, or high reliability applications, such as military, medical life-support or life-sustaining equipment are specifically not recommended without additional processing by Melexis for each application.
- 8) Any supply of products by Melexis will be governed by the Melexis Terms of Sale, published on www.melexis.com.

© Melexis NV. All rights reserved.

For the latest version of this document, go to our website at:

www.melexis.com

Or for additional information contact Melexis Direct:

Europe, Africa:	Americas:	Asia:
Phone: +32 1367 0495	Phone: +1 603 223 2362	Phone: +32 1367 0495
E-mail: sales_europe@melexis.com	E-mail: sales_usa@melexis.com	E-mail: sales_asia@melexis.com