



Bluetooth® Module – LM-071 Class 2 BC04

Features

- The module is a Max 4dBm (Class2) module.
- Bluetooth standard v2.0 + EDR specification
- Low current consumption :
Hold, Sniff, Park, Deep Sleep Mode
- 3.0V to 3.6V operation
- Support for up to 7 ACL links and 3 SCO links (HCI mode firmware)
- Interface: USB, UART & PCM (for VOICE CODEC)
- SPP firmware available by default. Also offered HID firmware
- Support for 802.11 Co -Existence
- RoHS compliant
- External Antenna
- Small outline. 25 x 14.5 x 2.2 mm



Applications

- Serial Communications
- Cordless handset
- Digital camera & printer
- Embedded Devices
- Access Points
- GPS, POS, Barcode Reader
- Domestic and industrial applications

General Electrical Specification

Parameter	Description	Min.	Typ.	Max.	Units
Operating Voltage (VDD)	-	3.00	3.30	3.60	V
RF Output Power	Measured in 50 ohm	-6	0	4	dBm
RX Sensitivity	-	-	-83	-80	dBm
Input Low Voltage	RESET,UART,GPIO,PCM	-0.30	-	0.80	V
Input High Voltage	RESET,UART,GPIO ,PCM	0.70VDD	-	VDD+ 0.30	V
Output Low Voltage	UART,GPIO ,PCM	-	-	0.40	V
Output High Voltage	UART,GPIO ,PCM	VDD -0.40	-	-	V
Average Current Consumption	Deep sleep	-	40	-	uA
Average Current Consumption	ACL 40ms sniff	-	2.4	-	mA
Average Current Consumption	SCO connection HV1	-	39	-	mA
Peak Current	Tx burst + 4dBm	-	-	58	mA



Block Diagram

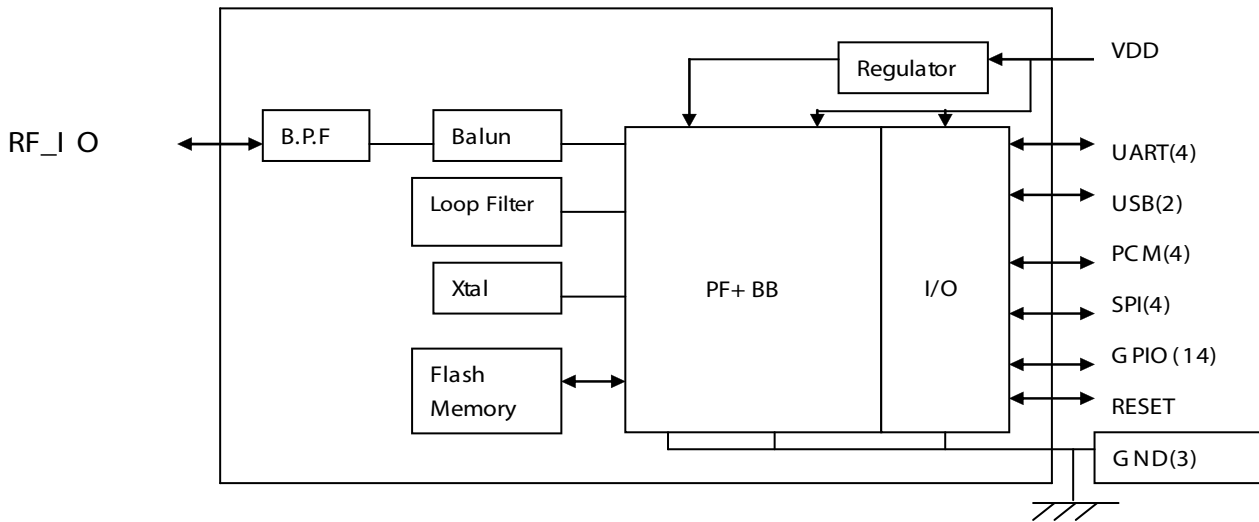

LM-071 Pin Functions

PIN	NAME	TYPE	FUNCTION
1	PIO(8)	Bi-directional	Programmable Input /Output line
2	PIO(9)	Bi-directional	Programmable Input /Output line
3	PIO(10)	Bi-directional	Programmable Input /Output line
4	AIO(0)	Bi-directional	Programmable Input /Output Line , 32KHz sleep clock input
5	AIO(1)	Bi-directional	Programmable Input /Output Line , 32KHz sleep clock input
6	RESET	CMOS input	Reset if high. Input debounced so must be high for >5ms to cause a reset
7	SPI_MISO	CMOS Output	Serial Peripheral Interface Data Output
8	SPI_CSB	CMOS Input	Chip Select For Synchronous Serial Interface active low
9	SPI_CLK	CMOS Input	Serial Peripheral Interface Clock
10	SPI_MOSI	CMOS Input	Serial Peripheral Interface Data Input
11	UART_CTS	CMOS Input	UART Clear To Send (Active Low)
12	UART_TX	CMOS Output	UART Data Output
13	UART_RTS	CMOS Output	UART Request To Send (Active Low)
14	UART_RX	CMOS Input	UART Data Input
15	PIO(11)	Bi-directional	Programmable Input/Output line
16	3V3	Power	3.3V Power Supply Input
17	GND	GND	Ground
18	PCM_OUT	CMOS Output	Synchronous Data Output
19	PCM_SYNC	Bi-directional	Synchronous Data Sync
20	PCM_IN	CMOS Input	Synchronous Data Input
21	PCM_CLK	Bi-directional	Synchronous Data Clock
22	USB_DP	Bi-directional	USB Data Plus
23	USB_DN	Bi-directional	USB Data Minus
24	PIO(7)	Bi-directional	Programmable Input /Output line
25	PIO(6)	Bi-directional	Programmable Input /Output line , CLK_REQ , WLAN_Active /Ch_Data input
26	PIO(5)	Bi-directional	Programmable Input /Output line , USB_DETACH, BT_Active output
27	PIO(4)	Bi-directional	Programmable Input / Output Line , USB_ON, BT_Priority /Ch_Clk Output
28	PIO(3)	Bi-directional	Programmable Input/Output Line , USB_WAKE_UP, CLK_REQ_IN



29	PIO(2)	Bi-directional	Programmable Input / Output Line , USB_PULL_UP, CLK_REQ_OUT
30	PIO(1)	Bi-directional	Programmable Input/Output Line , TX Enable
31	PIO(0)	Bi-directional	Programmable Input / Output Line , RX Enable
32	GND	GND	Ground
33	RF_IO	Analogue	50 ohm Antenna connection
34	GND	GND	Ground

LM-071 Pin out Information

PIN DETAILS VIEWED FROM TOP SIDE

1	34
PIO (8)	GND
PIO (9)	RF_IO
PIO (10)	GND
AIO (0)	PIO (0)
AIO (1)	PIO (1)
RESET	PIO (2)
SPI_MISO	PIO (3)
SPI_CSB	PIO (4)
SPI_CLK	PIO (5)
SPI_MOSI	PIO (6)
UART_CTS	PIO (7)
UART_TX	USB_DN
UART_RTS	USB_DP
UART_RX	PCM_CLK
PIO (11)	PCM_IN
3V3	PCM_SYNC
GND	PCM_OUT
17	18

MODULE PAD AND SOLDER MASK DETAILS

SOLDER MASK WINDOW 1.0mm MAX
SOLDER PAD 0.8mm



MECHANICAL DETAILS VIEWED FROM TOP/BOTTOM SIDE

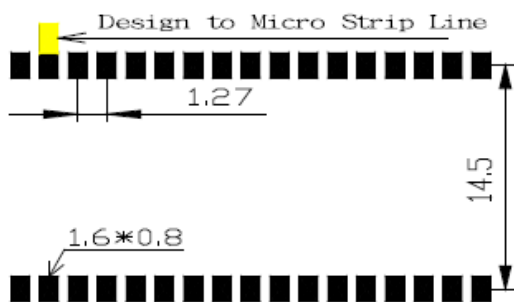
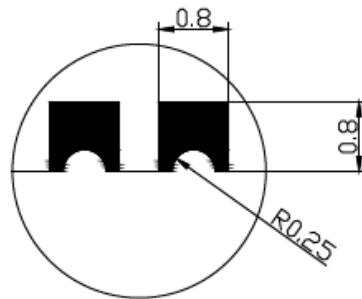
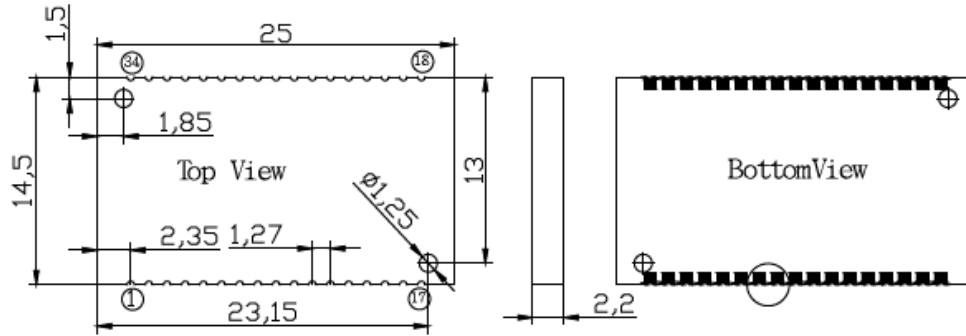



LM071 Antenna Circuit Values

C1	NC/0603	0.1UF,16V,+80-20%,Y5V,0603	CHIP/C
C2	NC/0603	0.1UF,16V,+80-20%,Y5V,0603	CHIP/C
L4	OR/0603	0R,1/10W,+/-5%,0603	CHIP/R

Application Schematic

