

COUNT	DESCRIPTION OF REVISIONS	BY	CHKD	DATE	COUNT	DESCRIPTION OF REVISIONS	BY	CHKD	DATE
△				..	△				..
△				..	△				..
△				..	△				..

A
B
C
D
E
F

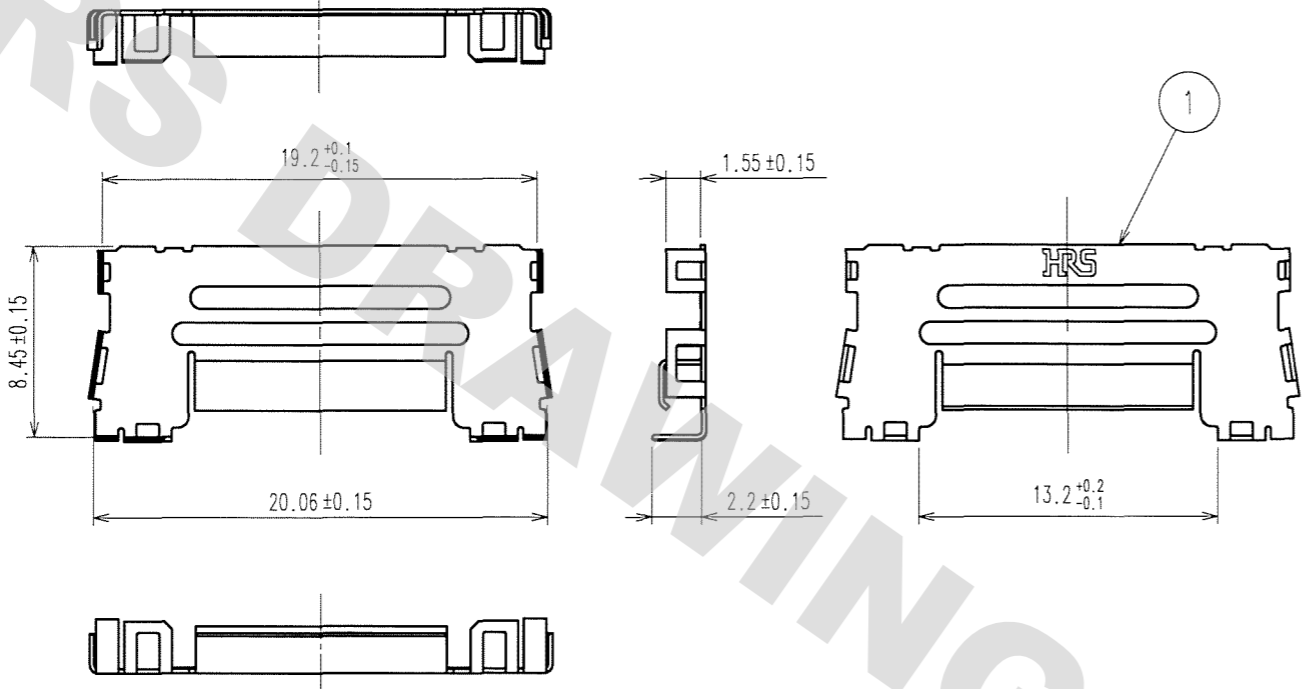

DETAILED FIGURE OF REEL (FREE)

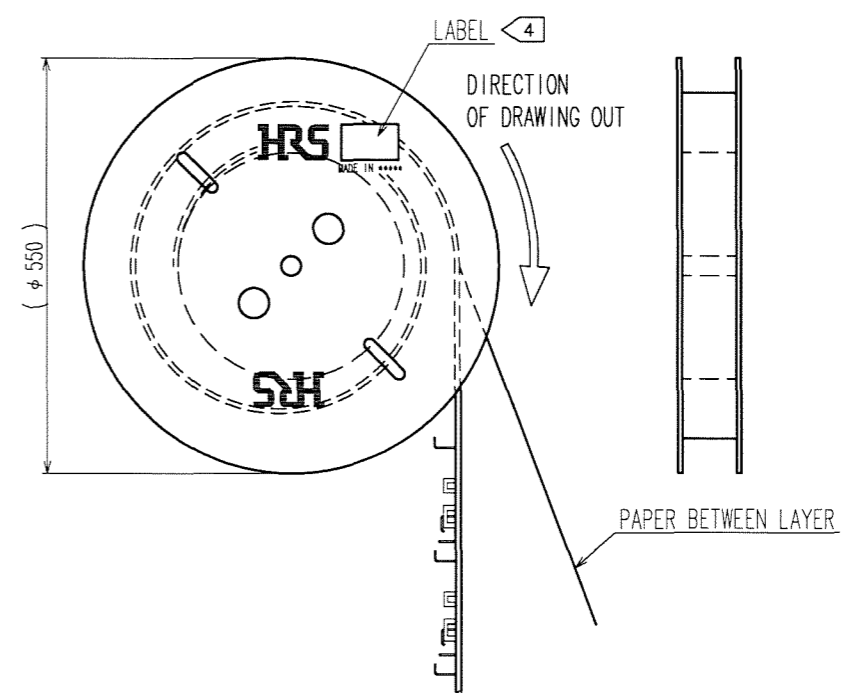

DETAILED FIGURE OF CAREER (2 : 1)

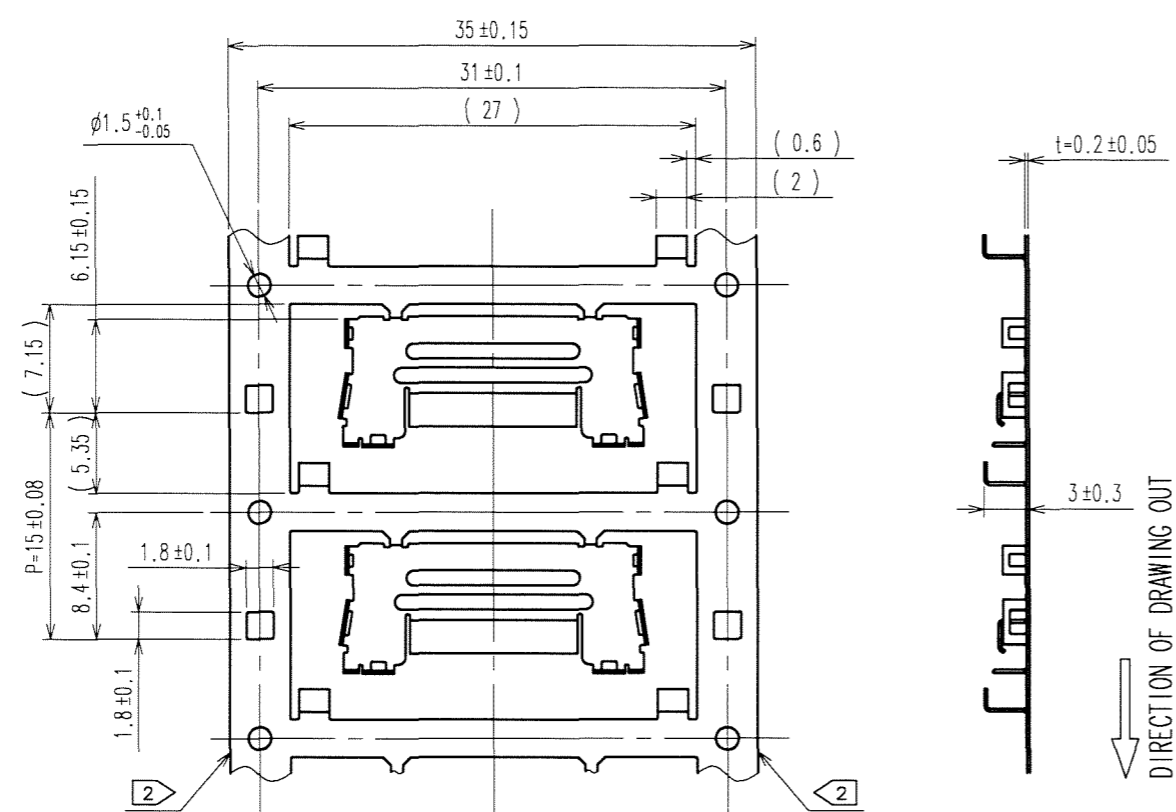

- NOTE 1. MANUFACTURING PROCESS COULD LEAVE SCRATCH AND/OR PUNCH MARKS HAVING NO AFFECT ON THE PRODUCT PERFORMANCE.
 2. SIDE CUT CAN BE PROVIDED TO PREVENT CARRIER CURVE.
 3. 2500 PIECES PER REEL.
 4. LABEL AS SHOWN BELOW IS INDICATED.

HRS		INSPECTION 検査
CODE No. 品名コード	CL575-3211-6	
PART NO. 品名	FX16-21P-GND(A)	
QTY 数量	2,500 PCS	
PECULIAR 仕様		
Lot No		
SPLICE 継ぎ目		

5. DIMENSION IN () ARE FOR REFERENCE.
 6. THIS IS A COMPONENT FOR SEPARATELY AVAILABLE PRODUCT;FX16-21P-0.5FC OR FX16-21P-0.5SD. WHEN FFC IS USED FOR THE CABLE, MAKE SURE TO USE WITH THE SPECIFIED COMBINATION.

NO.	MATERIAL	FINISH, REMARKS	NO.	MATERIAL	FINISH, REMARKS
			1	STAINLESS	
CODE NO. (OLD) CL			DRAWN	DESIGNED	CHECKED
			K. SHIBUYA	K. Shibuya	K. Yamayachi
			08.01.24	08.01.25	08.01.25
APPROVED	RELEASED				
SCALE FREE	DRAWING NO. EDC3-157529	PART NO. FX16-21P-GND(A)			
UNITS mm	HRS HIROSE ELECTRIC CO., LTD	CODE NO. CL575-3211-6			

DRAWING FOR REFERENCE: This is subject to change without notice
 08/11/2012

TO