

BMA220

Digital, triaxial acceleration sensor

Bosch Sensortec



BOSCH

Invented for life

General description

The BMA220 is an ultra small triaxial, low-g acceleration sensor with digital interfaces, aiming for low-power consumer market applications.

The BMA220 allows measurement of accelerations in 3 perpendicular axes and thus senses tilt, motion, shock and vibration in cell phones, handhelds, computer peripherals, man-machine interfaces, virtual reality features and game controllers.

BMA220 target applications

- ▶ Display profile switching (e.g. portrait/landscape)
- ▶ Tap sensing function
- ▶ Menu scrolling
- ▶ Gaming
- ▶ Advanced power management for mobile devices
- ▶ Shock detection

Sensor operation

With its size of only 2 mm x 2 mm the BMA220 represents a new generation of digital acceleration sensors. The BMA220 integrates a multitude of features that facilitates its use especially in the area of motion detection applications, such as device orientation detection, gaming, HMI and menu browser control.

The BMA220 is highly configurable in order to give the designer full flexibility when integrating the sen-

sor into his system. All features can be set by software via the digital interface. This implies also that even once a hardware platform with the BMA220 exists, it can be modified by software in order to expand the capabilities and use cases.

As already introduced with the successful BMA150 and SMB380 digital acceleration sensors, also for the BMA220 the g-ranges, bandwidths and interrupt parameters can be user programmed via the serial digital interface. Here the user can choose between I²C and SPI (3-wire/4-wire) interface modes.

One of the key elements of the BMA220 is the intelligent interrupt engine that gives the hard- and software designer full control. Various motion detection scenarios can be identified by the BMA220 and signaled to the system via a simple interrupt pin.

Key features BMA220

- ▶ User programmable g-range and bandwidth
- ▶ Low-power consumption
- ▶ SPI (3-wire/4-wire) and I²C interface
- ▶ User programmable interrupt engine
- ▶ Ultra-low-power auto-wake-up mode
- ▶ Self-test capability
- ▶ Ultra small package
- ▶ RoHS compliant, halogen-free

BMA220	Technical data
Sensitivity axes	x/y/z
Measurement range	±2g, ±4g, ±8g, ±16g (switchable via SPI/I ² C)
Sensitivity (calibrated)	±2g: 16 LSB/g ±4g: 8 LSB/g ±8g: 4 LSB/g ±16g: 2 LSB/g
Resolution	6 bit ⇒ 62.5 mg (±2g range)
Nonlinearity	±2% FS
Zero-g offset	±95 mg
Bandwidth	1 kHz ... 32 Hz (switchable via SPI/I ² C)
Digital input / output	SPI & I ² C, interrupt pin
Supply voltage	1.8V
I/O supply voltage	1.62V ... 3.6V
Temperature range	-40°C ... +85°C
LGA package	2 x 2 x 0.98 mm ³

BMA220 Pin configuration (top view)

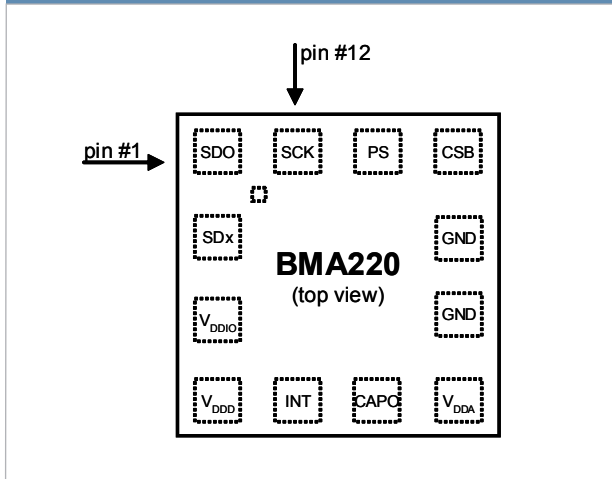

Pin No.	Name	Function
1	SDO	SPI serial data output
2	SDx	I ² C / SPI serial data in/out (SDI, SDA, SDO)
3	V _{DDIO}	I/O supply voltage (1.62 ... 3.6V)
4	V _{DDD}	Digital supply voltage (1.8V)
5	INT	Interrupt output
6	DNC	Do not connect!
7	V _{DDA}	Analog supply voltage
8	GND	Shared ground
9	GND	Shared ground
10	CSB	SPI chip select
11	PS	I ² C / SPI select pin
12	SCK	SCL (I ² C serial clock) SCK (SPI serial clock)

By using the digital serial interface, the exact details of the motion event that triggered the interrupt can be read-out.

Following motion detection use case scenarios are supported by the interrupt engine:

- ▶ Any-motion (slope) detection
- ▶ Tap sensing
- ▶ Orientation change recognition
- ▶ Low-g / high-g detection
- ▶ Data-ready
- ▶ Self-wake-up

The interrupts can be conveniently configured by the user and thus perfectly support the integration of the BMA220 into the user's system environment.

Another important feature of the BMA220 acceleration sensor is the power management module. This module allows optimizing the sensor's power consumption in-line with the specific user requirements. Thus, it is not necessary to operate the sensor at full power for all application scenarios all the time. For some use cases the power consumption drastically shrinks to just a fraction of what would be required in full performance mode.

Moreover this feature of the BMA220 allows for an intelligent system power management and thus significant reduction of the whole system's power consumption. In particular, this helps increasing battery life-time of any kind of mobile device.

In the unique „dedicated I/O“ modes the BMA220 can be operated as a stand-alone device without requiring a μ Controller.

**Headquarters
Bosch Sensortec GmbH**

Gerhard-Kindler-Strasse 8
72770 Reutlingen · Germany
Telephone +49 7121 3535 900
Fax +49 7121 3535 909
contact@bosch-sensortec.com
www.bosch-sensortec.com