



AA.105.301111

Specification

Part No.	AA.105.301111
Product Name	Titan GPS Antenna AA.105
Feature	<ul style="list-style-type: none"> Magnetic Mount Covert stylish design Wide band input voltage Gain can be adjusted for your application (10dB~31dB) IP-67 Waterproof 3M RG174 SMA (M) Straight Cable and connector customizable RoHS Compliant

1. Introduction

Our AA.105 Titan magnetic mount external antenna is ideal for robust, covert installations where durability and small size is paramount.

It is used in telematics and M2M applications, for example in commercial vehicle installations for fleet management. It is fully waterproof to IP67 rating.

Standard cable and connector version is 3 metre RG174 and SMA(M). Cable length and connector type are customizable upon request.

2. Electrical Specifications

2.1 Ceramic Patch Specification

Parameter	Specification
Outline Dimension	25*25*4mm
Ground Size	25*25*4mm
Center Frequency	1575.42±3MHz
Bandwidth	10MHz
VSWR	1.92 Max
Axial ratio	3dB Typ.
Gain @ Zenith	2dBic Typ.
Impedance	50Ω
Polarization	RHCP

2.2 LNA Specification

Parameter	Specification
Frequency	1575.42MHz
Impedance	50Ω
VSWR	1.92 Max.
Gain	30dB Typ.
Gain at Connector*	28.4dB
DC Power Input	2.7~5V
Noise Figure	1.5dB Typ.
Power Consumption	4.7mA @ 2.7V 6mA @ 3.3V 10.3mA @ 5V
Operating temp	-40°C ~ +85°C
Storage Temp	-40°C ~ +90°C

*Formula = Patch Antenna Average Gain + LNA typical gain – RG174 cable loss @1.2dB per meter = Gain at connector
 Gain at the Connector - Patch Gain 2dB + LNA Gain 30dB – Cable loss of 1.2dB per metre
 (@3m = 3.6dB) = 28.4dB approx.

3. Ceramic Antenna S11 (with housing)

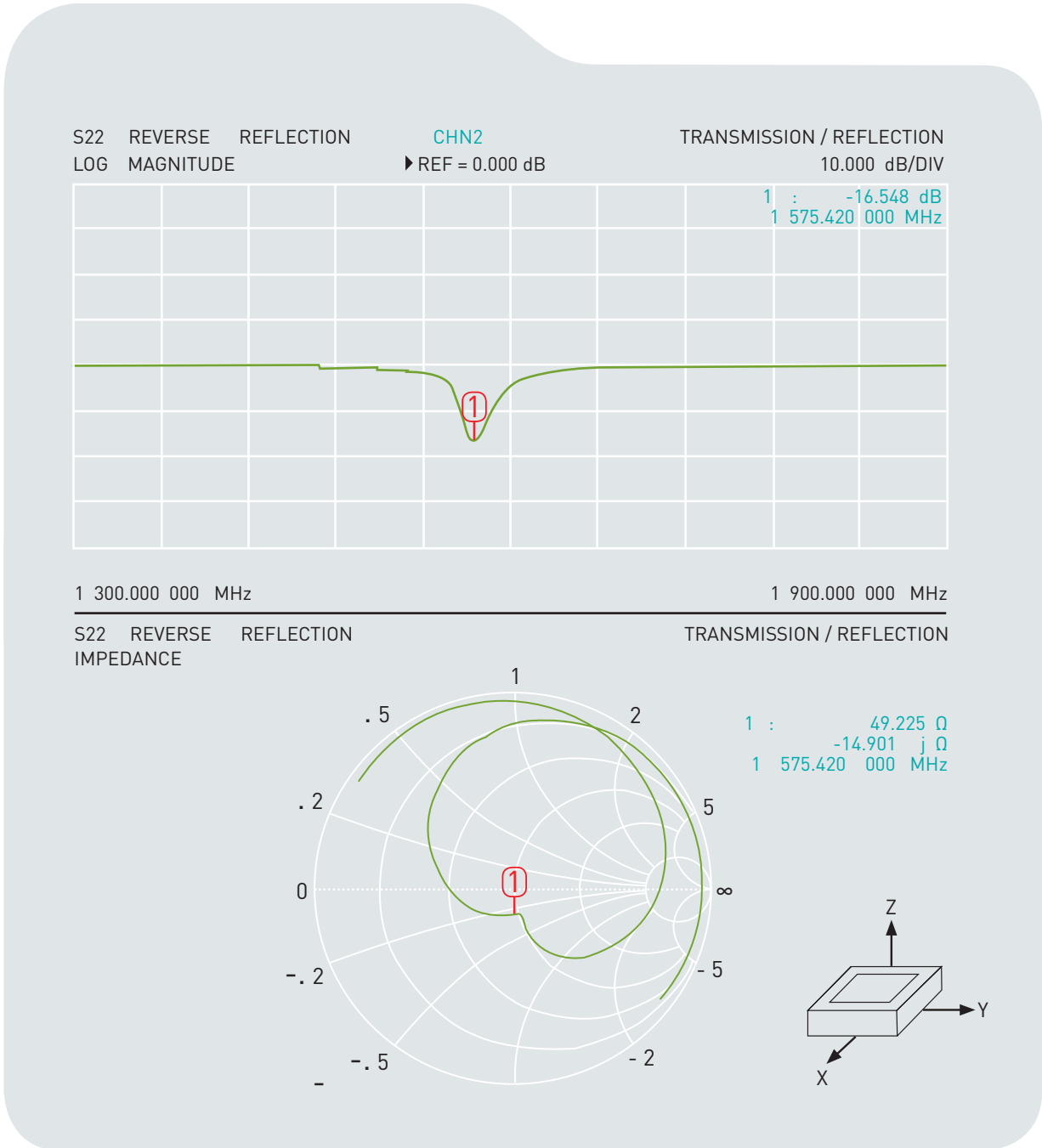

4. Ceramic Antenna Radiation Pattern (with housing)

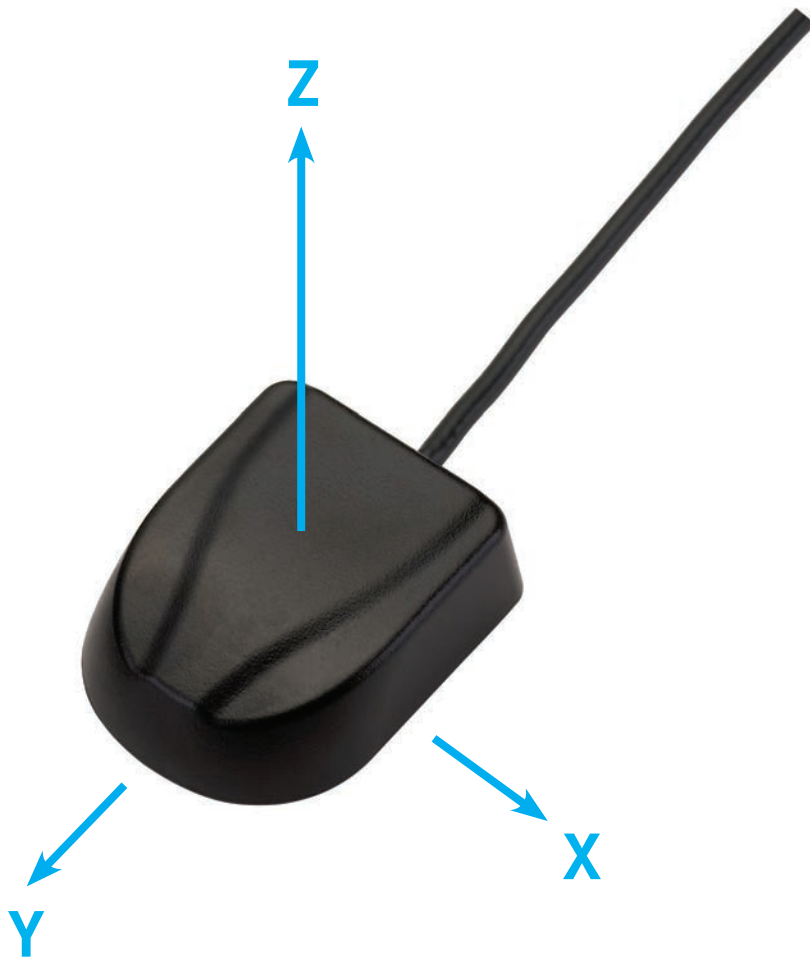

4.1 XZ Plane & YZ Plane

XZ Plane

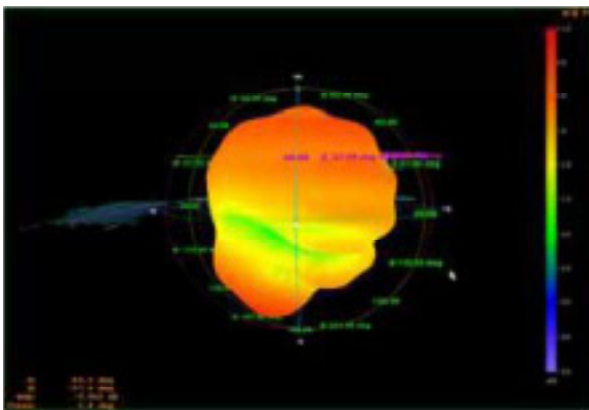

YZ Plane

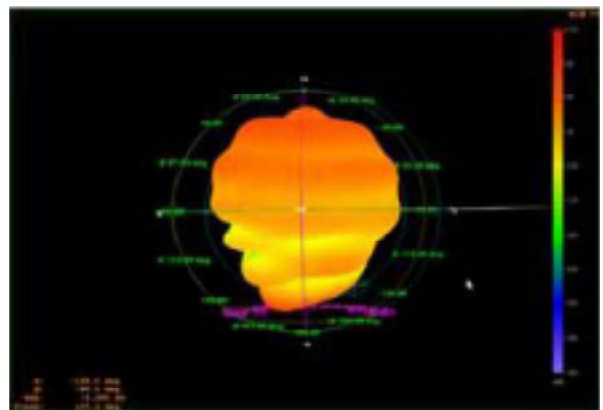

Far-field amplitude of goasial
1583 06-5-8.nsi

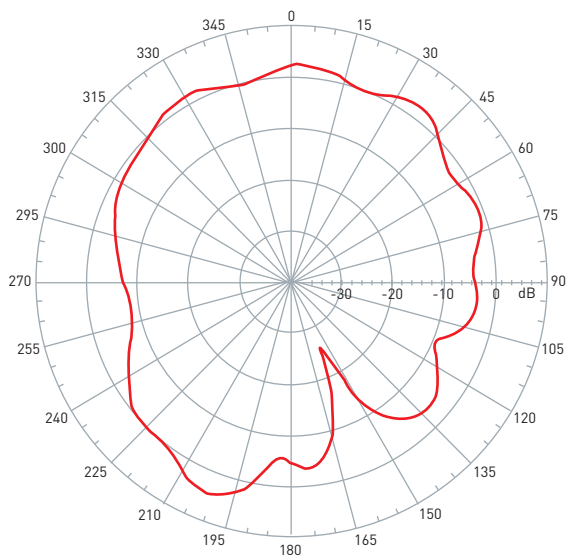

Far-field amplitude of goasial
1583 06-5-8.nsi

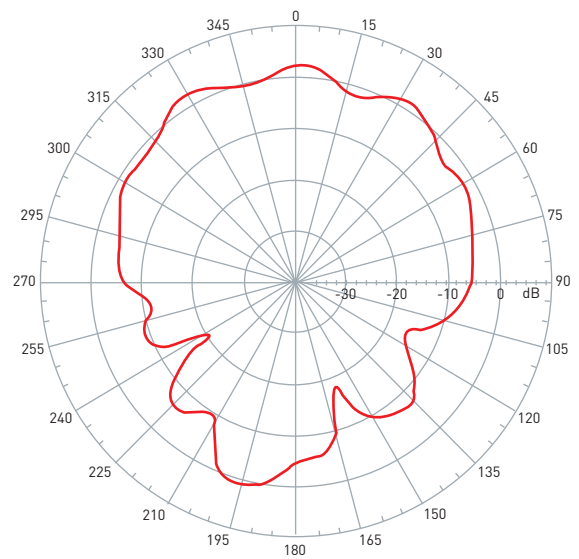

5. LNA gain

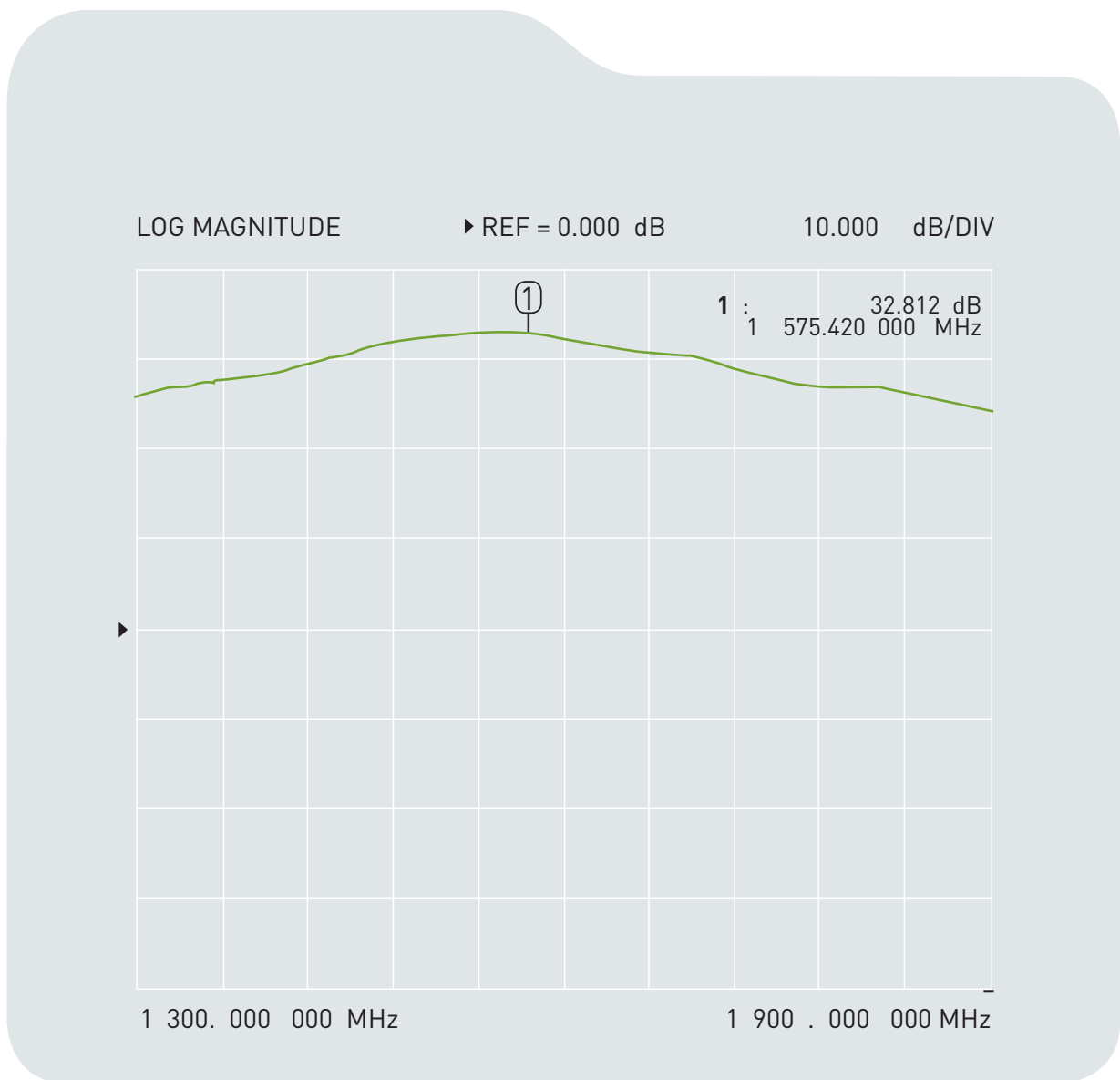

6. LNA S22

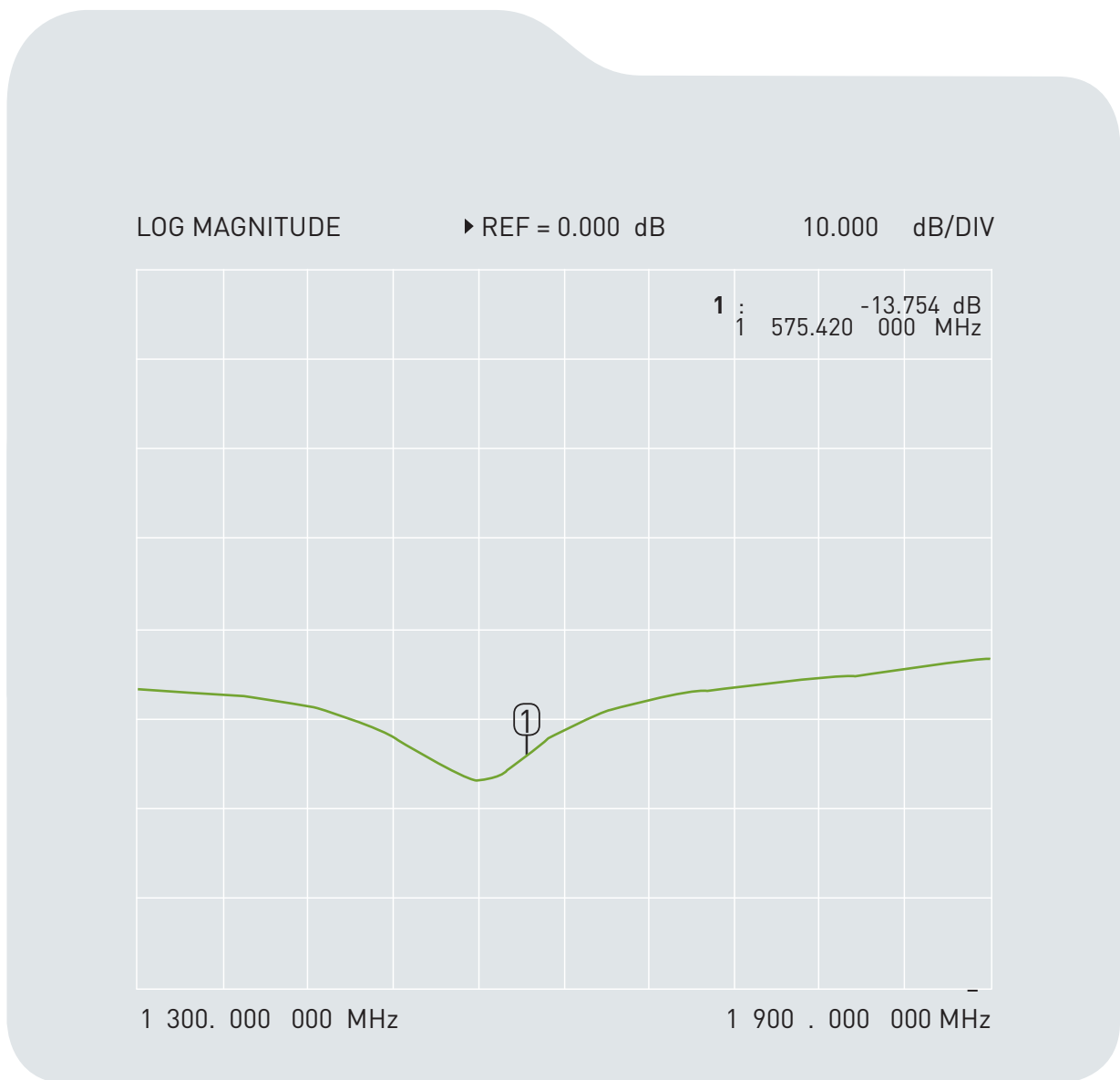

7. Antenna Field Trial Results

Antenna was connected to a U-blox EVK-6H evaluation kit under open sky conditions.

- **1.8 V**
Cold Start needs typically 40 seconds.

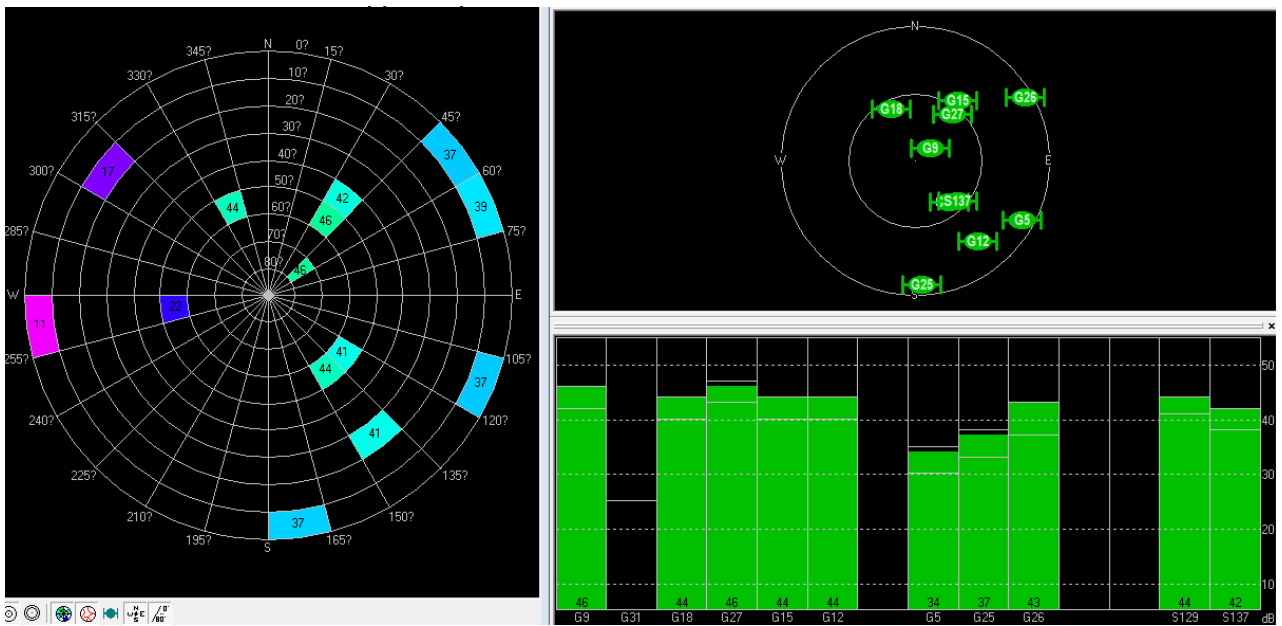

- **3.3 V**
Cold Start needs typically 40 seconds.

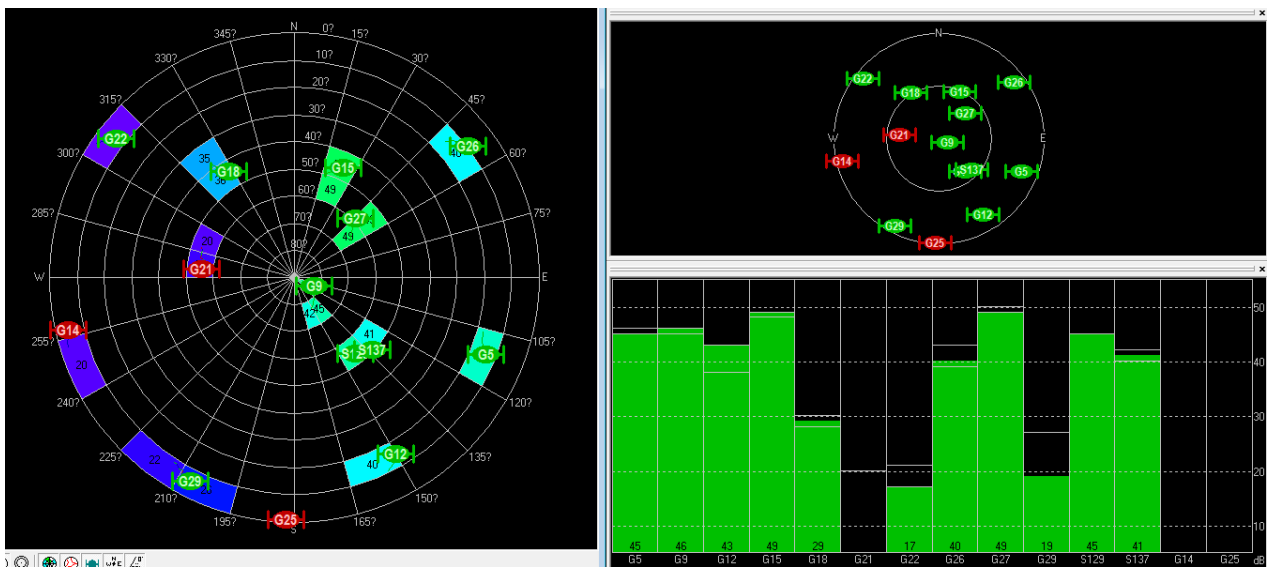

8. Drawing

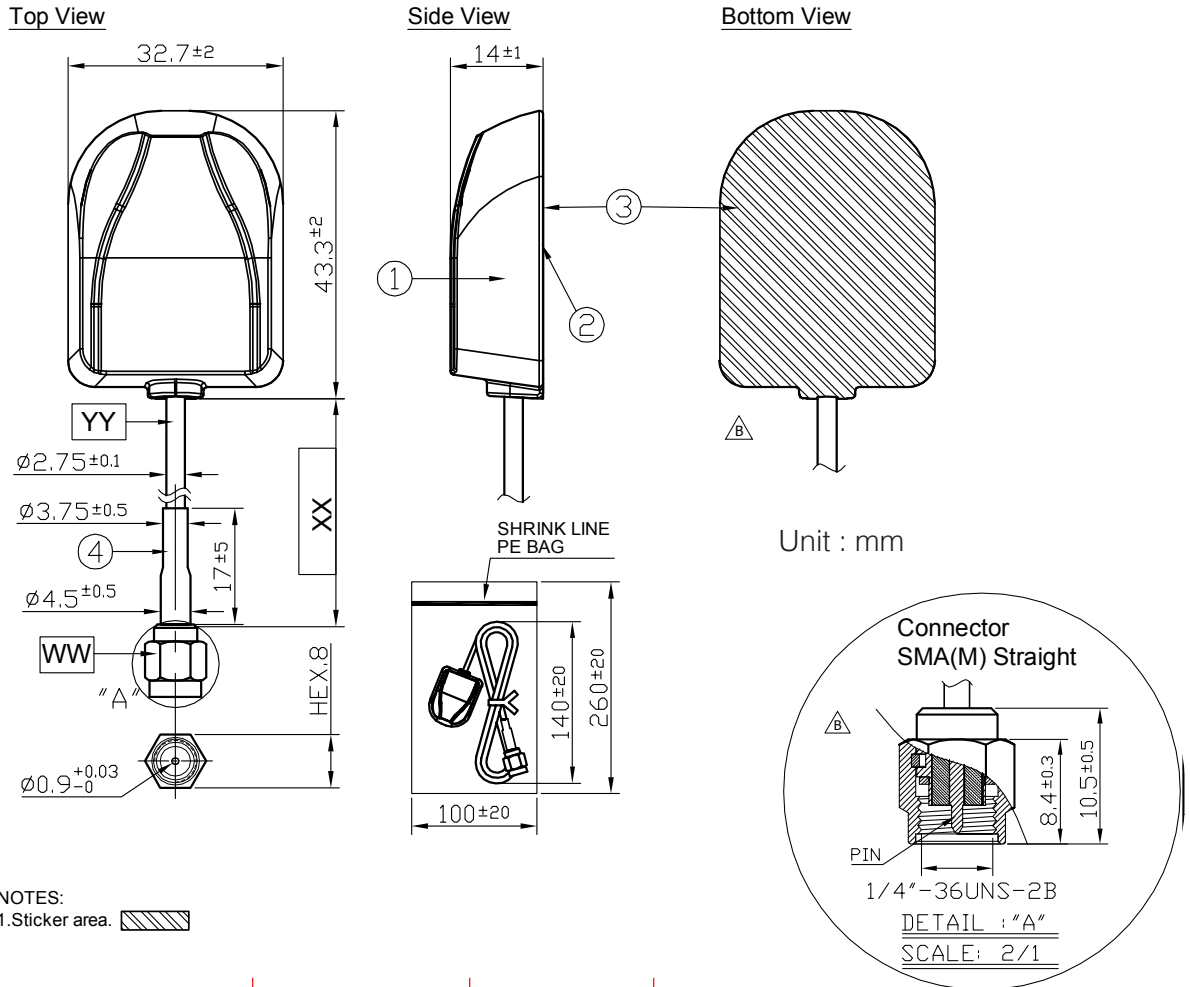

	Name	Material	Finish	QTY
1	GPS Antenna Top	PC	Black	1
2	GPS Antenna Bottom	PC	Black	1
3	Sticker 	Matte Silver PET	Silver	1
4	Heat Shrink Tube	PE	Black	1

	Name	Material	Finish	QTY
WW	Connector Type	SMA (M) Straight	Gold	1
XX	Cable Length	3000±30mm	Black	1
YY	Cable Type	RG174	Black	1

RG-174 cable attenuation (dB/100mm)

GHz	0.5	1	1.5	2	2.5	3	3.5	4	4.5	5	5.5	6
RG-174	67	110	127	153	168	183	207	229	252	272	291	311

9. Packaging

- 1pcs antenna per small PE bag
- 20 small PE bags per big PE bag
- 20pcs antennas per big PE bag

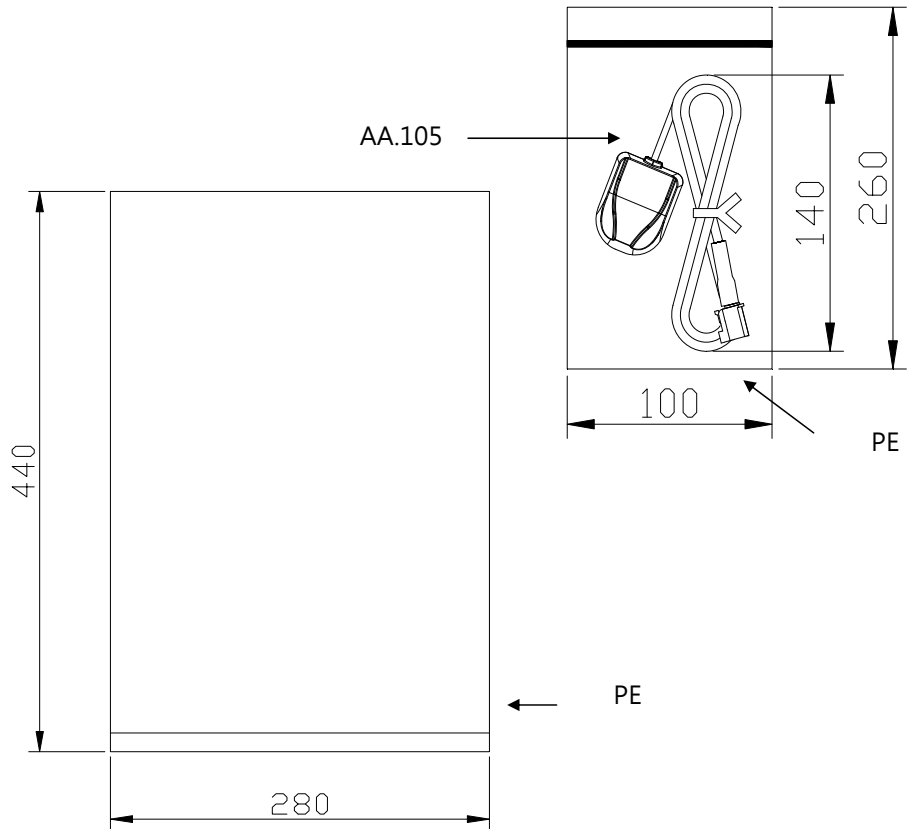

Unit : mm

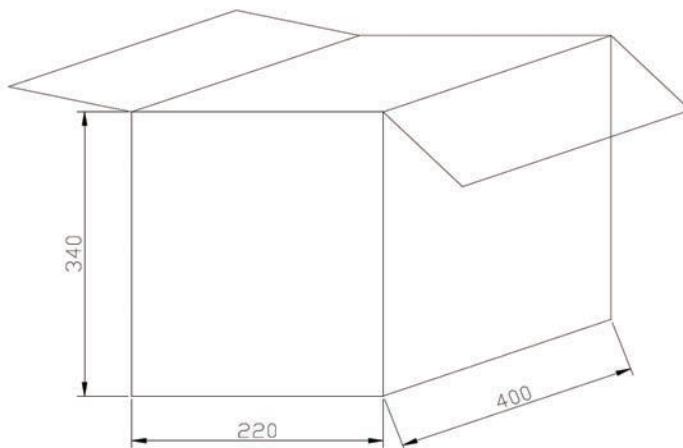

- 80 pieces per carton
- Carton Weight 6.5kg

Taoglas makes no warranties based on the accuracy or completeness of the contents of this document and reserves the right to make changes to specifications and

product descriptions at any time without notice.

Taoglas reserves all rights to this document and the information

contained herein. Reproduction, use or disclosure to third parties without express permission is strictly prohibited. Copyright © Taoglas Ltd.