

TECHNICAL CHARACTERISTICS

MATERIAL
 CONTACT MATERIAL: COPPER ALLOY
 CONTACT TYPE: STAMPED
 CONTACT PLATING: TIN
 QUALITY CLASS: 25 MATING CYCLES
 PITCH: FOR 1.25MM

ENVIRONMENTAL
 OPERATING TEMPERATURE: -25 UP TO 85°C
 COMPLIANCE: LEAD FREE AND ROHS

ELECTRICAL
 CURRENT RATING: 1A
 WORKING VOLTAGE: 50V AC
 CONTACT RESISTANCE: 20 mOHM MAX

WIRE DIMENSION
 AWG: AWG 28 - 30

PACKAGING
 15 KPCS REEL

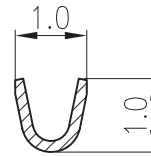
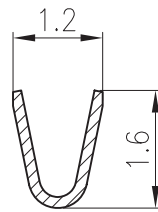
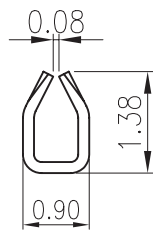

A-A

B-B

RoHS Compliant

| | | | |
|-----|-----------|-----------------|----|
| G | | | |
| F | 07-AUG-13 | CHARACTERISTIC | QL |
| E | 11-MAY-10 | PACKAGING | JP |
| D | 16-FEB-09 | DRAW | JP |
| C | 09-AUG-08 | T&R DESCRIPTION | RB |
| B | 02-MAR-08 | DRAW | EC |
| A | | PDF | JP |
| REV | DATE | FILE | BY |

PROJECTION:

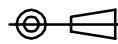

APPROVAL: RJ

GENERAL TOLERANCE

.X = ± 0.2

.XX = ± 0.15



UNIT: MM

SCALE:

SHEET: 1/2

DRAW: MIKE

DESCRIPTION: 1.25 MM FEMALE CRIMP TERMINAL

WERI PART NO: 65300113722

SIZE

A4

1

2

3

4

5

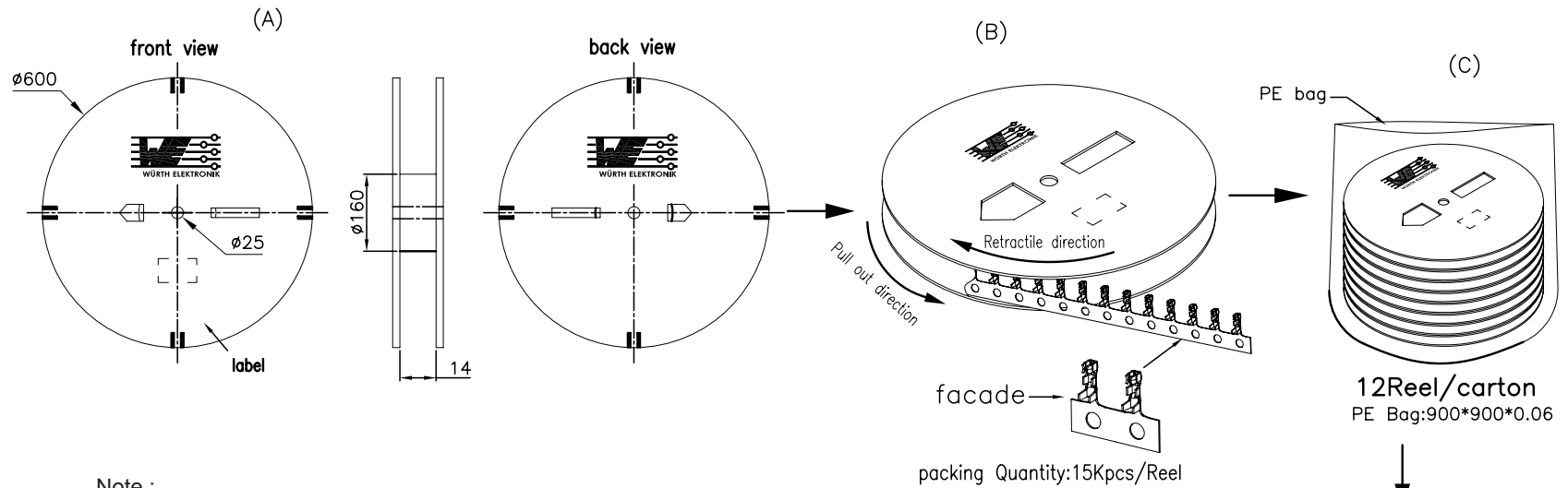

Note :

1. All dimensions meet EIA-481-3 requirements.
2. Material :WH Conductive polystyrene Alloy.
- 3.Thickness : 0.50±0.05mm.
- 4.Component load per reel : 15.000 pcs.
- 5.Reel size : diameters 160*25, T=14.
- 6.Reel chipboard size : diameters 600*25, T=14.
- 7.Bag size : 900*900*0.06.
- 8.Carton size : 615*615*340.

| Q'tY/Reel | Reel/Carton | Q'tY/Carton |
|-----------|-------------|-------------|
| 15Kpcs | 12 | 180Kpcs |

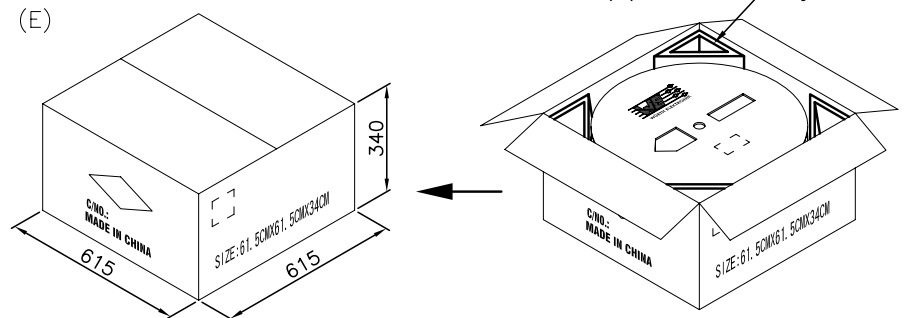

RoHS Compliant

| | | | | | | | | |
|-----|------|------|----|-----------------|---|---|-------------------|---------------------------|
| G | | | | PROJECTION: | GENERAL TOLERANCE .X = +/- 0.2 .XX = +/- 0.15 | | | |
| F | | | | | | | | |
| E | | | | | | | | |
| D | | | | | | | | |
| C | | | | APPROVAL: | UNIT: MM | DESCRIPTION: 1.25MM FEMALE TERMINAL CRIMP CONTACT | SIZE A4 | |
| B | | | | | SCALE: | | | |
| A | | | | | SHEET: 2/2 | | | WERI PART NO: 65300113722 |
| REV | DATE | FILE | BY | | DRAW: MIKE | | | |