

Wireless Development Kit – User Guide

Overview

EZURiO's Wireless Development Kit provides a platform for rapid prototyping of wireless connectivity, providing options for the development of Bluetooth, 802.11 and GPRS applications

1. Introduction

The EZURiO Wireless Development Kit is designed to support the rapid development of applications and software for the EZURiO range of Bluetooth and Wireless LAN modules. The development board will also allow you to develop applications and services for a Siemens MC55 GPRS module when connected to an external power supply.

Package Contents

All kits contain the following items	
Development Board	The mother board is used to mount your chosen wireless module, providing the RS232 interface and access to all the module interface pins.
USB cable	The USB cable can be used as one of the options to provide power for the dev kit via the onboard connector.
Serial cable	RS232 interface cable to provide the communication between your host pc and your choice of wireless module. The serial cable can also be used as an option to power the motherboard and module from pin 9.
Bluetooth USB adapter	Versions of the Development Kit which include a Bluetooth module include a FREE USB Bluetooth adaptor and Windows protocols stack.
Three Mounting Spacers	Mounting spacers for securing your choice of Bluetooth or Wireless LAN module to the motherboard
EZURiO terminal application	PC based terminal emulation software, specifically designed to help the development and diagnostics of applications on the EZURiO range of modules
Documentation	A development kit user guide, board design circuit diagrams and a quick start guide

2. Wireless Module Development Board

The development board allows the EZURiO Bluetooth or Wireless LAN Module to be connected to a PC. The development board provides RS-232 level conversion through a standard 9 way D type connector to all pins of the 40 way and a 50 way Hirose connectors used by Bluetooth or Wireless LAN modules.

A separate connector is provided for PCM audio for use with the 40 way EZURiO Bluetooth modules. This can be connected to a customer's own evaluation board or a range of codec accessory boards that EZURiO will make available.

3. Getting to know the Development Board

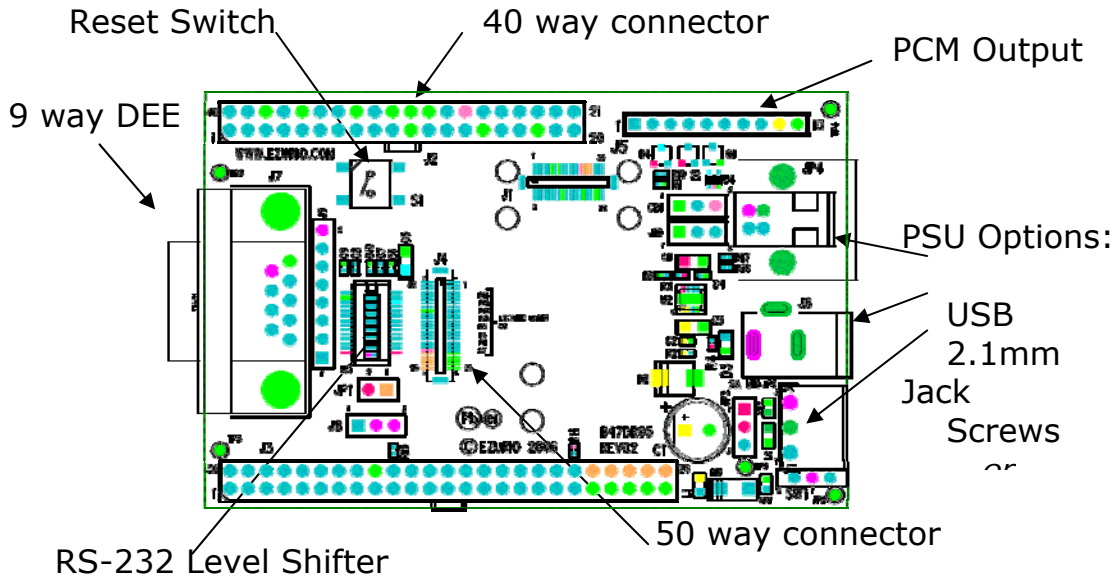

4. Power Supply

	Minimum	Typical	Maximum
Input Voltage	3.6V	5V	6V

The development board provides a number of options to provide power to the module.

- 5V Power from a USB port
- Power from an external power supply via screw terminals
- Power from an external mains power block via a 2.1mm DC connector
- Power via Pin 9 of the RS232 adaptor

The developer kit includes a USB cable to provide power to the development board. This should be plugged into a PC USB port, a USB hub, or a mains adaptor with a USB output. If a hub is used, it should be a powered USB hub to ensure that sufficient current is available at the port being used. Both the Bluetooth Intelligent Serial Module (BISMII) and the Wireless LAN (WISM) modules can be driven by the current available at a USB port.

When using a Siemens MC55 GPRS modem in the development board, an external power supply with a minimum current capacity of 2A **MUST** be used and connected to the power supply terminals.

Jumper JP2 is used to select an external power source on the screw terminals.

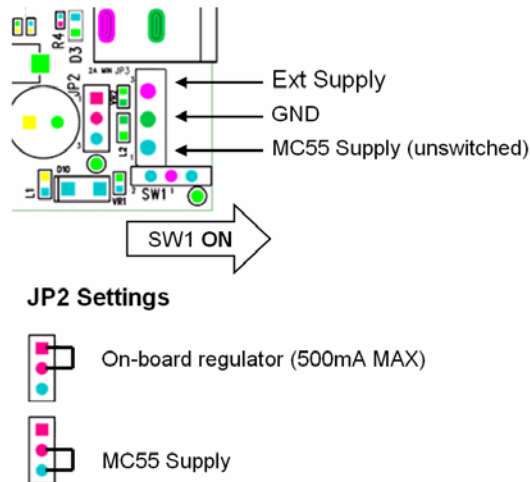

SW1 (slide switch) provides the power on / off for the module but does not isolate the power from other components of the development board.

S1 (push button TACT switch) provides a reset signal to both the 40 way and 50 way connectors. Note that the reset polarity is different for the 40 and 50 way pinouts. This is accomplished by circuitry on the development board, providing an active HIGH reset for the 40 way connector and an active LOW for the 50 way connector. Users connecting a reset signal to the test points on the board, should be aware that there is a 10kΩ pulldown on the 40 way reset pin, and an open collector transistor connected to the 50 way reset pin. Refer to the schematics on the CD.

An alternative method of powering the development kit is to supply power to Pin 9 of the RS232 connector. If this method is used, no other power supplies should be connected to the board. Jumper 8 on the development board needs to be moved to allow power to be derived from pin 9 of the serial port. In this mode the ring indicator will not be available from the RS232 interface.

J8 Settings

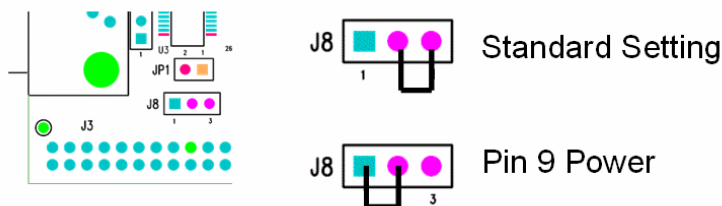

5. RS-232 Serial Interface

This provides a direct interface to any standard RS-232 port on a PC or peripheral. The 9 way D type connector can be plugged straight into a serial port on a PC or peripheral. If access to the serial port is restricted, the serial cable provided can be used to connect the development board to the PC.

The development board contains a level shifter on the RX, TX, CTS, RTS, DTR, DSR, RI and DCD signals that converts between the 3.3V levels required on the module to the standard RS-232 levels.

The level shifter can have its outputs permanently enabled, or enabled only when the module is active, i.e. not in sleep mode. The latter is useful when a defined state is required at the RS232 interface as the module enters and exits its low power modes. The behaviour is determined by the setting of J10, which is located behind the USB socket at the rear of the board. The normal setting is Always Enabled.

*Note that the 50 pin formats of the WISM and the Siemens MC55 do not support the output line to drive this input. When using modules on the 50 pin connector J10 **must** be set to Always Enabled.*

J10 Settings

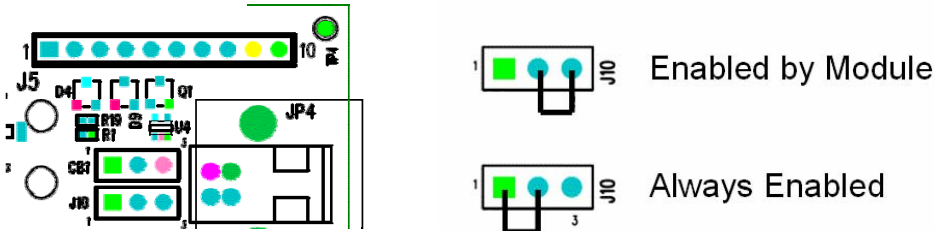

If digital signal levels are required at the RS232 connector, these can be achieved by removing the level shifter and populating the PCB pads that are then exposed with zero ohm links.

6. Software

The development board will connect any EZURiO Bluetooth or Wireless LAN Module to the serial port of a PC or other device. From a PC you can communicate with the module using any Terminal Emulator software such as HyperTerminal, Procomm or the EZURiO Terminal application supplied.

EZURiO Terminal is a terminal emulation application capable of running on Windows 98, Me, 2000 and XP operating systems. It was developed specifically to aid development and testing of EZURiO Modules. It allows connection to serial devices using any combination of the following communications parameters:

COM Port:	1 to 255
Baud rate:	300 to 921600
Parity:	None, Odd, Even
Data Bits:	7 or 8
Stop Bits:	1 or 2
Handshaking:	None or CTS/RTS

The benefits of using EZURiO Terminal are:

- Status of DSR, CTS, DCD and RI are continuously displayed
- DTR on the host PC can be directly controlled via a check box
- RTS can be directly controlled
- BREAK signals can be sent
- Scripts can be run to assist
- Additional built-in features speed development

EZURiO includes a "Data Transfer Test" mode allowing data to be sent as fast as the handshaking will permit. This feature is useful for testing the bit transfer rate of a Bluetooth connection.

The EZURiO terminal application is provided on the CD within this kit; updates are also available from our website: www.EZURiO.com

7. Interface Specification

7.1 Serial port connector

The pin-out for the 9 way D type connector is shown in the table below.

Note: The direction is as seen from the Module's perspective.

Pin	Description	Signal	Direction
1	Data Carrier Detect	DCD	Output
2	Transmit Data	TD	Output
3	Receive Data	RD	Input
4	Data Set Ready	DSR	Input
5	Ground	GND	---
6	Data Terminal Ready	DTR	Output
7	Clear To Send	CTS	Input
8	Request To Send	RTS	Output
9	Board Power or Ring Indicator	RI or Power	Output

7.2 Module Breakout connectors

All of the pins from the 40 way and 50 way connectors, WITH THE EXCEPTION OF Vcc are available on each of two rows of plated through holes on the long sides of the board. These translate directly to the pin layout of the module receptacles, allowing access to all of the module pins. Pin 1 is indicated by an ident on the silk screen.

The format of the holes allows the fitting of your choice of connectors, or they can be used for directly soldering test wires to the board. Both are laid out on a standard 0.1" (2.54mm) pitch.

7.3 PCM Interface

The Development board provides a dedicated audio interface for the Bluetooth modules. The pins provide the developer with access to the module's PCM lines as well as providing power to allow additional audio hardware to be developed. EZURiO has developed a range of audio codec interface boards that can be plugged directly onto this interface to support audio application development.

7.4 Board configuration jumpers

Jumper	Description
JP1	Breaks the supply to the module for current measurements
JP2	Selects external power supply for Siemens modules
JP8	Selects pin 9 power
J10	Selects low power mode for RS-232 level shifter

8. Other Features

8.1 Power Consumption Measurement

A removable jumper JP1 is provided to break the supply line directly to the modules, allowing the current consumption to be measured. For normal operation JP1 must be fitted.

Note that this only measures the current consumption of the module, and not of the level shifter or other peripheral circuitry.

8.1 USB Access

USB access can be provided to allow a direct USB connection to a Bluetooth HCI module. To do this remove resistors R17 and R18 from the development kit and replace them with zero Ohm links.

Note that if this is done and the unit is then connected to a USB host port, it will be powered from that same port. Do not attempt to use any other power source for the development kit when operating in this mode.

This is not relevant for modules with a UART interface.

9. Warranty

EZURiO warrants that its products shall conform to EZURiO's published specifications and remain free from defects in materials and workmanship under normal, proper and

intended use for a period of two (2) years from date of purchase, provided that proof of purchase be furnished with any returned equipment.

If during the warranty period any component part of the equipment becomes defective by reason of material or workmanship, and EZURiO is immediately notified of such defect, EZURiO shall at its option supply a replacement part or request return of equipment, freight prepaid, to its designated facility for repair. In the event no trouble is found on products returned for repair, EZURiO reserves the right to charge the customer its standard published repair charge.

This warranty shall not apply to any products that have been subject to misuse, bending, twisting, neglect, alteration, improper installation, testing or unauthorized repair performed by anyone other than an EZURiO designated repair facility. Any non-warranty repairs or maintenance shall be at EZURiO's standard rates in effect at the time.

This warranty is in lieu of all other warranties, whether expressed, implied, or statutory, including but not limited to, implied warranties or merchantability and fitness for a particular purpose. In no event shall EZURiO be liable, whether in contract, in part, or on any other basis, for any damage sustained by its customers or any other person arising from or related to loss of use, failure or interruption in the operation of any products, or delay in maintenance, or for incidental, consequential, in direct, or special damages or liabilities, or for loss of revenue, loss of business, or other financial loss arising out of or in connection with the sale, lease, maintenance, use, performance, failure, or interruption of these products.



EZURiO Ltd
Saturn House, Mercury Park
Wycombe Lane, Wooburn Green, HP10 0HH
United Kingdom
Tel: +44 1628 858 940
Fax: +44 1628 528 382

The information contained in this document is subject to change without notice. EZURiO Ltd makes no warranty of any kind with regard to this material including, but not limited to, the implied warranties of merchant ability and fitness for a particular purpose. EZURiO Ltd shall not be liable for errors contained herein or for incidental or consequential damages in connection with the furnishing, performance, or use of this material.

© Copyright 2007 EZURiO Limited. All rights reserved. No part of this document may be photocopied, reproduced, or translated to another language without the prior written consent of EZURiO.

www.ezurio.com

BLUETOOTH is a trademark owned by Bluetooth SIG, Inc., U.S.A. and licensed to EZURiO Ltd.

All other trademarks are the property of their respective owners.

The information contained within this Application Note is provided as a guide and is subject to change.